

**FLOOD CAPACITY MASTER PLAN  
FOR  
SYCAMORE CREEK**

Santa Barbara, California

November 21, 2003

CLIENT: Santa Barbara County Flood Control

PREPARED BY: Penfield & Smith  
101 East Victoria Street  
Santa Barbara, California 93101  
(805) 963-9532

WORK ORDER NO.: 14643.01

PROJECT MANAGER: Craig A. Steward, P.E.

PROJECT ENGINEER: Kelly R. Smith, P.E.

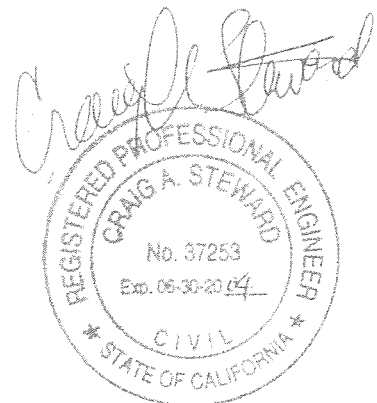

## PURPOSE OF REPORT

Sycamore Creek has areas of extensive flooding in recent years in the City of Santa Barbara (City). The capacity of the system is restricted due to bridge capacities and individual channel reach capacities.

The City and the Santa Barbara County Flood Control District (County) commissioned this study to evaluate the existing capacity of the creek system, and the capacity improvement potential of the system. This Master Plan will serve as a guide for future projects along the creek in terms of potential conveyance goals, not necessarily specific construction project configurations. The City and County desire to ultimately develop a long term project for improved flood control along Sycamore Creek. However, it is recognized that several other projects will materialize prior to the commencement of the long term project.

The City and County recognize that the feasibility of a long term project could be jeopardized by near term projects that, if not designed in a hydraulically coordinated manner, could threaten the ability of a capacity improvement project to ever be implemented.

Such a case presents itself at this time. The California Department of Transportation (Caltrans) is proposing various improvements to US 101, including replacement of the Sycamore Creek Bridge. This crossing, long recognized as one of many capacity restrictions, would set the capacity limits for the rest of the system. Since the bridge is over the most traveled highway in the County, it is recognized that any future replacement or modification for flood capacity would be impossible thus underscoring the need to develop a master plan for the creek system.

It is important that the Sycamore Creek Bridge on US 101 be constructed to the maximum feasible capacity. However, Caltrans expressed concerns that they did not want to build a bridge that would be in excess of any ultimate realistic system capacity.

Thus through this Flood Capacity Master Plan, based on analysis of realistic constraints, the feasible system capacity derived was 3,000 cubic feet per second (cfs). The 3,000 cfs target was arrived at using an iterative approach and considering economic, and physical constraints in the system.

With the development of the Master Plan, public and private projects could be coordinated to work towards the ultimate design capacity of 3,000 cfs. Future development projects, bridge replacements, and other projects of opportunity could be

pursued as they occur, thus making the ultimate goal of creek capacity improvement achievable. The plan encourages creek restoration and identifies locations of potential real estate acquisition by identification of specific capacity goals.

## LOCATION

Sycamore Creek originates in the Santa Ynez Mountains and flows through Santa Barbara to the Pacific Ocean. See Figure A. It has a drainage area of approximately 4 square miles. The focus of this study was the portion of the creek that flows from the Salinas, Alameda Padre Serra, Sycamore Canyon Road, and Yanonali Street roundabout to the Pacific Ocean.

## METHOD OF ANALYSIS

Penfield & Smith performed a topographic survey of critical cross sections of Sycamore Creek at the commencement of the study. Exhibits of the surveyed cross sections are included in the attached calculations<sup>1</sup>. The detailed cross section information was combined with City of Santa Barbara topographic mapping<sup>1</sup> to create a digital terrain model of the creek. HEC-GeoRAS<sup>2</sup> was used to create the input files to be used by HEC-River Analysis System<sup>3</sup> (HEC-RAS).

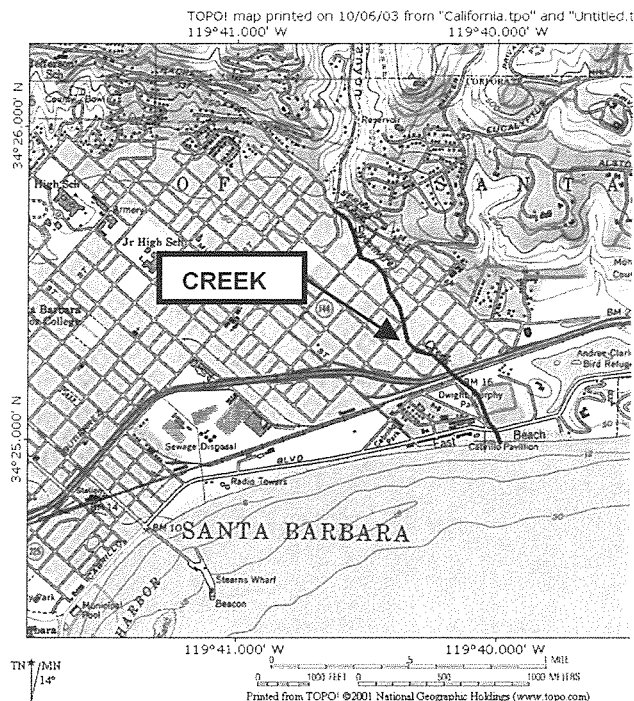

Figure A - Vicinity Map

<sup>1</sup> Penfield & Smith survey and the City of Santa Barbara topographic maps were prepared using the North American Vertical Datum.

<sup>2</sup> Hydrologic Engineering Center, U.S. Army Corps of Engineers; Geographical River Analysis System Computer Model, version 3.1.

<sup>3</sup> Hydrologic Engineering Center, U.S. Army Corps of Engineers; River Analysis System Computer Model, version 3.1.

A HEC-RAS analysis of the existing creek capacity was performed to establish present conditions. Profiles, cross sections and existing creek reach capacities are included in the attached calculations and described in the Results section.

Subsequent runs were executed to determine the creek improvements necessary to identify the upper limit of flows that could practically be conveyed throughout the Sycamore Creek system. By a succession of trial and error analyses that identified various bridge and creek capacity deficiencies, the target capacity was identified. The target capacity analysis profiles, cross sections, and results are included in the attached calculations. The creek improvements that were modeled were broken into projects that correspond to reaches of uniform creek section improvements and bridge replacements. These projects are detailed in the Results section below.

The projects are displayed as stylized channel improvements. However, they are intended to be used as a guideline for necessary conveyance. The roughness of the channel used in the analysis approximates natural or near-natural conditions. Community input and desires with respect to creek restoration, acquisition of available real estate, and costs will surely shape the direction and implementation of any final site specific projects.

## RESULTS

The initial capacity run results are shown in Table A. Profiles and cross sections generated by HEC-RAS for this model run are included in the attached calculations.

**TABLE A**

**SYCAMORE CREEK EXISTING CAPACITY RESULTS**

REACH #	REACH DESCRIPTION	RIVER STATION RANGE	EXISTING RUN Reach Capacity (cfs)
1	East Beach Pedestrian Bridge	0 to 344	3200
2	Cabrillo Blvd Bridge	344 to 465	3000
3	Between Cabrillo and Por La Mar Circle #1	604	3200
4	Por La Mar Circle Bridge #1	710 to 755	1800
5	Between Por La Mar Circle #1 and #2	932	1800
6	Por La Mar Circle Bridge #2	1110 to 1161	1500
7	Between Por La Mar Circle #2 and Zoo	1214	1600
8	Zoo Bridge	1270 to 1328	1100
9	Between Zoo and Railroad	1510	1300
10	Railroad Bridge	1652 to 1674	2400
11	101 Bridge	1723 to 1831	800
12	Between 101 and Punta Gorda Bridge	2051	1300
13	Punta Gorda Bridge	2144 to 2181	1400
14	Between Punta Gorda and Indio Muerto	2294 to 2529	2000
15	Indio Muerto Bridge	2729 to 2773	1200
16	Between Indio Muerto and Cacique Street	2805 to 3198	1200
17	Cacique Street Bridge	3277 to 3287	2500
18	Between Cacique and Carpinteria	3792 to 3837	3200
19	Carpinteria Bridge	3914 to 3953	2600
20	Between Carpinteria and Quinientos	4018 to 4322	2400
21	Quinientos Bridge	4440 to 4484	6000
22	Between Quinientos and Mason	4574 to 5021	5000
23	Mason Street Bridge	5112 to 5150	2500
24	Between Mason and Yanonali	5300 to 5535	2500
25	Yanonali Bridge	6139 to 6167	1400

By a series of creek and bridge refinements, taking into account available right of way and overtopping consequences, a maximum flow capacity of 3,000 cfs was determined to be practical, given the realistic constraints of the Sycamore Creek system. Short-term economic viability of any particular project or all the projects taken as a whole was not evaluated.

Table B summarizes the projects outlined in this analysis. The three separate Sycamore Creek Flood Capacity Master Plan Project Sheets included in this report

graphically and numerically illustrate the proposed projects. The profile and cross sections for this target capacity analysis are included in the attached calculations.

**TABLE B**

**SYCAMORE CREEK TARGET RUN PROJECT DESCRIPTIONS**

PROJECT	LOCATION DESCRIPTION	PROJECT DESCRIPTION
A	East Beach Pedestrian Bridge Downstream	Channel widened and channel bank slopes steepened
B	East Beach Pedestrian Bridge to Cabrillo Bridge Upstream	Channel widened and channel bank slopes steepened
C	Cabrillo Bridge Upstream to Por La Mar Circle Bridge #2	Channel widened and channel bank slopes steepened
D	Por La Mar Circle Bridge #1	Bridge replacement
E	Por La Mar Circle Bridge #2	Bridge replacement
F	Por La Mar Circle Bridge #2 Upstream to Zoo Bridge Downstream	Channel widened and channel bank slopes steepened
G	Zoo Culvert	Bridge replacement
H	Zoo Culvert Upstream to Railroad Bridge	Channel widened and channel bank slopes steepened
I	Railroad Bridge	Bridge replacement
J	Railroad Bridge Upstream to 101 Bridge Downstream	Channel widened and channel bank slopes steepened
K	101 Bridge	Bridge replacement
L	101 Bridge Upstream to Punta Gorda Bridge Downstream	Channel widened and channel bank slopes steepened. Levee added on right and left banks.
M	Punta Gorda Bridge	Bridge replacement. Floodwall added.
N	Punta Gorda Bridge Upstream to River station 2294	Channel widened and channel bank slopes steepened. Levee added on right and left banks.
O	Between River station 2294 to Indio Muerto Bridge Upstream	Channel widened and channel bank slopes steepened
P	Indio Muerto Bridge	Bridge replacement
Q	Between Indio Muerto and Cacique Bridge Upstream	Channel widened and channel bank slopes steepened
R	Between Cacique Bridge and Carpinteria Bridge Downstream	Channel widened and channel bank slopes steepened
S	Carpinteria Bridge Upstream to River station 4322	Channel widened and channel bank slopes steepened
T	Mason Street Bridge Downstream and Upstream	Channel widened and channel bank slopes steepened
U	Mason Street Bridge	Bridge replacement
V	Between Mason and River station 5300	Channel widened and channel bank slopes steepened. Levee added on left bank.
W	Between River station 5300 and Yanonali Downstream	Channel widened and channel bank slopes steepened
X	Yanonali Bridge	Bridge replacement

Each channel improvement project utilized a uniform creek section. Figure B shows the typical improved channel section used for each project. Figure C illustrates the typical bridge replacement section. Table C defines the value of each variable in the typical sections for each respective project.

**FIGURE B**  
**TYPICAL IMPROVED CREEK SECTION**

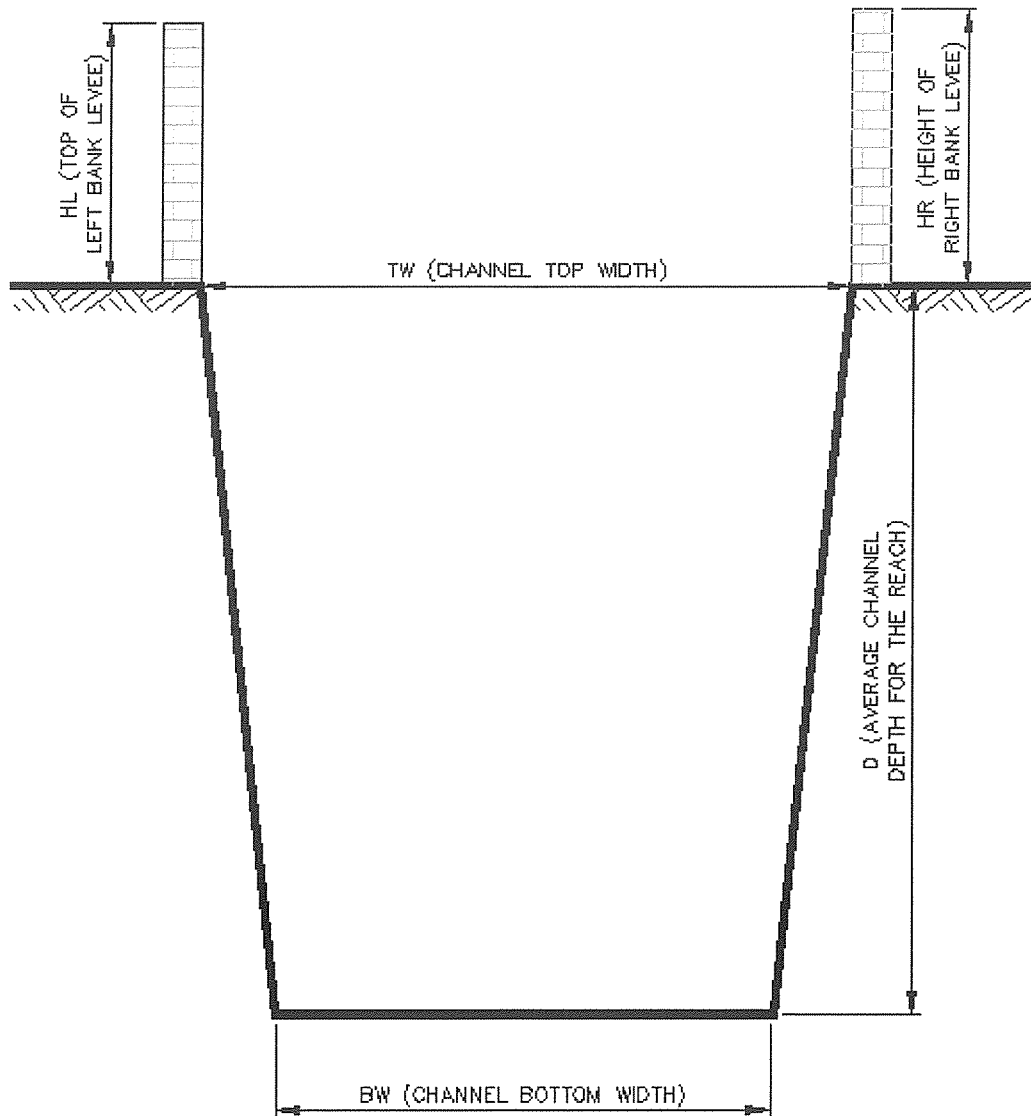

**FIGURE C**  
**TYPICAL BRIDGE REPLACEMENT SECTION**

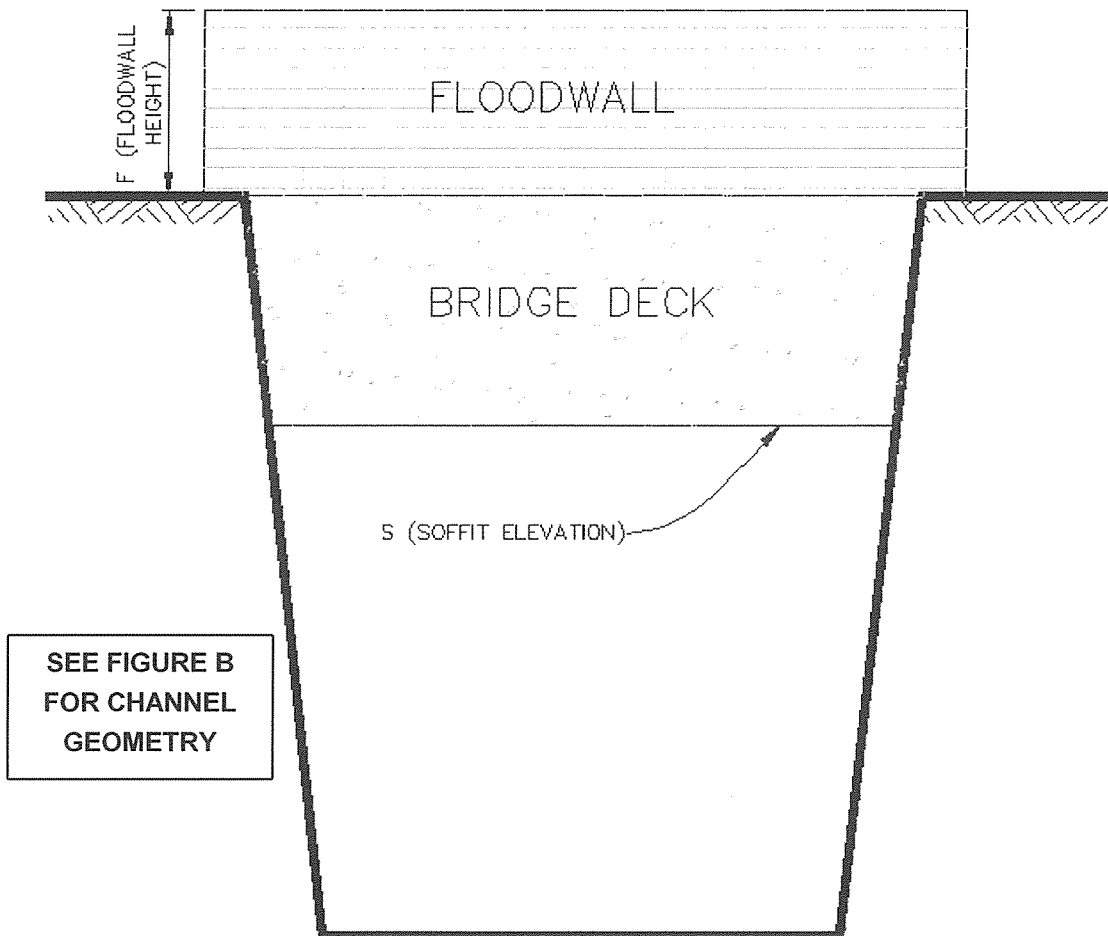

The brief project descriptions that follow summarize the parameters used in the HEC-RAS target run to successfully reach the 3,000 cfs target. Also refer to the three Sycamore Creek Flood Capacity Master Plan Project Sheets.

The following project descriptions describe the physical conditions at each location and denote "generic" improvements needed at each location. Actual projects in each reach will also include restoration components and possibly additional right-of-way acquisitions at each location.

**Project A**

Project A improves the channel downstream of the East Beach Pedestrian Bridge, from river station 0 to 344. The bottom width was increased to 45', top width to 60'. Average channel depth for the entire reach is 11'.



***Project B***

Project B improves the channel upstream of the East Beach Pedestrian Bridge to upstream of the Cabrillo Bridge, from river station 344 to 465. The bottom width was increased to 70', top width to 90'. Average channel depth for the entire reach is 11'.

***Project C***

Project C improves the channel upstream of the Cabrillo Bridge to Por La Mar Circle Bridge #2, from river station 465 to 1110. The bottom width was increased to 50', top width to 60'. Average channel depth for the entire reach is 11'.

***Project D***

Project D replaces Por La Mar Circle Bridge #1. This bridge is at river station 718. The replacement bridge was modeled as a deck with a soffit elevation of 11.3'. The bridge spans the creek without intermediate piers, and has an approximate flow area of 450 ft<sup>2</sup>.

***Project E***

Project E replaces Por La Mar Circle Bridge #2. This bridge is at river station 1123. The replacement bridge was modeled as a deck with a soffit elevation of 12.5'. The bridge spans the creek without intermediate piers, and has an approximate flow area of 400 ft<sup>2</sup>.

***Project F***

Project F improves the channel between Por La Mar Circle Bridge #2 and the Zoo Bridge, from river station 1161 to 1270. The bottom width was increased to 70', top width to 80'. Average channel depth for the entire reach is 10'.

***Project G***

Project G replaces Zoo Bridge. This bridge is at river station 1282. The replacement bridge was modeled as a deck with a soffit elevation of 13.4'. The bridge spans the creek without intermediate piers, and has an approximate flow area of 500 ft<sup>2</sup>.

***Project H***

Project H improves the channel between the Zoo Bridge and the Railroad Bridge, from river station 1328 to 1655. The bottom width was increased to 60', top width to 70'. Average channel depth for the entire reach is 10.3'.

***Project I***

Project I replaces Railroad Bridge. This bridge is at river station 1655. The replacement bridge was modeled as a deck with a soffit elevation of 15.8'. The bridge spans the creek without intermediate piers, and has an approximate flow area of 550 ft<sup>2</sup>.

***Project J***

Project J improves the channel between the Railroad Bridge and the 101 Bridge, from river station 1655 to 1730. The bottom width was increased to 80', top width to 90'. Average channel depth for the entire reach is 8.5'.

***Project K***

Project K replaces the 101 Bridge. This bridge is at river station 1730. The replacement bridge was modeled as a deck with a soffit elevation of 14.5'. The bridge spans the creek without intermediate piers, and has an approximate flow area of 550 ft<sup>2</sup>.

***Project L***

Project L improves the channel between the 101 Bridge and the Punta Gorda Bridge, from river station 1730 to 2151. The bottom width was increased to 40', top width to 40'. Average channel depth for the entire reach is 8.1'. Levees with a height of 1' will be required on both sides of the channel.

***Project M***

Project M replaces the Punta Gorda Bridge. This bridge is at river station 2151. The replacement bridge was modeled as a deck with a soffit elevation of 17'. The bridge spans the creek without intermediate piers, and has an approximate flow area of 400 ft<sup>2</sup>. A 1' floodwall to tie into the levees along the channel will be required.

***Project N***

Project N improves the channel upstream of the Punta Gorda Bridge, river station 2151, to river station 2294. The bottom width was increased to 60', top width to 60'. Average channel depth for the entire reach is 8.6'. Levees with a height of 1' will be required on both sides of the channel.

***Project O***

Project O improves the channel from river station 2294 to upstream of the Indio Muerto Bridge at river station 2773. The bottom width was increased to 35', top width to 35'. Average channel depth for the entire reach is 10.1'.

***Project P***

Project P replaces the Indio Muerto Bridge. This bridge is at river station 2732. The replacement bridge was modeled as a deck with a soffit elevation of 23'. The bridge spans the creek without intermediate piers, and has an approximate flow area of 300 ft<sup>2</sup>.

***Project Q***

Project Q improves the channel from upstream of the Indio Muerto Bridge to upstream of the Cacique Street Bridge, river station 2773 to 3287. The bottom width was increased to 40', top width to 45'. Average channel depth for the entire reach is 9.9'.

***Project R***

Project R improves the channel between the Cacique Street Bridge and the Carpinteria Bridge, river station 3287 to 3920. The bottom width was increased to 60', top width to 60'. Average channel depth for the entire reach is 13.8'.

***Project S***

Project S improves the channel between the Carpinteria Bridge, river station 3920, and river station 4322. The bottom width was increased to 50', top width to 50'. Average channel depth for the entire reach is 14'.

***Project T***

Project T improves the channel between downstream and upstream of the Mason Street Bridge, river station 5112 to 5150. The bottom width was increased to 60', top width to 80'. Average channel depth for the entire reach is 12.6'.

***Project U***

Project U replaces the Mason Street Bridge. This bridge is at river station 5123. The replacement bridge was modeled as a deck with a soffit elevation of 45'. The bridge spans the creek without intermediate piers, and has an approximate flow area of 600 ft<sup>2</sup>.

***Project V***

Project V improves the channel from upstream of the Mason Street Bridge, river station 5123, to river station 5300, river station 5112 to 5150. The bottom width was increased to 40', top width to 40'. Average channel depth for the entire reach is 7.4'. A 2' high levee will be required on the right side of the channel.

***Project W***

Project W improves the channel from river station 5123 to downstream of the Yanonali Bridge, river station 6139. The bottom width was increased to 40', top width to 50'. Average channel depth for the entire reach is 12.2'.

**Project X**

Project X replaces the Yanonali Street Bridge. This bridge is at river station 6141. The replacement bridge was modeled as a deck with a soffit elevation of 56'. The bridge spans the creek without intermediate piers, and has an approximate flow area of 400 ft<sup>2</sup>.

Table C is a summary of the parameters selected for the proposed projects.

**TABLE C**

**SYCAMORE CREEK TARGET RUN PROJECT PARAMETERS**

PROJECT	LOCATION DESCRIPTION	D	BW	TW	HR	HL	S	F
A	East Beach Pedestrian Bridge Downstream	11	45	60	0	0	NA	NA
B	East Beach Pedestrian Bridge to Cabrillo Bridge Upstream	11	70	90	0	0	NA	NA
C	Cabrillo Bridge Upstream to Por La Mar Circle Bridge #2	11	50	60	0	0	NA	NA
D	Por La Mar Circle Bridge #1	8.6	50	60	0	0	11.3	0
E	Por La Mar Circle Bridge #2	7.2	50	60	0	0	12.5	0
F	Por La Mar Circle Bridge #2 Upstream to Zoo Bridge Downstream	10	70	80	0	0	NA	NA
G	Zoo Culvert	6.8	70	80	0	0	13.4	0
H	Zoo Culvert Upstream to Railroad Bridge	10.3	60	70	0	0	NA	NA
I	Railroad Bridge	8.4	60	70	0	0	15.8	0
J	Railroad Bridge Upstream to 101 Bridge Downstream	8.5	80	90	0	0	NA	NA
K	101 Bridge	6.3	80	90	0	0	14.5	0
L	101 Bridge Upstream to Punta Gorda Bridge Downstream	8.1	40	40	1	1	NA	NA
M	Punta Gorda Bridge	6.3	60	60	0	0	17	1
N	Punta Gorda Bridge Upstream to River Station 2294	8.6	60	60	1	1	NA	NA
O	Between River Station 2294 to Indio Muerto Bridge Upstream	10.1	35	35	0	0	NA	NA
P	Indio Muerto Bridge	8.1	35	35	0	0	23	0
Q	Between Indio Muerto and Cacique Bridge Upstream	9.9	40	45	0	0	NA	NA
R	Between Cacique Bridge and Carpinteria Bridge Downstream	13.8	60	60	0	0	NA	NA
S	Carpinteria Bridge Upstream to River Station 4322	14	50	50	0	0	NA	NA
T	Mason Street Bridge Downstream and Upstream	12.6	60	80	0	0	NA	NA
U	Mason Street Bridge	9.2	60	80	0	0	45	0
V	Between Mason and River Station 5300	7.4	40	40	0	2	NA	NA
W	Between River Station 5300 and Yanonali Downstream	12.2	40	50	0	0	NA	NA
X	Yanonali Bridge	10	40	50	0	0	56	0

## **CONCLUSION**

The existing capacity of the analyzed section of Sycamore Creek falls below the Santa Barbara County Flood Control target of 3,000 cfs. A combination of extensive creek improvement and bridge replacement projects can increase the capacity of the creek to 3,000 cfs.

## **CALCULATIONS AND ATTACHMENTS**

**Surveyed Cross Sections  
For Sycamore Creek Master Plan**

**LEGEND**

SPOT ELEVATION, DESCRIPTION  
POINT #

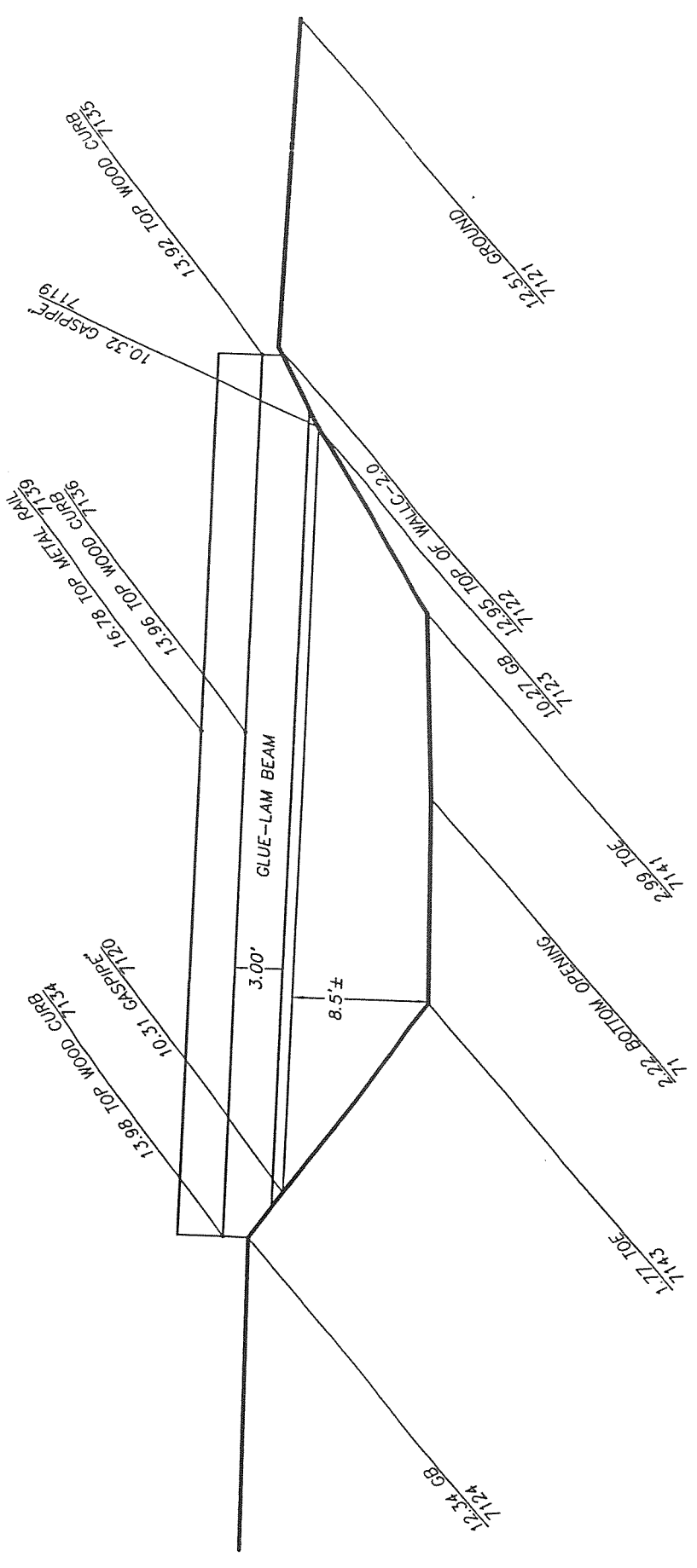

**SYCAMORE CREEK  
RIVER STATION 344  
LOOKING DOWNSTREAM  
EAST BEACH PEDESTRIAN BRIDGE**

**Penfield & Smith**  
ENGINEERS • SURVEYORS • PLANNERS

14643.01 14643T1-BRG.DWG

1" = 10'



**LEGEND**

SPOT ELEVATION, DESCRIPTION  
POINT #

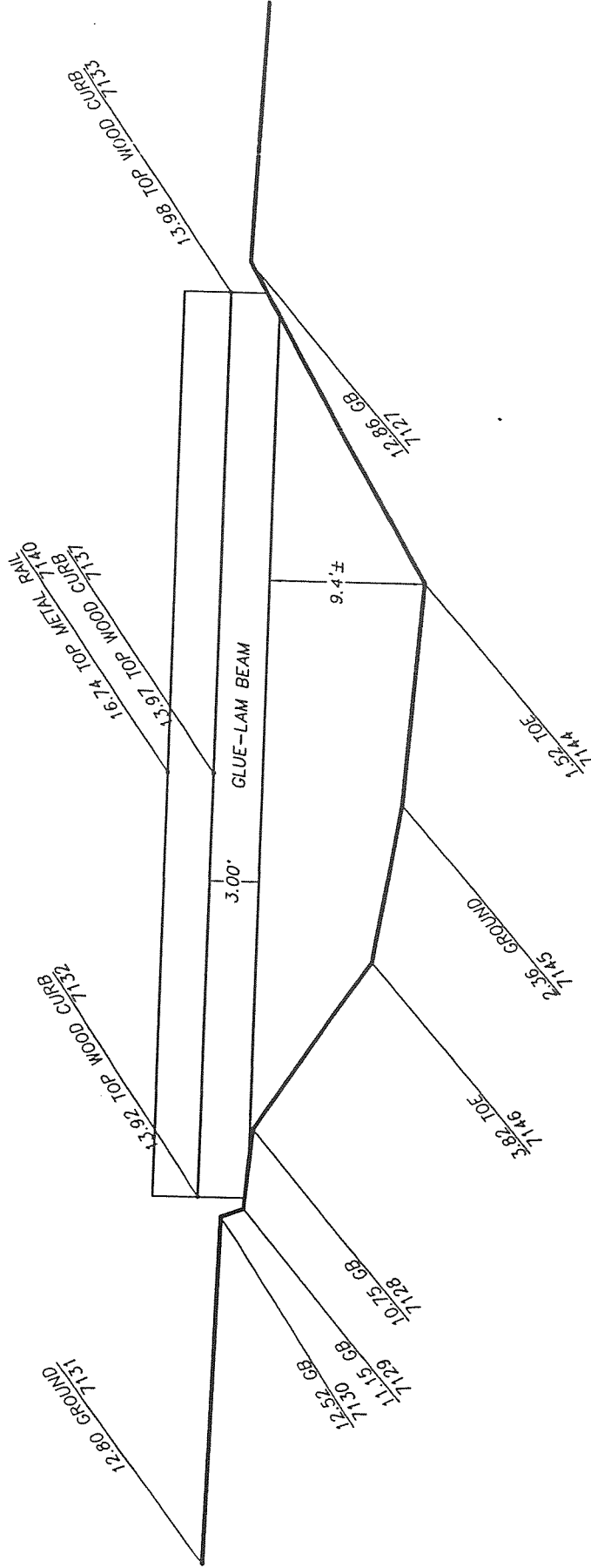

**SYCAMORE CREEK  
RIVER STATION 334  
LOOKING UPSTREAM  
EAST BEACH PEDESTRIAN BRIDGE**

**Penfield & Smith**  
ENGINEERS • SURVEYORS • PLANNERS

14643.01 14643T1-BRG.DWG

1" = 10'

**SYCAMORE CREEK  
RIVER STATION 359  
LOOKING UPSTREAM**  
CABRILLO BLVD. BRIDGE

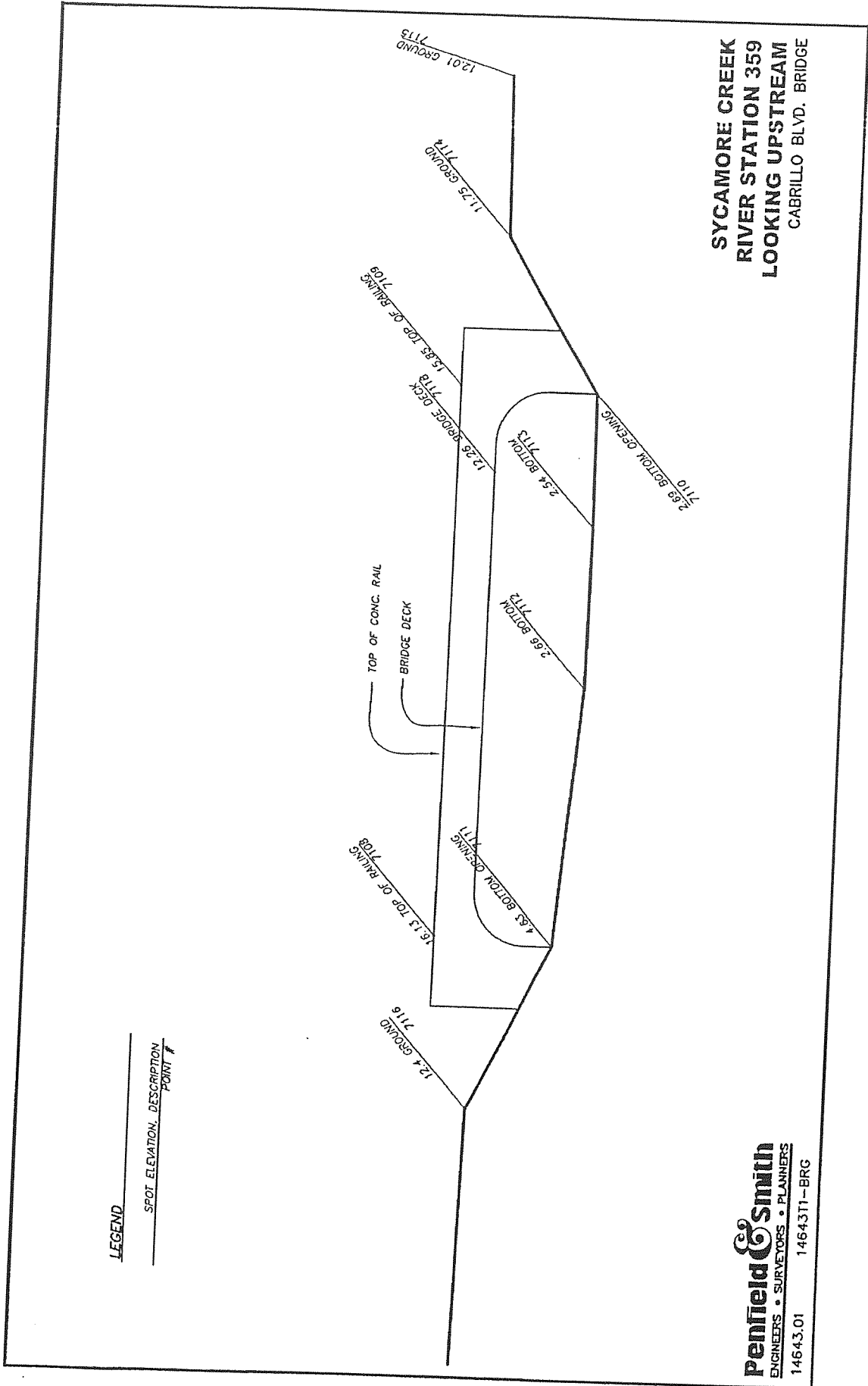

**LEGEND**

SPOT ELEVATION, DESCRIPTION  
POINT #

**Pentfield & Smith**  
ENGINEERS • SURVEYORS • PLANNERS  
14643.01 14643T1 - BRG

SYCAMORE CREEK  
 RIVER STATION 465  
 LOOKING DOWNSTREAM  
 CABRILLO BLVD. BRIDGE

LEGEND

SPOT ELEVATION DESCRIPTION  
 POINT #

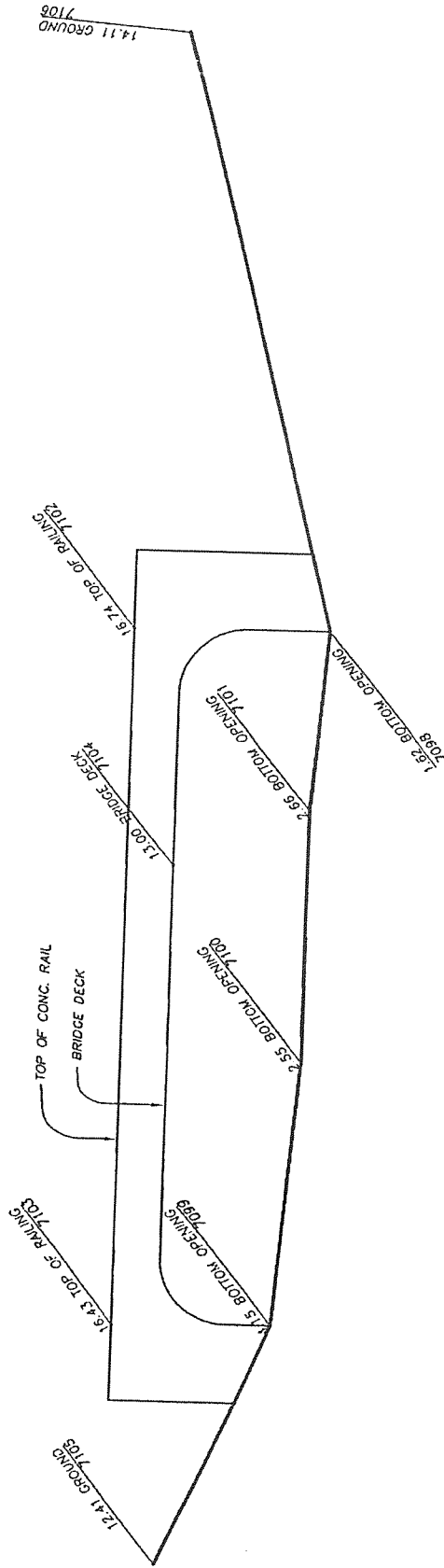

**LEGEND**

17.02 SPOT ELEVATION+ DESC  
7239 SURVEY POINT #

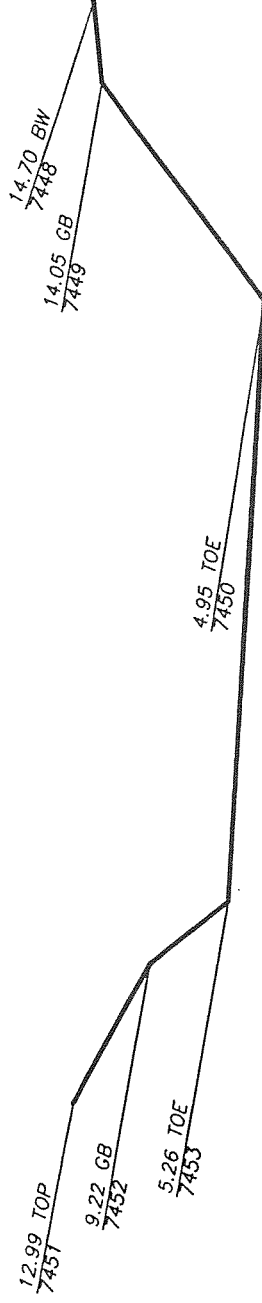

**SYCAMORE CREEK  
RIVER STATION 604  
LOOKING DOWNSTREAM  
NEAR DEL PARQUE DRIVE**

**Penfield & Smith**  
ENGINEERS • SURVEYORS • PLANNERS

14643.01

14643T1

1" = 10'

**SYCAMORE CREEK**  
**RIVER STATION 710**  
**LOOKING UPSTREAM**  
 POR LA MAR CIRCLE BRIDGE #1

**LEGEND**

SPOT ELEVATION, DESCRIPTION  
 POINT #

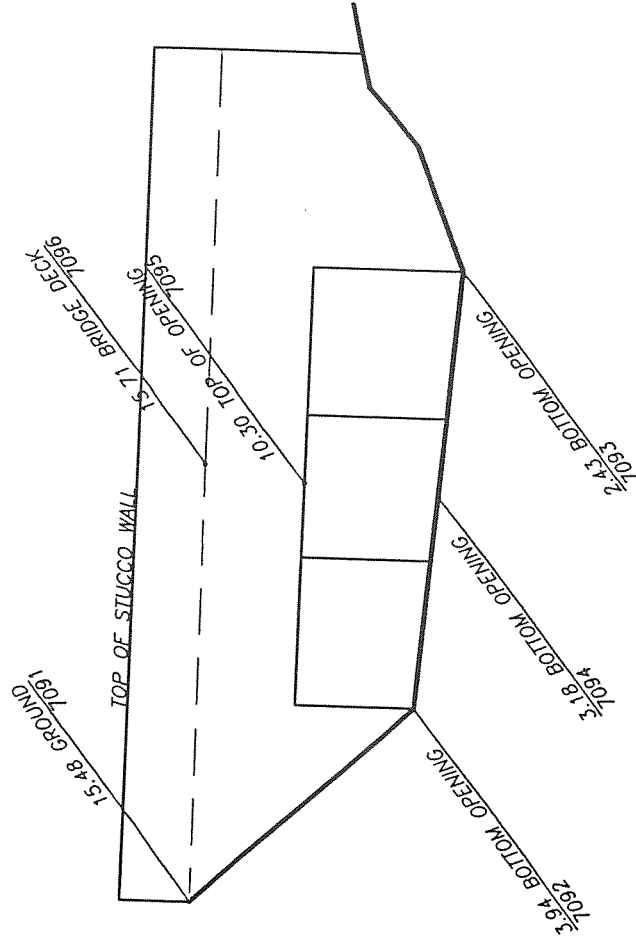

**Penfield & Smith**  
 ENGINEERS • SURVEYORS • PLANNERS

14643T1 - BRG.DWG

14643.01

1" = 10'

LEGEND

SPOT ELEVATION, DESCRIPTION  
POINT #

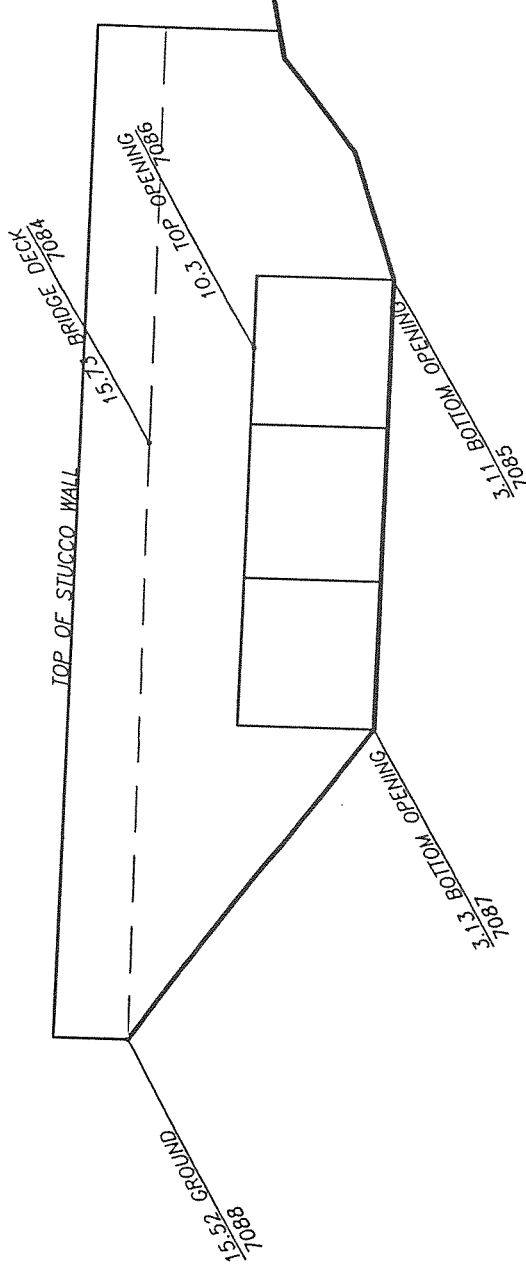

**SYCAMORE CREEK  
RIVER STATION 755  
LOOKING DOWNSTREAM  
FOR LA MAR CIRCLE BRIDGE #1**

**Penfield & Smith**  
ENGINEERS • SURVEYORS • PLANNERS

14643T1 - BRG.DWG

1" = 10'

14643.01

**LEGEND**

17.02 SPOT ELEVATION± DESC+  
7239 ○  
SURVEY POINT #

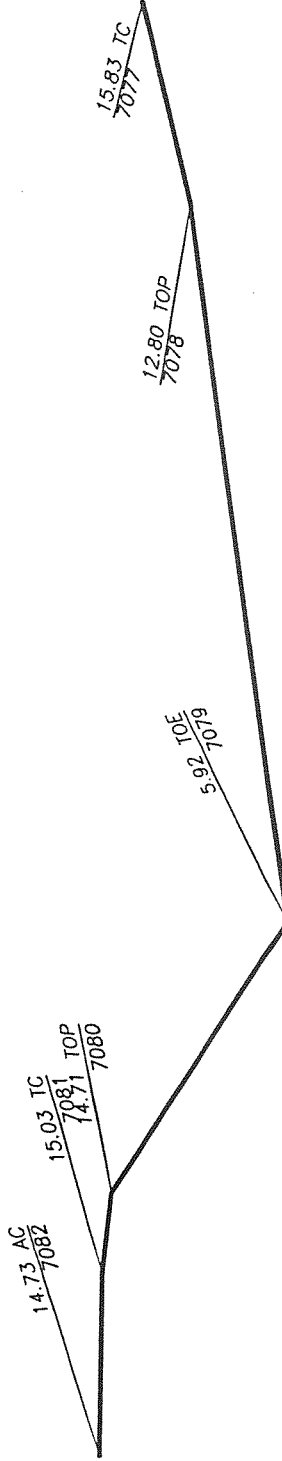

**SYCAMORE CREEK  
RIVER STATION 932  
LOOKING DOWNSTREAM  
NEAR POR LA MAR CIRCLE**

**Penfield & Smith**  
ENGINEERS • SURVEYORS • PLANNERS

14643.01 14643T1

1" = 10'

**LEGEND**

SPOT ELEVATION, DESCRIPTION  
POINT #

BW BACK OF WALKWAY

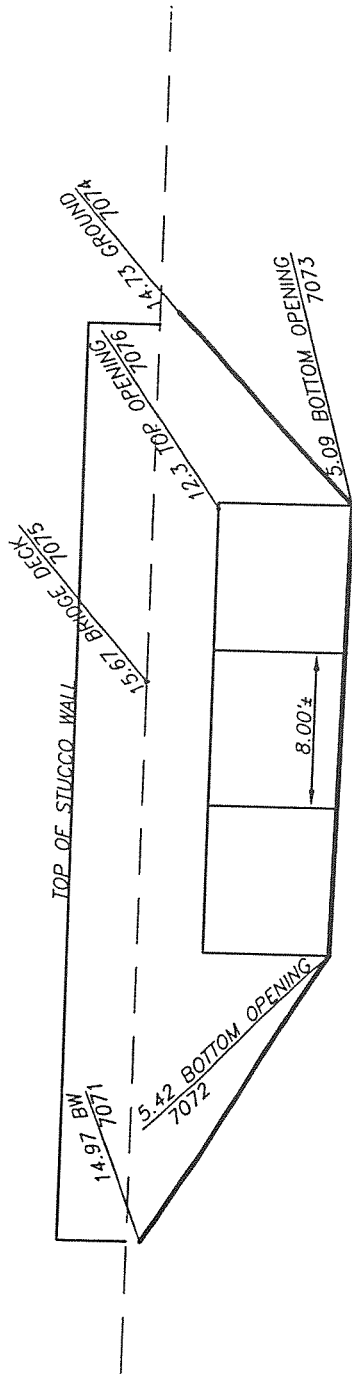

**SYCAMORE CREEK  
RIVER STATION 1110  
LOOKING UPSTREAM  
FOR LA MAR CIRCLE BRIDGE #2**

**Penfield & Smith**  
ENGINEERS • SURVEYORS • PLANNERS  
14643.01 14643T1-BRG

1" = 10'



**LEGEND**

SPOT ELEVATION, DESCRIPTION  
POINT #

BW BACK OF WALKWAY

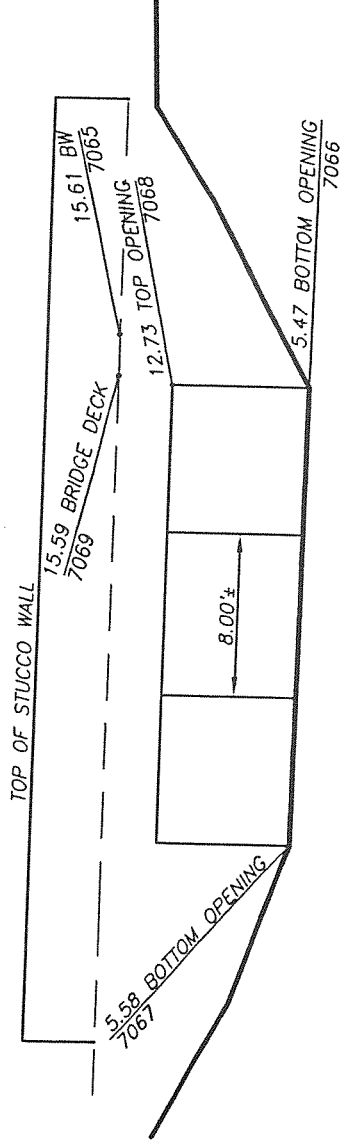

**SYCAMORE CREEK  
RIVER STATION 1161  
LOOKING DOWNSTREAM  
FOR LA MAR CIRCLE BRIDGE #2**

**Penfield & Smith**  
ENGINEERS • SURVEYORS • PLANNERS

14643.01 14643T1-BRG

1" = 10'

**LEGEND**

17.02  
7239 —○— SPOI ELEVATION+ DESC.  
SURVEY POINT #



**SYCAMORE CREEK  
RIVER STATION 1214  
LOOKING DOWNSTREAM  
BETWEEN EL ESCORIAL AND ZOO**

**Penfield & Smith**  
ENGINEERS • SURVEYORS • PLANNERS

14643.01 14643T1

1" = 10'

**SYCAMORE CREEK  
RIVER STATION 1270  
LOOKING UPSTREAM**

**LEGEND**

SPOT ELEVATION, DESCRIPTION  
POINT #

BW BACK OF WALKWAY

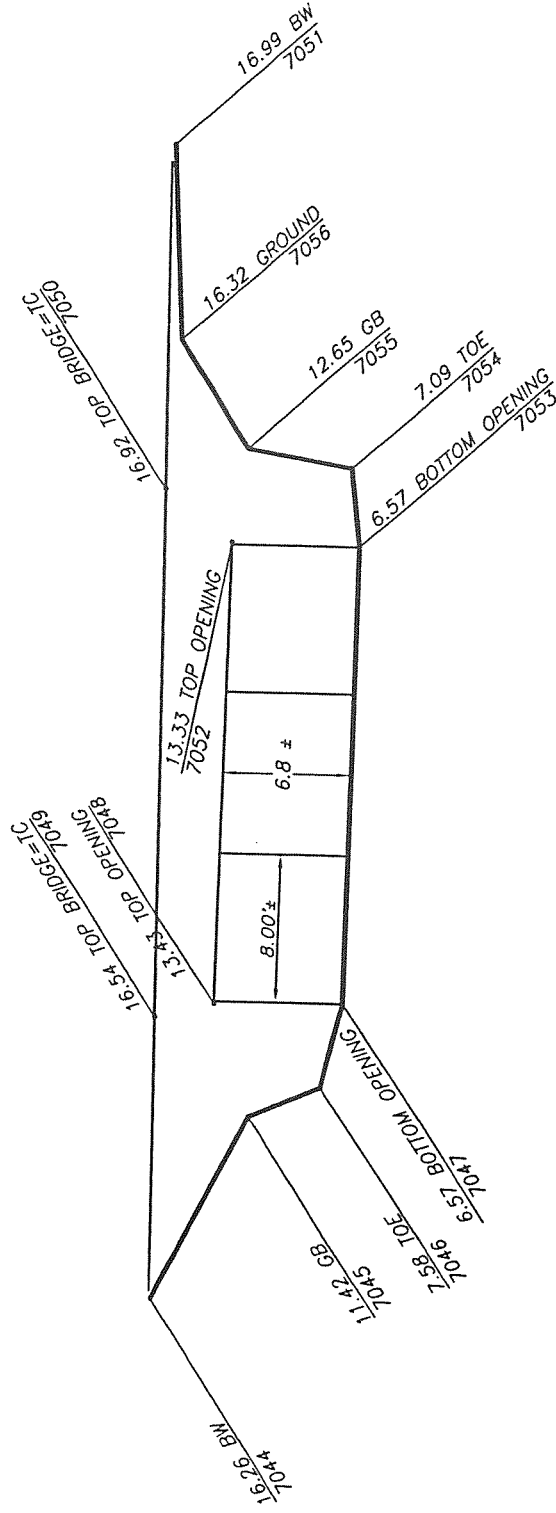

**Penfield & Smith**  
ENGINEERS • SURVEYORS • PLANNERS

14643.01 14643T1-BRG.DWG

1" = 10'

**LEGEND**

SPOT ELEVATION, DESCRIPTION  
POINT #

BW BACK OF WALKWAY

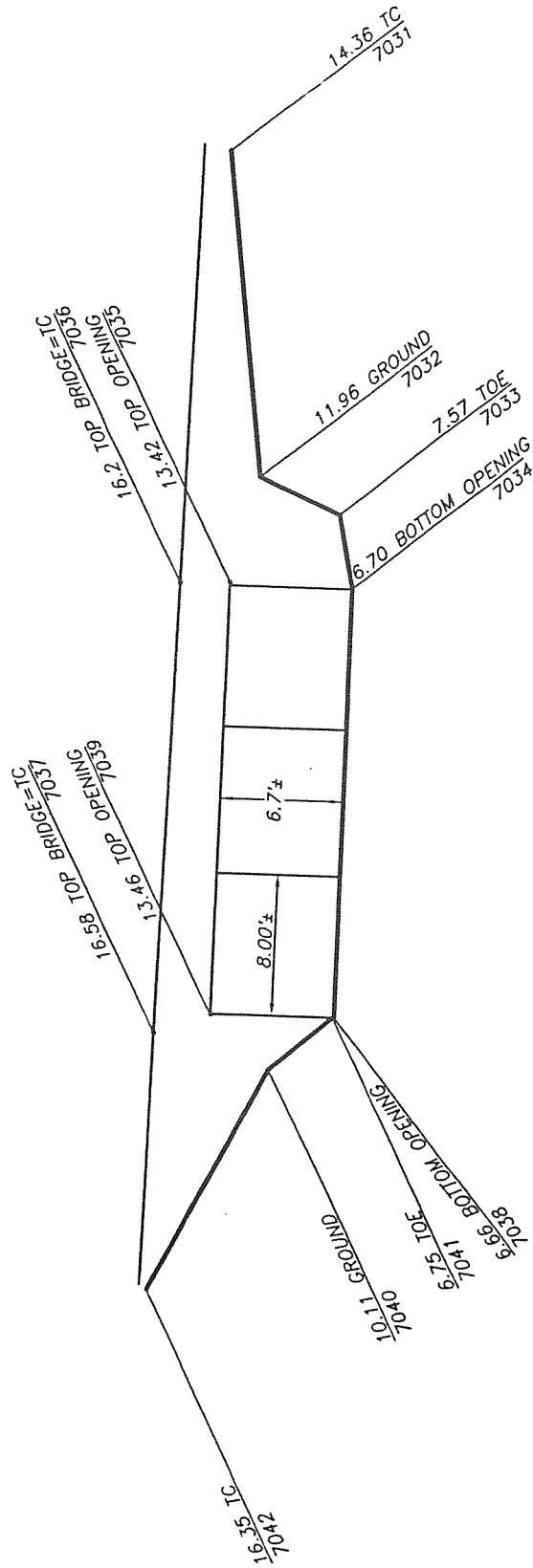

**SYCAMORE CREEK  
RIVER STATION 1328  
LOOKING DOWNSTREAM**

**Penfield & Smith**  
ENGINEERS • SURVEYORS • PLANNERS

14643.01 14643T1 - BRG.DWG

1" = 10'

**LEGEND**

17.02  
7239 ——— SPOT ELEVATION+ DESC  
SURVEY POINT #

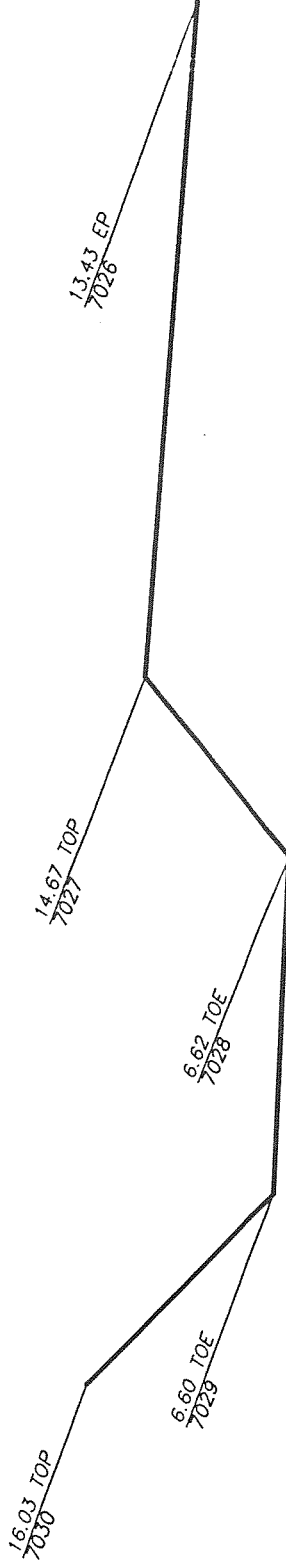

**SYCAMORE CREEK  
RIVER STATION 1510  
LOOKING DOWNSTREAM  
BETWEEN ZOO AND RAILROAD**

**Penfield & Smith**  
ENGINEERS • SURVEYORS • PLANNERS

14643.01

14643T1

1" = 10'

**LEGEND**

SPOT ELEVATION, DESCRIPTION  
POINT #

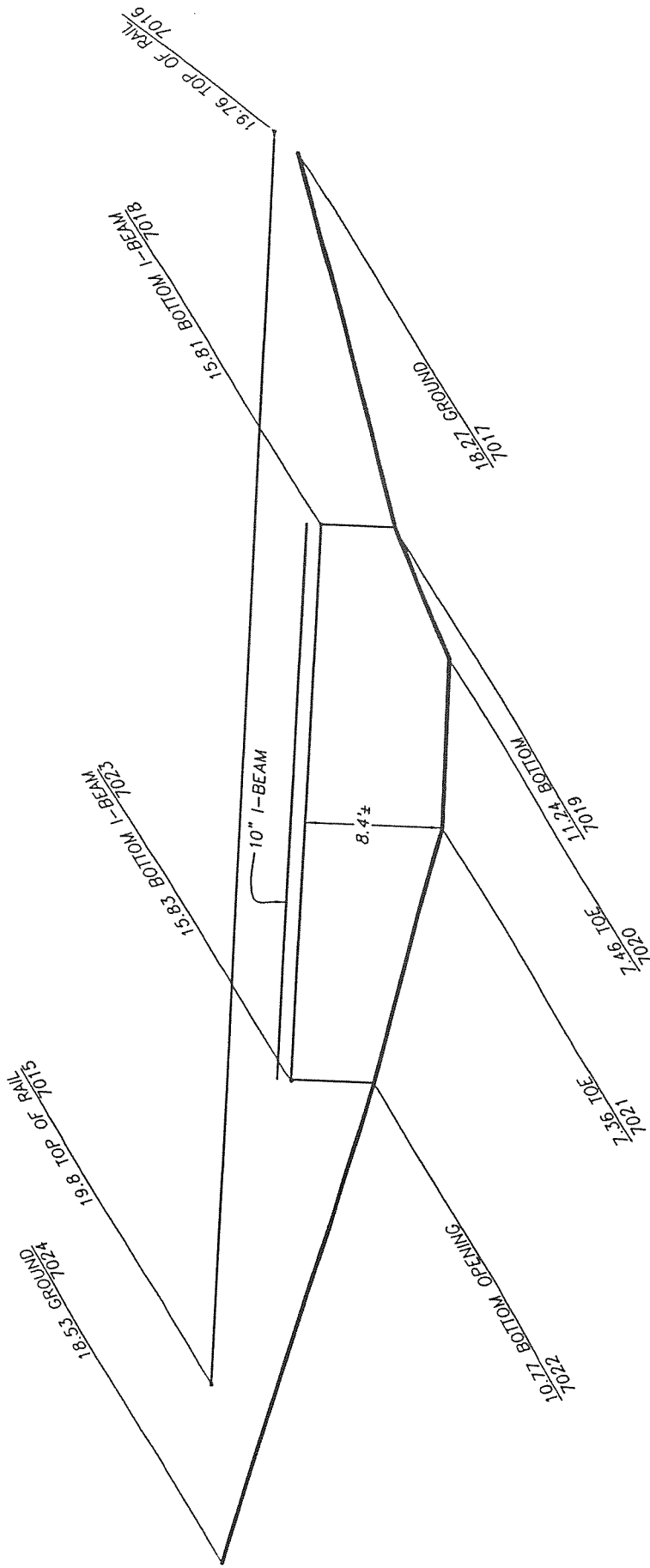

**SYCAMORE CREEK  
RIVER STATION 1652  
LOOKING UPSTREAM  
RAILROAD BRIDGE**

**Penfield & Smith**  
ENGINEERS • SURVEYORS • PLANNERS  
14643.01 14643T01-BRG.DWG 1" = 10'

**LEGEND**

SPOT ELEVATION, DESCRIPTION  
POINT #

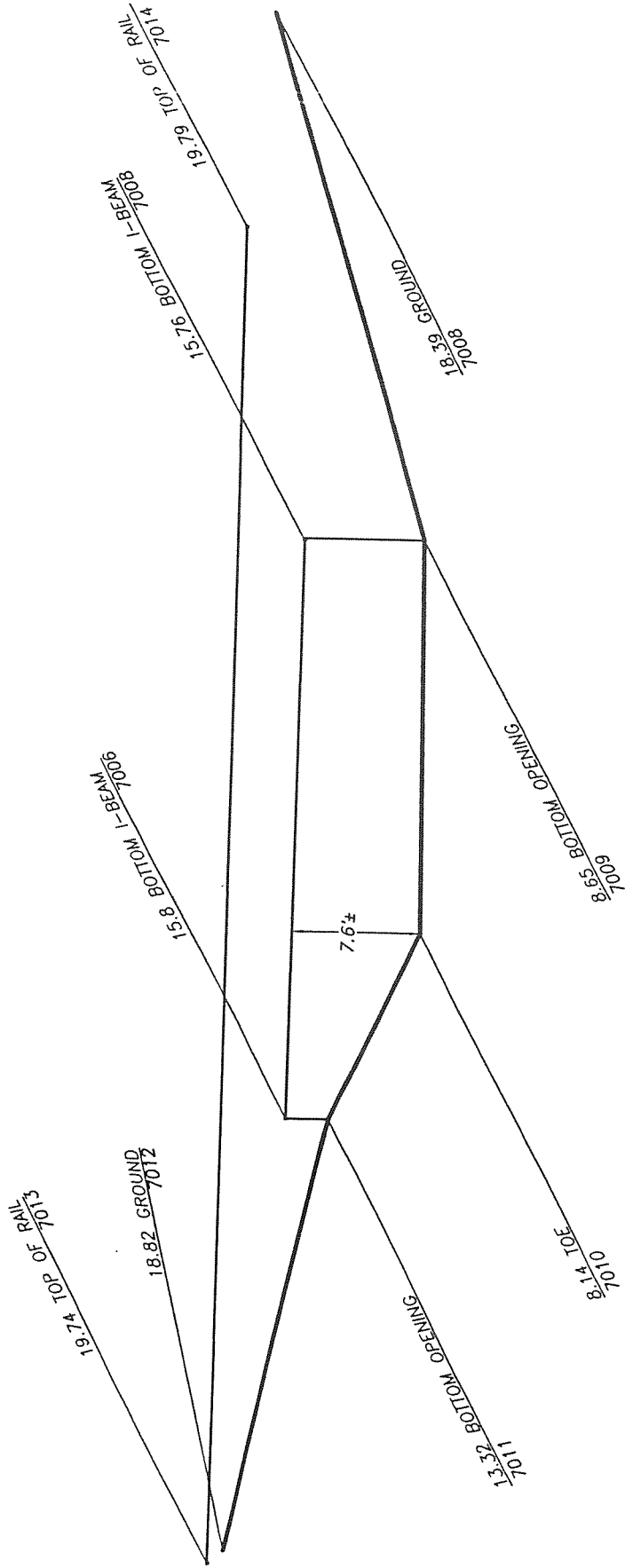

**SYCAMORE CREEK  
RIVER STATION 1674  
LOOKING DOWNSTREAM  
RAILROAD BRIDGE**

**Penfield & Smith**  
ENGINEERS • SURVEYORS • PLANNERS

14643.01

14643T01-BRG.DWG

1" = 10'

**LEGEND**

SPOT ELEVATION, DESCRIPTION  
POINT #

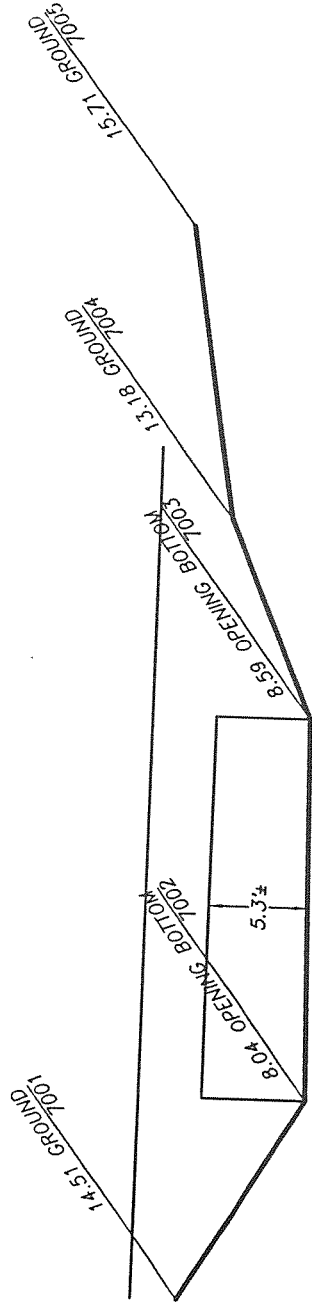

**SYCAMORE CREEK  
RIVER STATION 1723  
LOOKING UPSTREAM  
101 BRIDGE**

**Penfield & Smith**  
ENGINEERS • SURVEYORS • PLANNERS

14643.01

14643T01 - BRG.DWG

1" = 10'



**LEGEND**

SPOT ELEVATION, DESCRIPTION  
POINT #

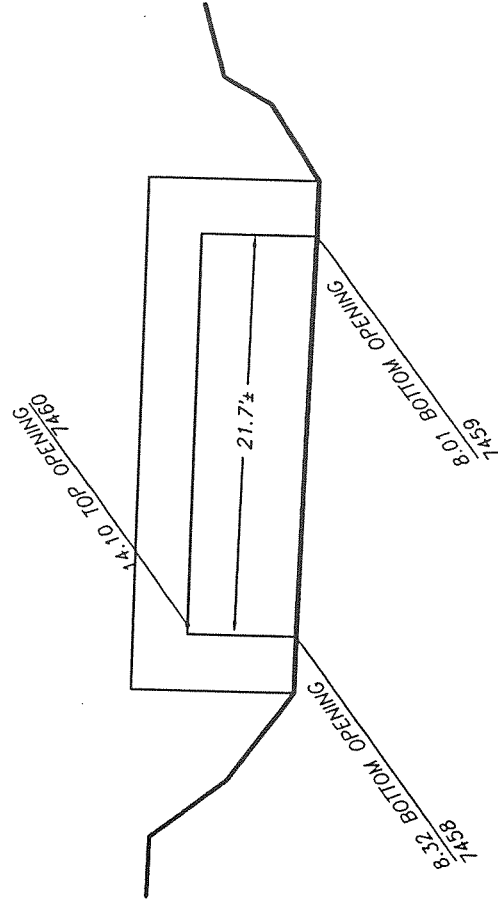

**SYCAMORE CREEK  
RIVER STATION 1831  
LOOKING DOWNSTREAM  
101 BRIDGE**

**Penfield & Smith**  
ENGINEERS • SURVEYORS • PLANNERS

14643.01 14643T01-BRG.DWG

1" = 10'

**LEGEND**

17.02  
7239 —○— SPOT ELEVATION+ DESC.  
SURVEY POINT #

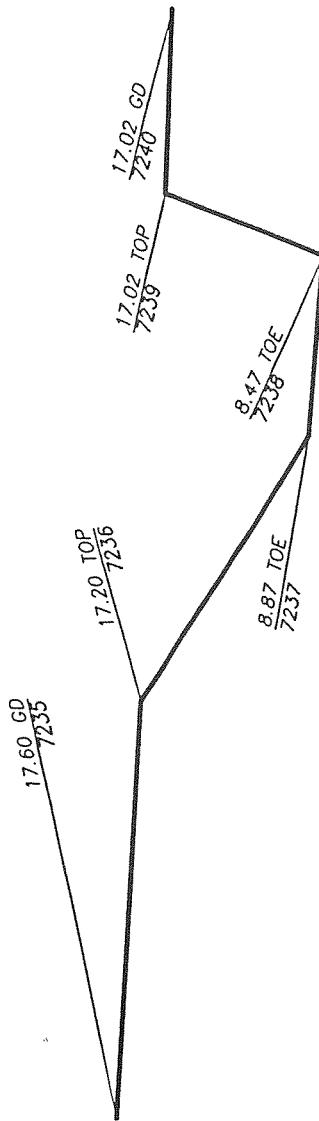

**SYCAMORE CREEK  
RIVER STATION 2051  
LOOKING DOWNSTREAM  
BETWEEN 101 AND PUNTA GORDA**

**Penfield & Smith**  
ENGINEERS • SURVEYORS • PLANNERS

14643.01

14643T1

1" = 10'

**LEGEND**

SPOT ELEVATION, DESCRIPTION  
POINT #

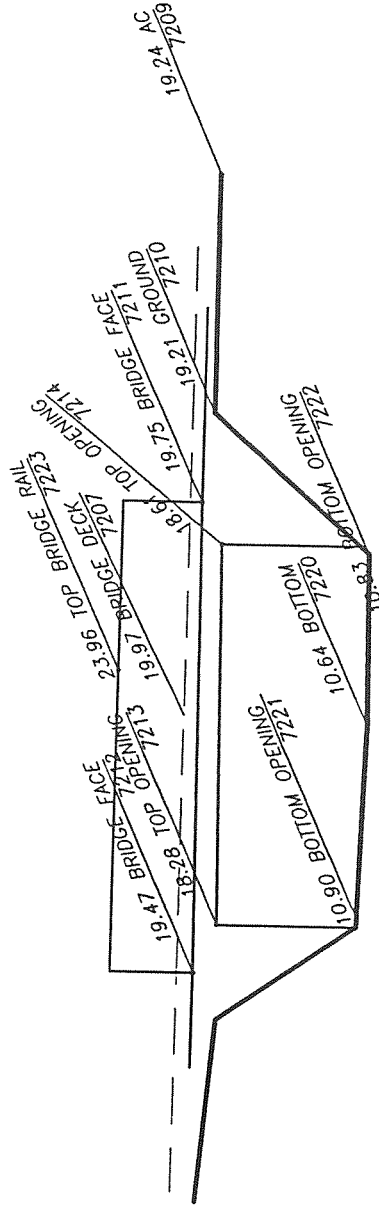

**SYCAMORE CREEK  
RIVER STATION 2144  
LOOKING UPSTREAM  
PUNTA GORDA**

**Penfield & Smith**  
ENGINEERS • SURVEYORS • PLANNERS

14643.01 14643T01-BRG.DWG 1" = 10'

**LEGEND**

SPOT ELEVATION, DESCRIPTION  
POINT #

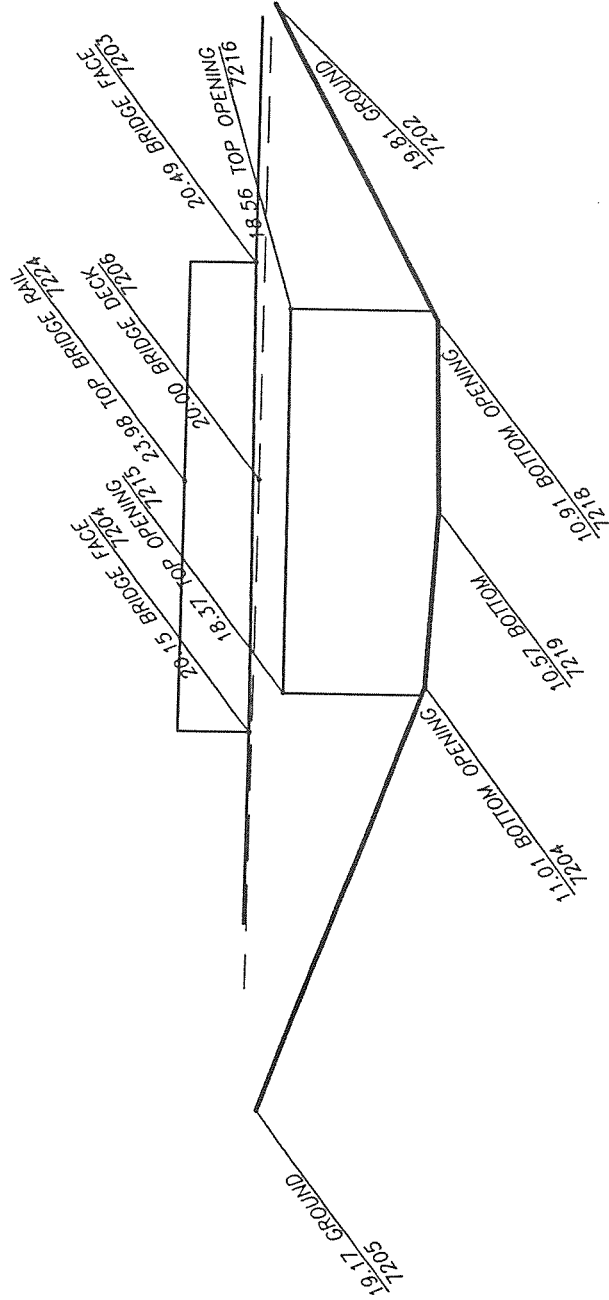

**SYCAMORE CREEK  
RIVER STATION 2181  
LOOKING DOWNSTREAM  
PUNTA GORDA**

**Penfield & Smith**  
ENGINEERS • SURVEYORS • PLANNERS

14643.01 14643T01-BRG.DWG 1" = 10'

**LEGEND**

17.02  
7239

---

SPOT ELEVATION+ DESC  
SURVEY POINT #

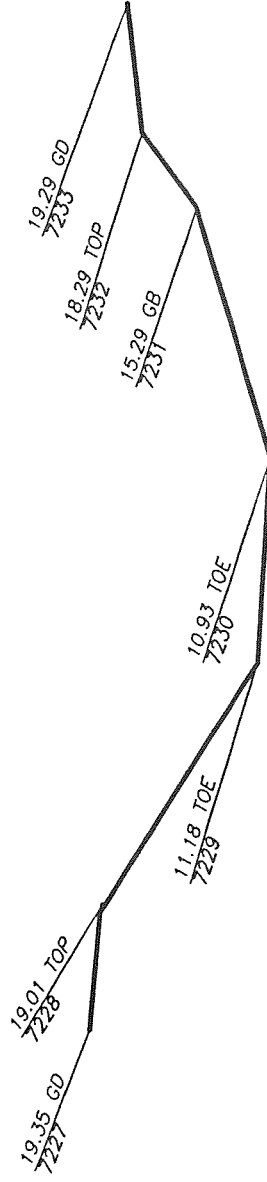

**SYCAMORE CREEK  
RIVER STATION 2294  
LOOKING DOWNSTREAM  
BETWEEN PUNTA GORDA AND LIBERTY**

**Penfield & Smith**  
ENGINEERS • SURVEYORS • PLANNERS

14643.01 14643T1

1" = 10'

**LEGEND**

SPOT ELEVATION, DESCRIPTION  
POINT #

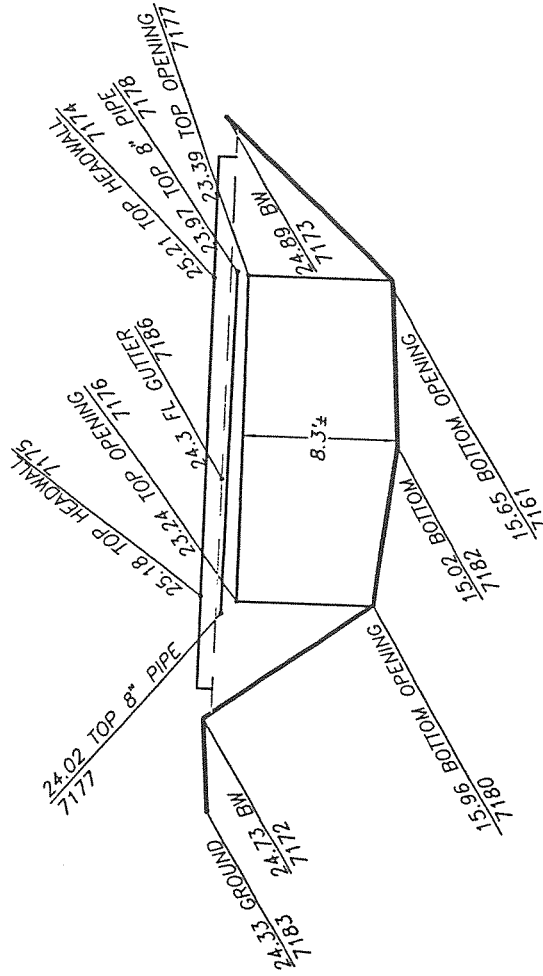

**SYCAMORE CREEK  
RIVER STATION 2773  
LOOKING DOWNSTREAM  
INDO MUERTO BRIDGE**

**Penfield & Smith**  
ENGINEERS • SURVEYORS • PLANNERS

14643.01 14643T01-BRG.DWG

1" = 10'

**LEGEND**

17.02 SPOT\_ELEVATION+ DESC  
7239 SURVEY POINT #

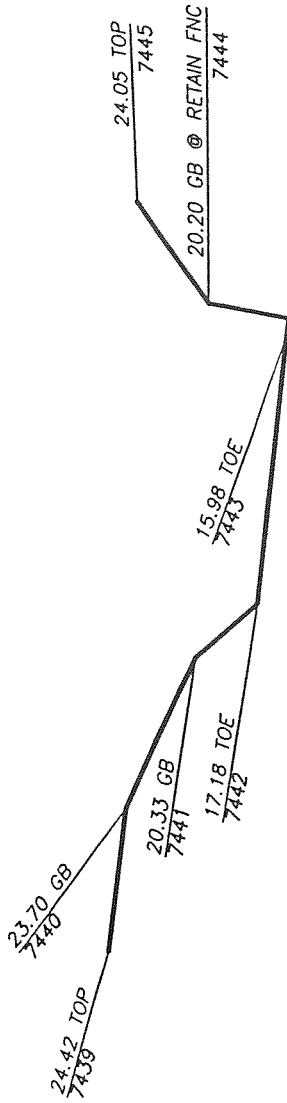

**SYCAMORE CREEK  
RIVER STATION 2805  
LOOKING DOWNSTREAM  
UPSTREAM OF INDIO MUERTO**

**Penfield & Smith**  
ENGINEERS • SURVEYORS • PLANNERS

14643.01 14643T1

1" = 10'

**SYCAMORE CREEK  
RIVER STATION 2529  
LOOKING DOWNSTREAM  
NEAR LIBERTY STREET**

**LEGEND**

- 17.02 SPOT ELEVATION+ DESC  
7239 SURVEY POINT #
- GUT = GUTTER
- TCC = TOP OF CONCRETE CHANNEL

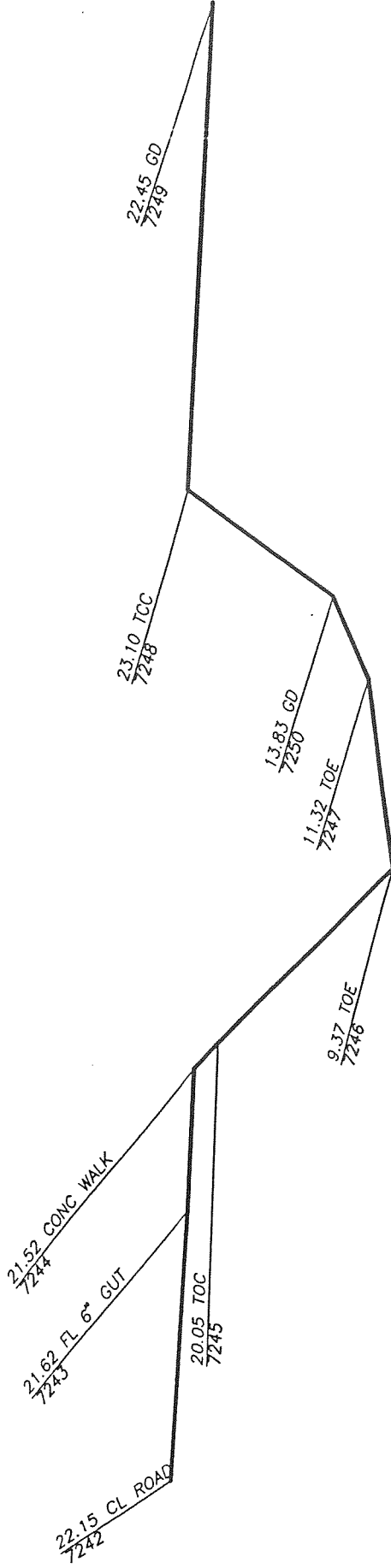

**Penfield & Smith**  
ENGINEERS • SURVEYORS • PLANNERS

14643.01

14643T1

1" = 10'



**LEGEND**

17.02  
7239 —○— SPOT ELEVATION+ DESC  
SURVEY POINT #

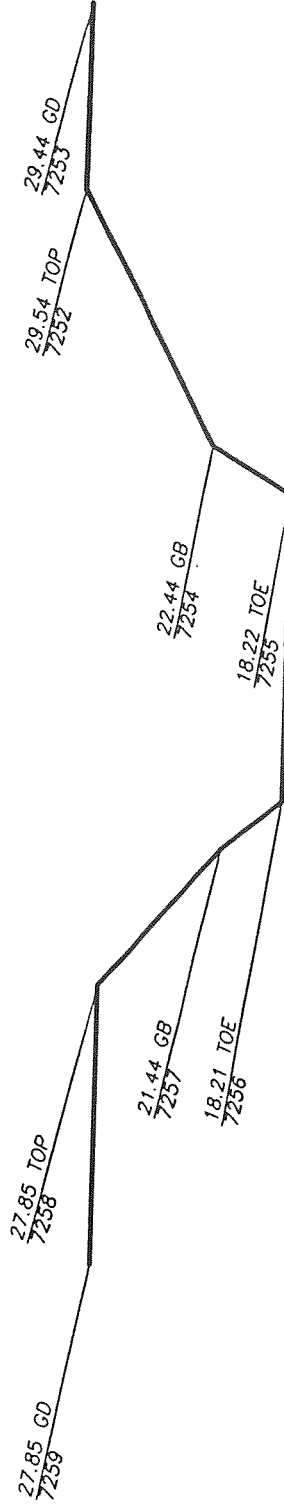

**SYCAMORE CREEK**  
**RIVER STATION 3198**  
**LOOKING DOWNSTREAM**  
DOWNSTREAM OF CACIQUE

**Penfield & Smith**  
ENGINEERS • SURVEYORS • PLANNERS

14643.01 14643T1

1" = 10'

**LEGEND**

SPOT ELEVATION, DESCRIPTION  
POINT #

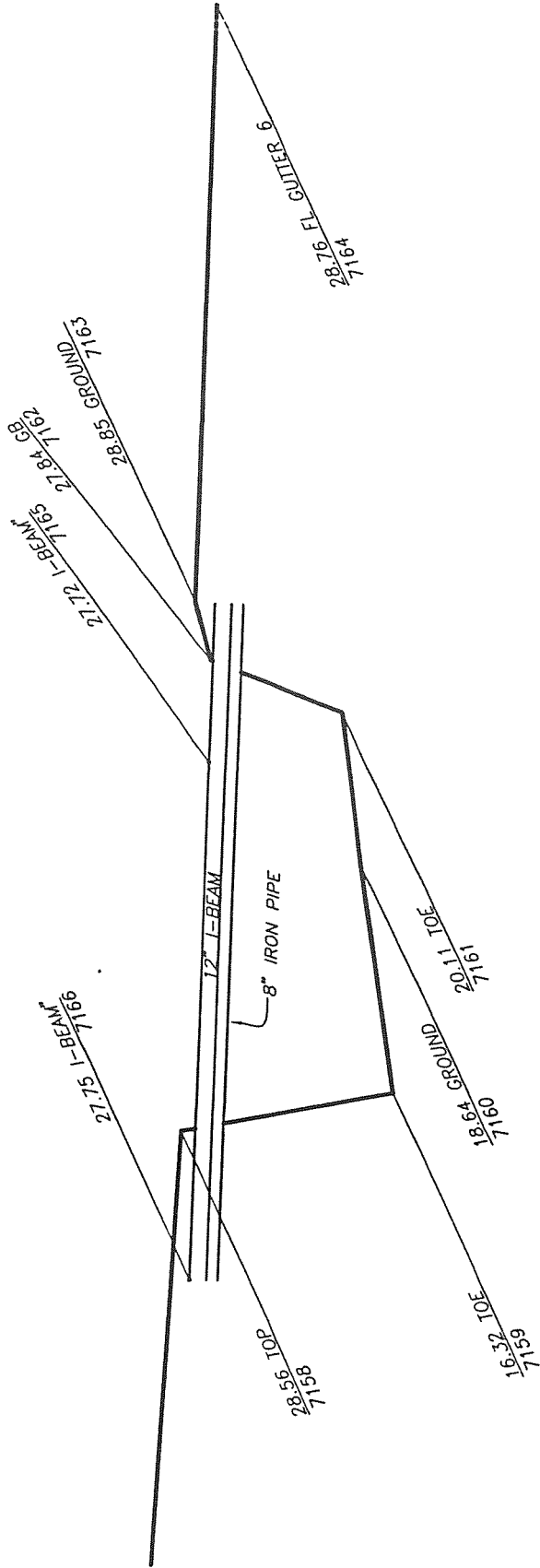

**SYCAMORE CREEK  
RIVER STATION 3277  
LOOKING UPSTREAM**  
NEAR CACIQUE PEDESTRIAN BRIDGE

**Penfield & Smith**  
ENGINEERS • SURVEYORS • PLANNERS

14643.01

14643T01-BRG.DWG

1" = 10'

**LEGEND**

SPOT ELEVATION, DESCRIPTION  
POINT #

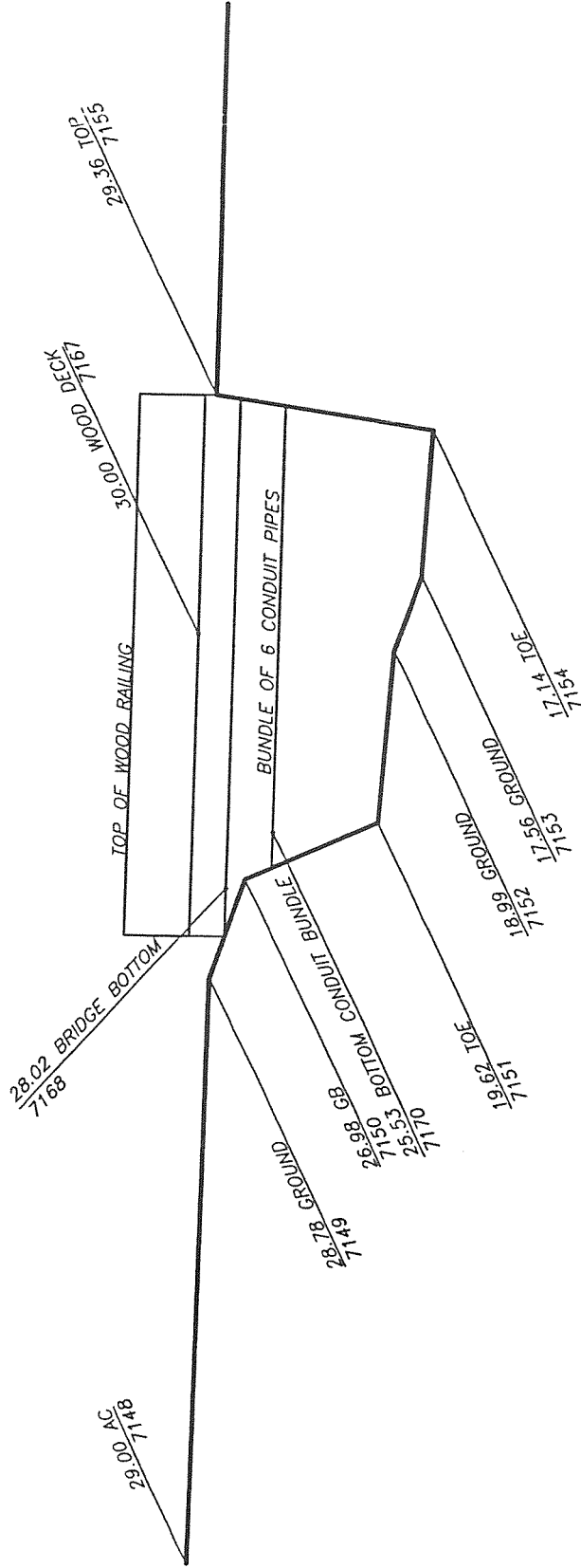

**SYCAMORE CREEK  
RIVER STATION 3287  
LOOKING DOWNSTREAM  
CACIQUE PEDESTRIAN BRIDGE**

**Penfield & Smith**  
ENGINEERS • SURVEYORS • PLANNERS

14643.01 14643T01 - BRG.DWG

1" = 10'

# LEGEND

17.02  
7239 ———— ○ SPOT ELEVATION+ DESC  
SURVEY POINT #

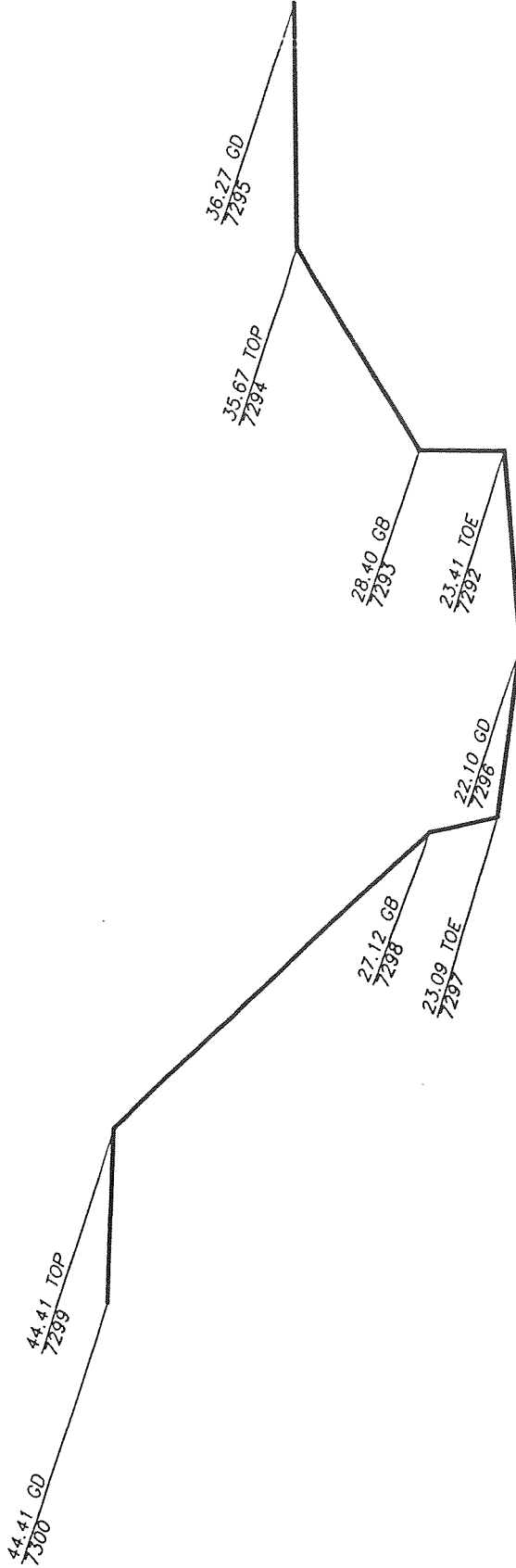

**SYCAMORE CREEK**  
**RIVER STATION 3792**  
**LOOKING DOWNSTREAM**  
UPSTREAM OF CACIQUE

**Penfield & Smith**  
ENGINEERS • SURVEYORS • PLANNERS

14643.01

14643T1

1" = 10'

**LEGEND**

17.02  
7239 —○— SPOI ELEVATION+ DESC  
SURVEY POINT #

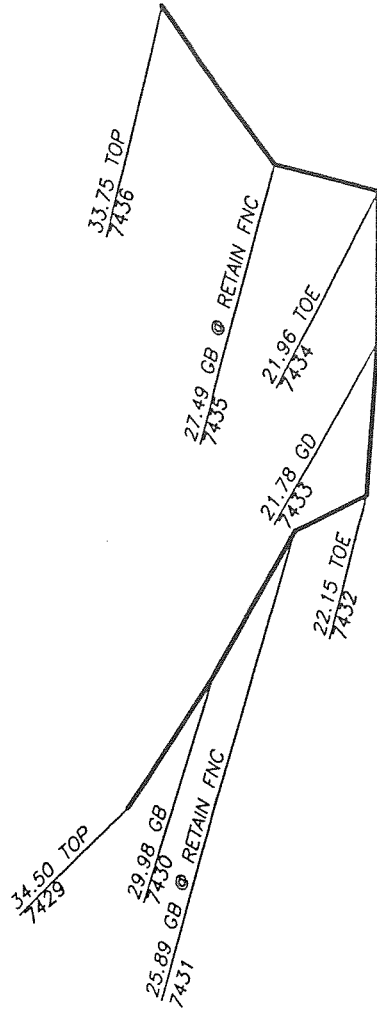

**SYCAMORE CREEK  
RIVER STATION 3837  
LOOKING DOWNSTREAM  
DOWNSTREAM OF CARPINTERIA ST.**

**Penfield & Smith**  
ENGINEERS • SURVEYORS • PLANNERS

14643.01

14643T1

1" = 10'

**LEGEND**

SPOT ELEVATION, DESCRIPTION  
POINT #

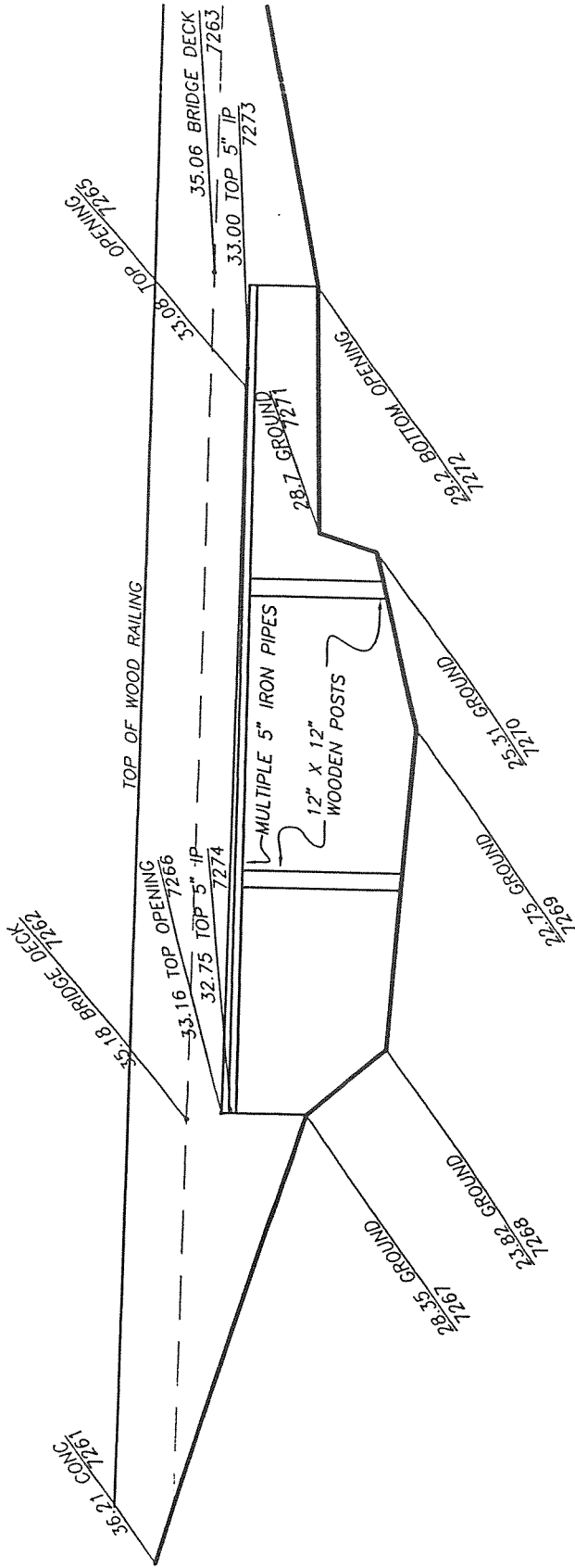

**SYCAMORE CREEK  
RIVER STATION 3914  
LOOKING UPSTREAM**

**Penfield & Smith**  
ENGINEERS • SURVEYORS • PLANNERS

14643.01 14643T01-BRG.DWG

1" = 10'

**LEGEND**

SPOT ELEVATION, DESCRIPTION  
POINT #

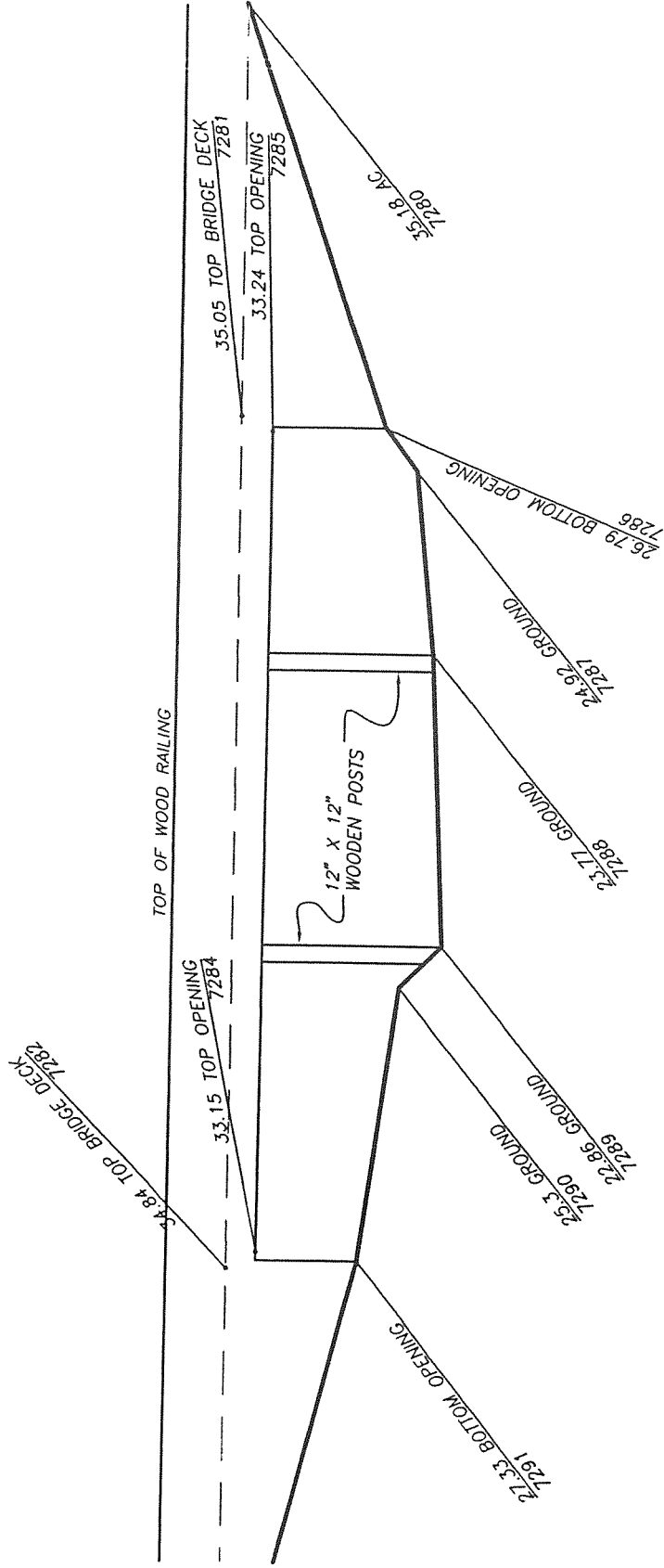

**SYCAMORE CREEK  
RIVER STATION 3953  
LOOKING DOWNSTREAM**

**Penfield & Smith**  
ENGINEERS • SURVEYORS • PLANNERS

14643.01 14643T01-BRG.DWG

1" = 10'

# LEGEND

17.02  
7239

○ SPOI ELEVATION+ DESC  
SURVEY POINT #

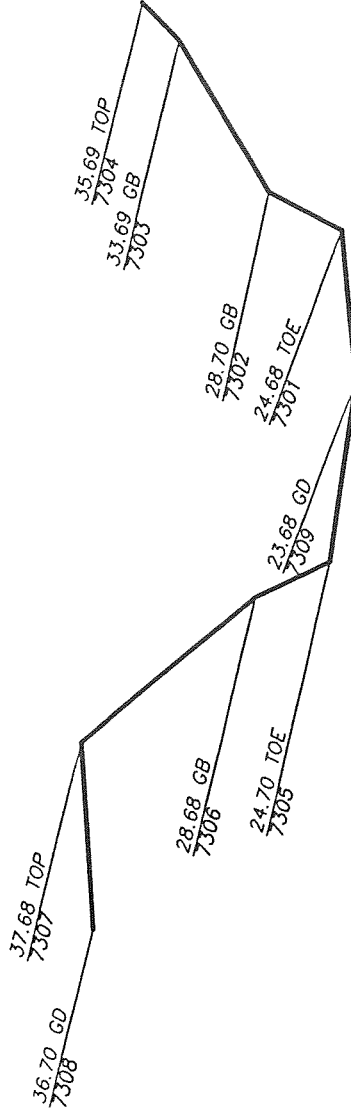

**SYCAMORE CREEK  
RIVER STATION 4018  
LOOKING DOWNSTREAM  
BETWEEN CLIFTON AND QUINIENTOS**

**Penfield & Smith**  
ENGINEERS • SURVEYORS • PLANNERS

14643.01 14643T1

1" = 10'



**LEGEND**

17.02 SPOT ELEVATION+ DESC  
7239 SURVEY POINT #

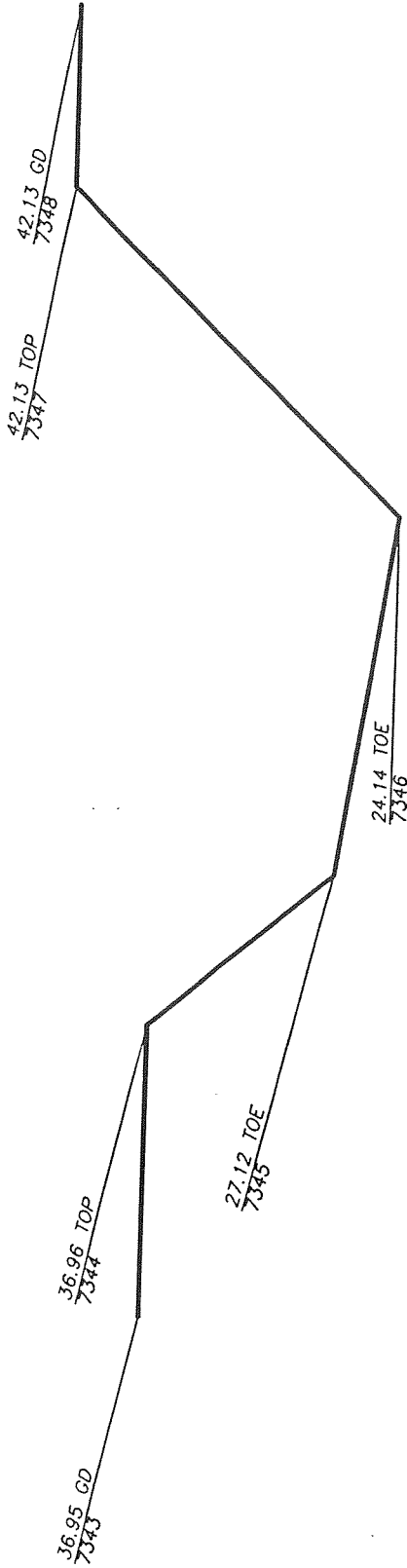

**SYCAMORE CREEK  
RIVER STATION 4322  
LOOKING DOWNSTREAM  
NEAR CANADA ST. AND CLIFTON ST.**

**Penfield & Smith**  
ENGINEERS • SURVEYORS • PLANNERS

14643.01

14643T1

1" = 10'

**SYCAMORE CREEK  
RIVER STATION 4440  
LOOKING UPSTREAM**  
QUINIENTOS BRIDGE

**LEGEND**

SPOT ELEVATION, DESCRIPTION  
POINT #

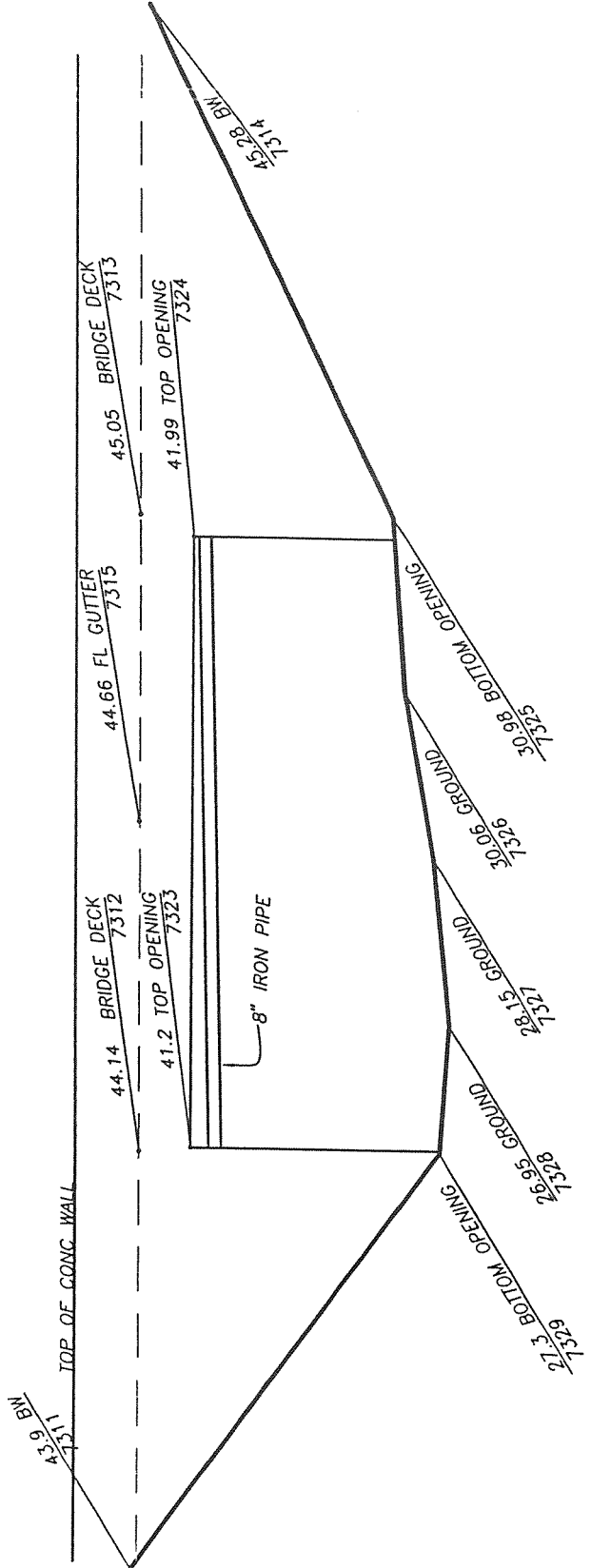

**Penfield & Smith**  
ENGINEERS • SURVEYORS • PLANNERS

14643.01 14643T01-BRG.DWG

1" = 10'

**LEGEND**

SPOT ELEVATION, DESCRIPTION  
POINT #

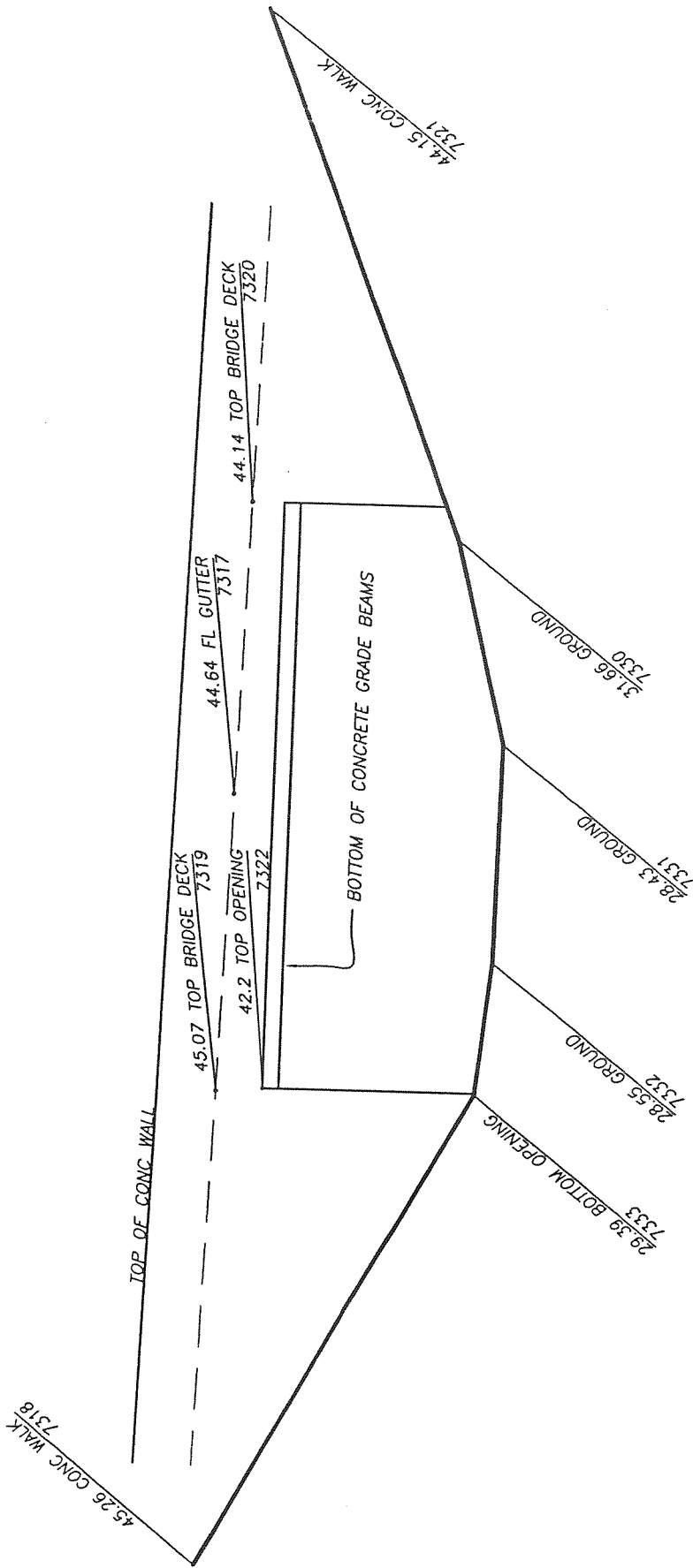

**SYCAMORE CREEK  
RIVER STATION 4484  
LOOKING DOWNSTREAM  
QUINIENTOS BRIDGE**

**Penfield & Smith**  
ENGINEERS • SURVEYORS • PLANNERS

14643.01 14643T01-BRC.DWG

1" = 10'

**LEGEND**

17.02  
7239

○ SPOT ELEVATION+ DESC  
SURVEY POINT #

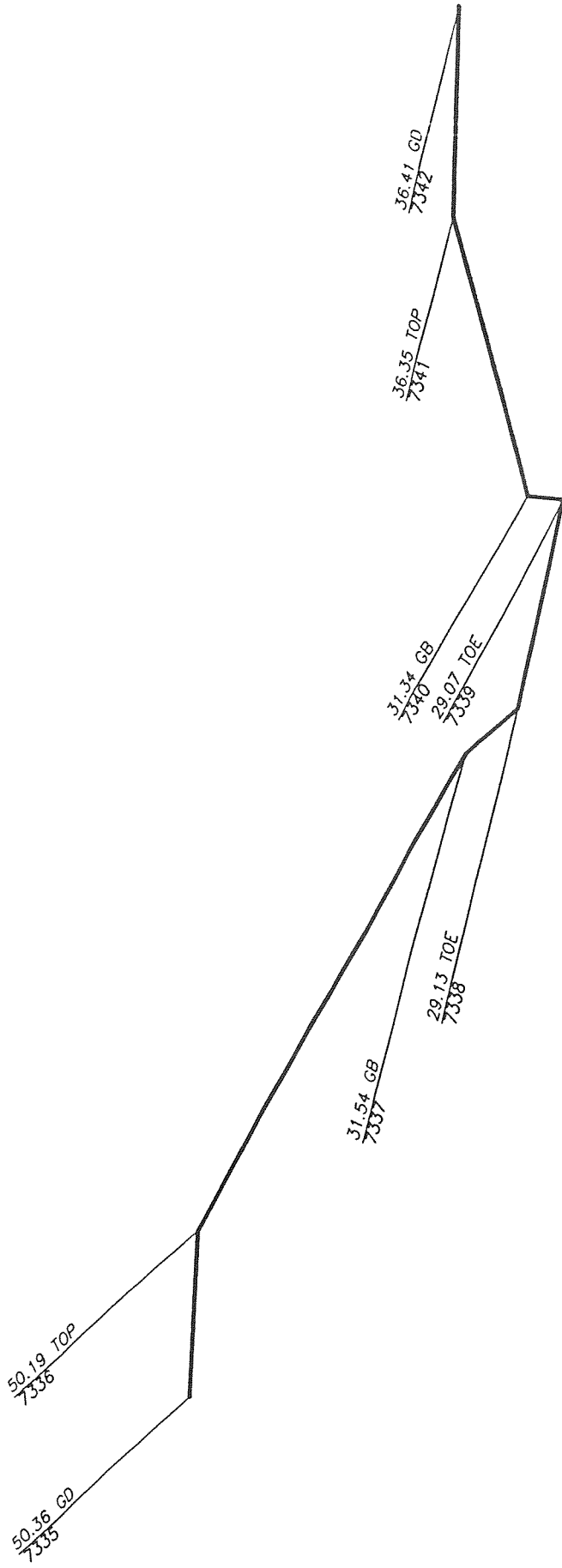

**SYCAMORE CREEK  
RIVER STATION 4574  
LOOKING DOWNSTREAM  
NEAR SALINAS PLACE**

**Penfield & Smith**  
ENGINEERS • SURVEYORS • PLANNERS

14643.01

14643T1

1" = 10'

**LEGEND**

17.02 SPOT ELEVATION+ DESC  
7239 SURVEY POINT #

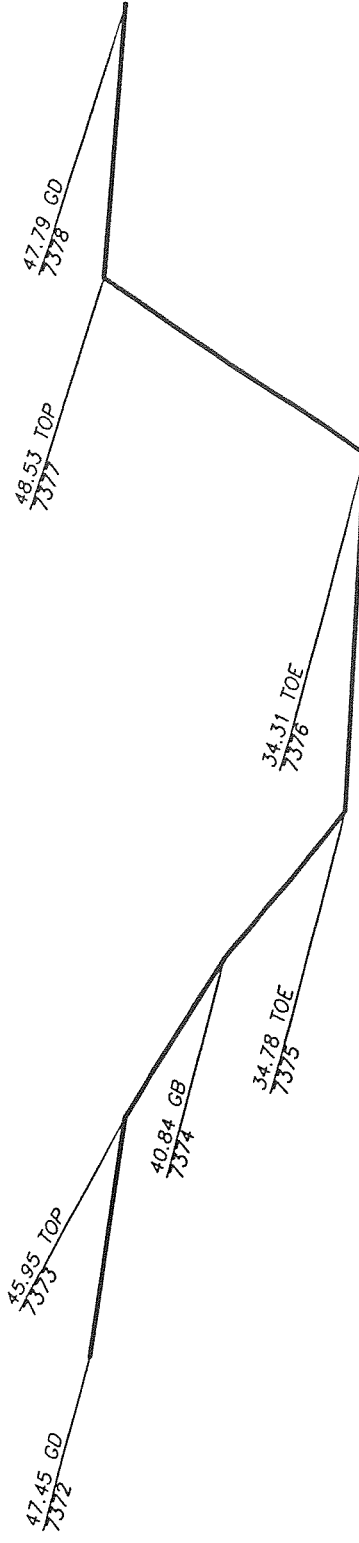

**SYCAMORE CREEK  
RIVER STATION 5021  
LOOKING DOWNSTREAM  
UPSTREAM OF SALINAS PLACE**

**Penfield & Smith**  
ENGINEERS • SURVEYORS • PLANNERS

14643.01

14643T1

1" = 10'

**SYCAMORE CREEK  
RIVER STATION 5112  
LOOKING UPSTREAM**  
MASON ST. BRIDGE

**LEGEND**

SPOT ELEVATION, DESCRIPTION  
POINT #

CMP CORRUGATED METAL PIPE

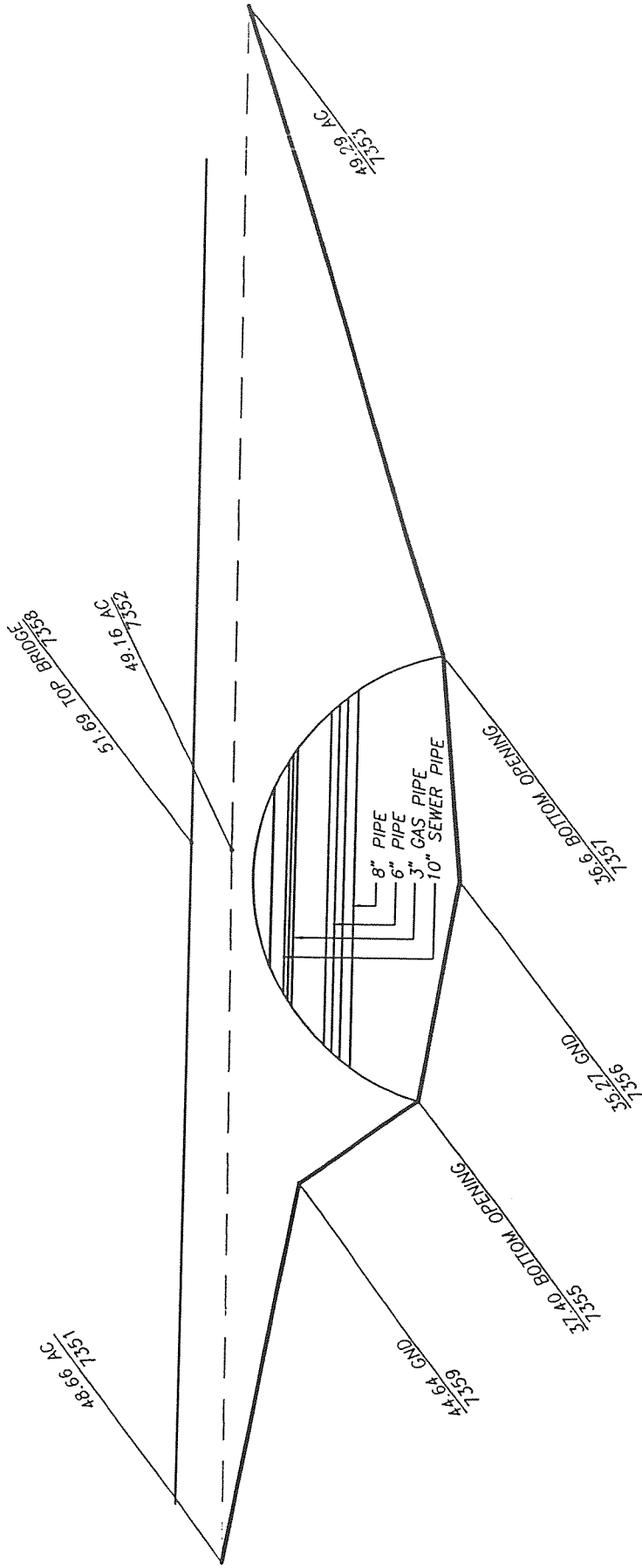

**Penfield & Smith**  
ENGINEERS • SURVEYORS • PLANNERS

14643.01 14643T01—BRG.DWG

1" = 10'

**SYCAMORE CREEK  
RIVER STATION 5150  
LOOKING DOWNSTREAM  
MASON ST. BRIDGE**

**LEGEND**

SPOT ELEVATION, DESCRIPTION  
POINT #

CMP CORRUGATED METAL PIPE

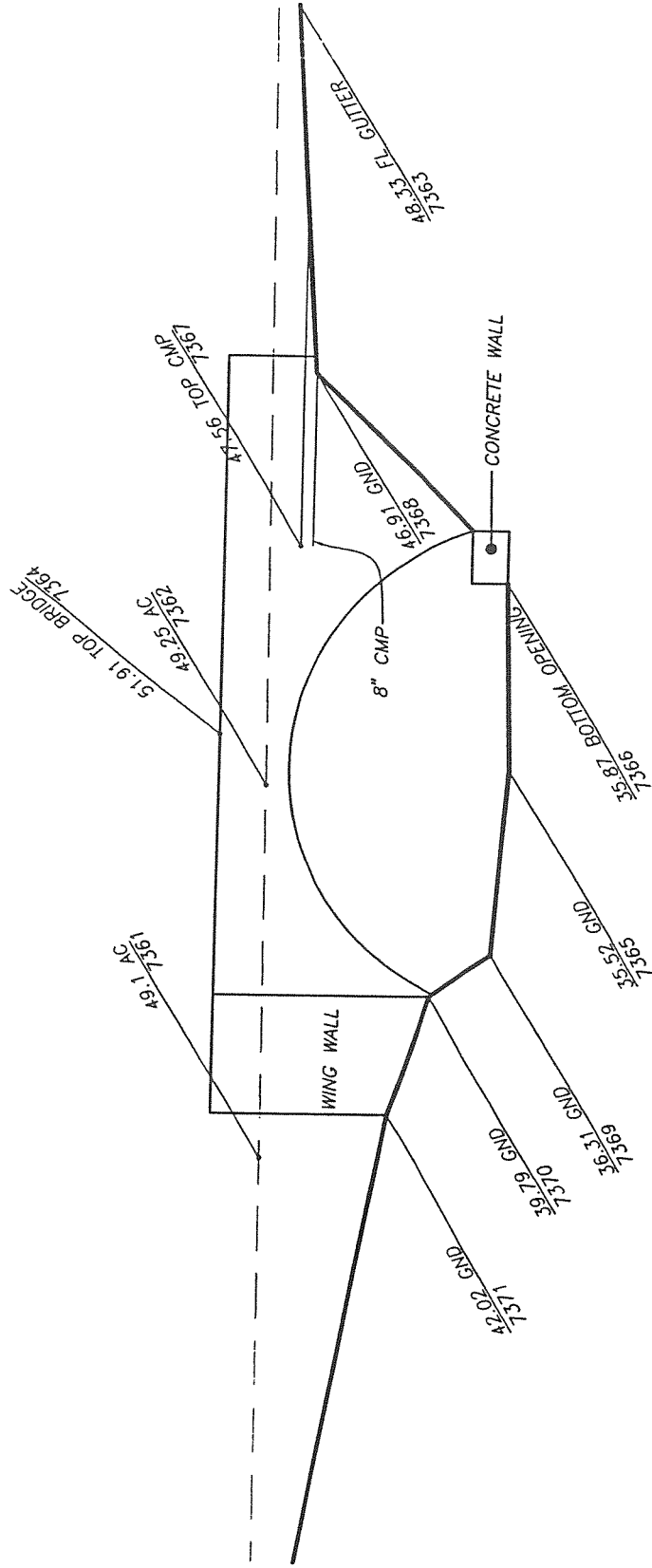

**Penfield & Smith**  
ENGINEERS • SURVEYORS • PLANNERS

14643.01 14643T01-BRG.DWG

1" = 10'

**LEGEND**

17.02  
7239 —○— SPOT ELEVATION+ DESC  
SURVEY POINT #

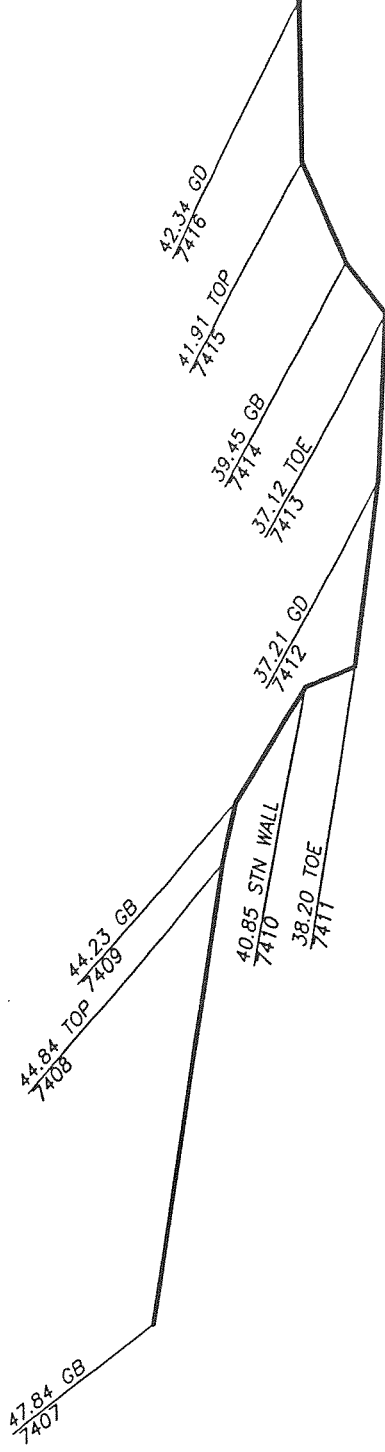

**SYCAMORE CREEK  
RIVER STATION 5300  
LOOKING DOWNSTREAM  
UPSTREAM OF MASON STREET**

**Penfield & Smith**  
ENGINEERS • SURVEYORS • PLANNERS

14643.01 14643T1

1" = 10'



**LEGEND**

17.02  
7239 —○— SPOT ELEVATION ±\_DESC  
SURVEY POINT #

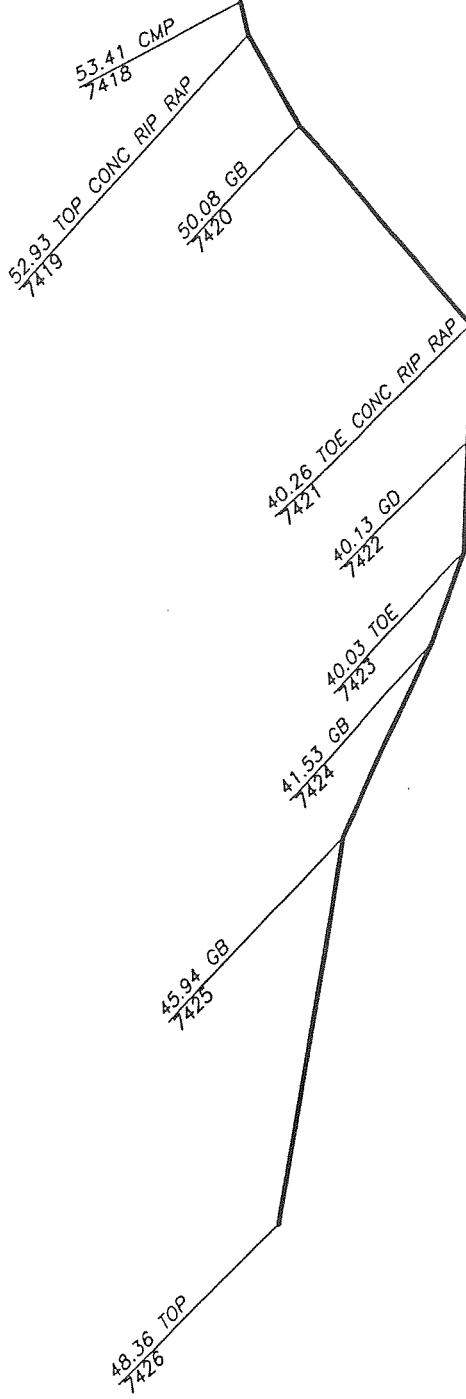

**SYCAMORE CREEK  
RIVER STATION 5535  
LOOKING DOWNSTREAM  
BETWEEN CITRUS AVE. AND SYCAMORE LN.**

**Penfield & Smith**  
ENGINEERS • SURVEYORS • PLANNERS

14643.01 14643T1

1" = 10'

**LEGEND**

SPOT ELEVATION, DESCRIPTION  
POINT #

CMP CORRUGATED METAL PIPE

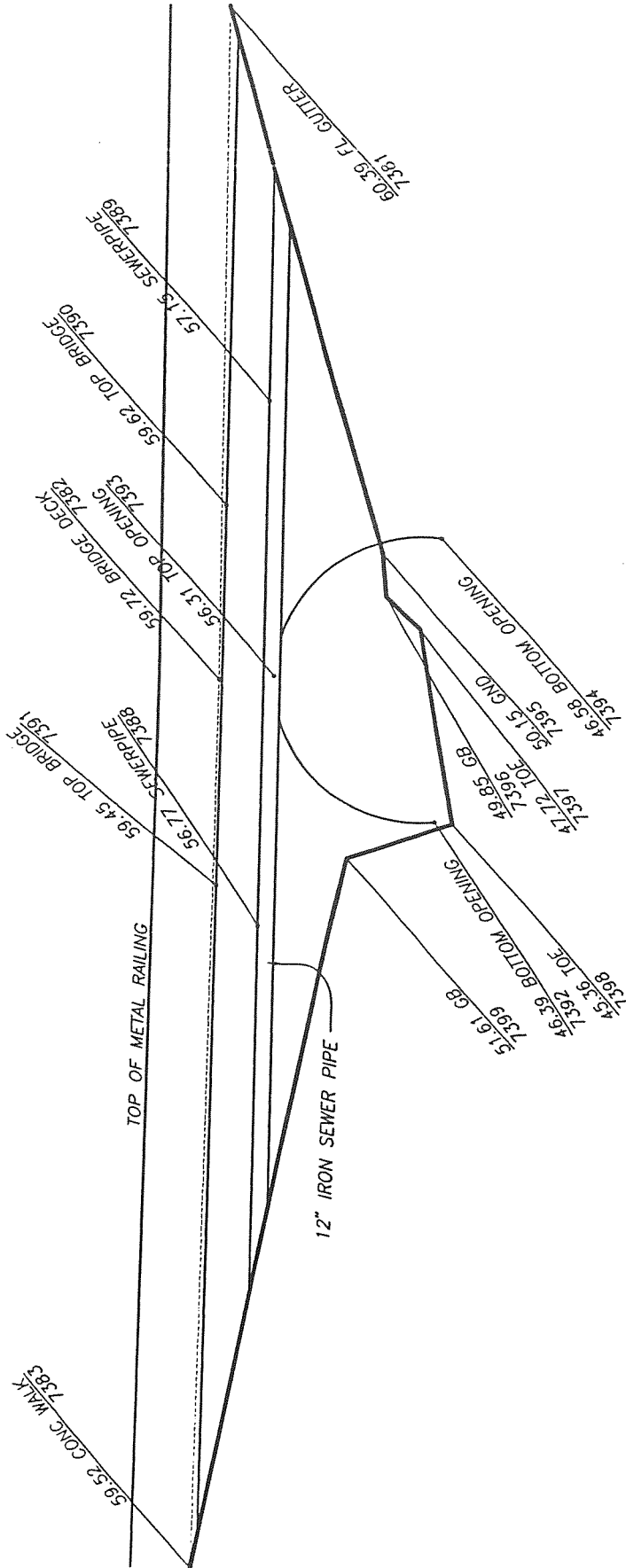

**SYCAMORE CREEK  
RIVER STATION 6139  
LOOKING UPSTREAM  
YANONALI BRIDGE**

**Penfield & Smith**  
ENGINEERS • SURVEYORS • PLANNERS

14643.01 14643T01 - BRG.DWG

1" = 10'

**LEGEND**

SPOT ELEVATION, DESCRIPTION  
POINT #

CMP CORRUGATED METAL PIPE

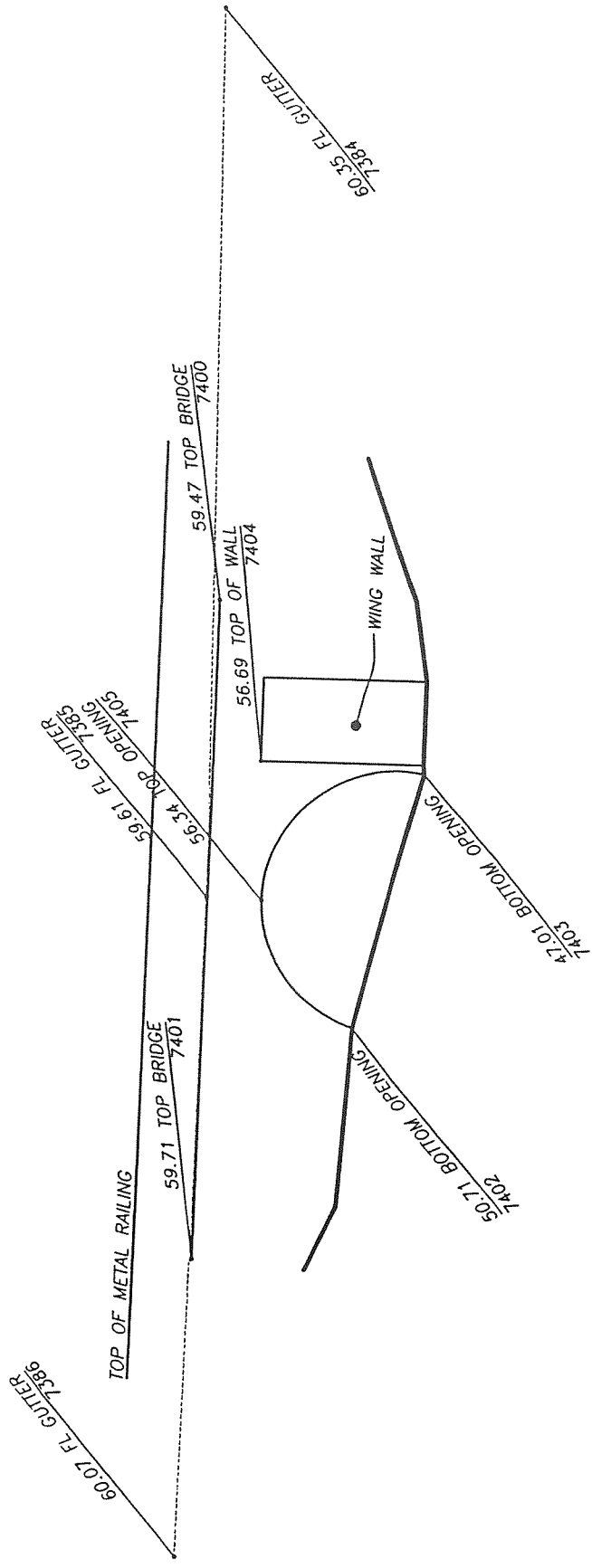

**SYCAMORE CREEK  
RIVER STATION 6167  
LOOKING DOWNSTREAM  
YANONALI BRIDGE**

**Penfield & Smith**  
ENGINEERS • SURVEYORS • PLANNERS

14643.01 14643T01-BRG.DWG 1" = 10'

**HEC-RAS Cross Sections and Profiles  
For Existing Conditions**

# SYCAMORE CREEK REACH EXISTING CAPACITY RESULTS

Project Number: 14643.01  
 Description: SYCAMORE CREEK  
 Client: County Flood Control  
 Date: 10/29/2003  
 File: 14643CAPACITIES.xls

Prepared By: **Penfield Smith**  
 P.O. Box 98  
 Santa Barbara, CA 93102  
 (805)963-9532

REACH #	REACH NAME	RIVER STATION RANGE	W/ BRIDGES	W/O BRIDGES
			Reach Capacity (cfs)	Reach Capacity (cfs)
1	East Beach Pedestrian Bridge	334 to 344	3200	4500
2	Cabrillo Blvd Bridge	344 to 465	3000	3000
3	Between Cabrillo and Por La Mar Circle #1	604	3200	6000
4	Por La Mar Circle Bridge #1	710 to 755	1800	4000
5	Between Por La Mar Circle #1 and #2	932	1800	3500
6	Por La Mar Circle Bridge #2	1110 to 1161	1500	2200
7	Between Por La Mar Circle #2 and Zoo	1214	1600	2900
8	Zoo Bridge	1270 to 1328	1100	1500
9	Between Zoo and Railroad	1510	1300	1400
10	Railroad Bridge	1652 to 1674	2400	4000
11	101 Bridge	1723 to 1831	800	1200
12	Between 101 and Punta Gorda	2051	1300	2600
13	Punta Gorda Bridge	2144 to 2181	1400	1800
14	Between Punta Gorda and Indio Muerto	2294 to 2529	2000	2500
15	Indio Muerto Bridge	2729 to 2773	1200	2000
16	Between Indio Muerto and Cacique Street	2805 to 3198	1200	2000
17	Cacique Street Bridge	3277 to 3287	2500	3000
18	Between Cacique and Carpinteria	3792 to 3837	3200	2900
19	Carpinteria Bridge	3914 to 3953	2600	2900
20	Between Carpinteria and Quinientos	4018 to 4322	2400	3200
21	Quinientos Bridge	4440 to 4484	6000	6000
22	Between Quinientos and Mason	4574 to 5021	5000	6000
23	Mason Street Bridge	5112 to 5150	2500	4000
24	Between Mason and Yanonali	5300 to 5535	2500	2500
25	Yanonali Bridge	6139 to 6167	1400	5000

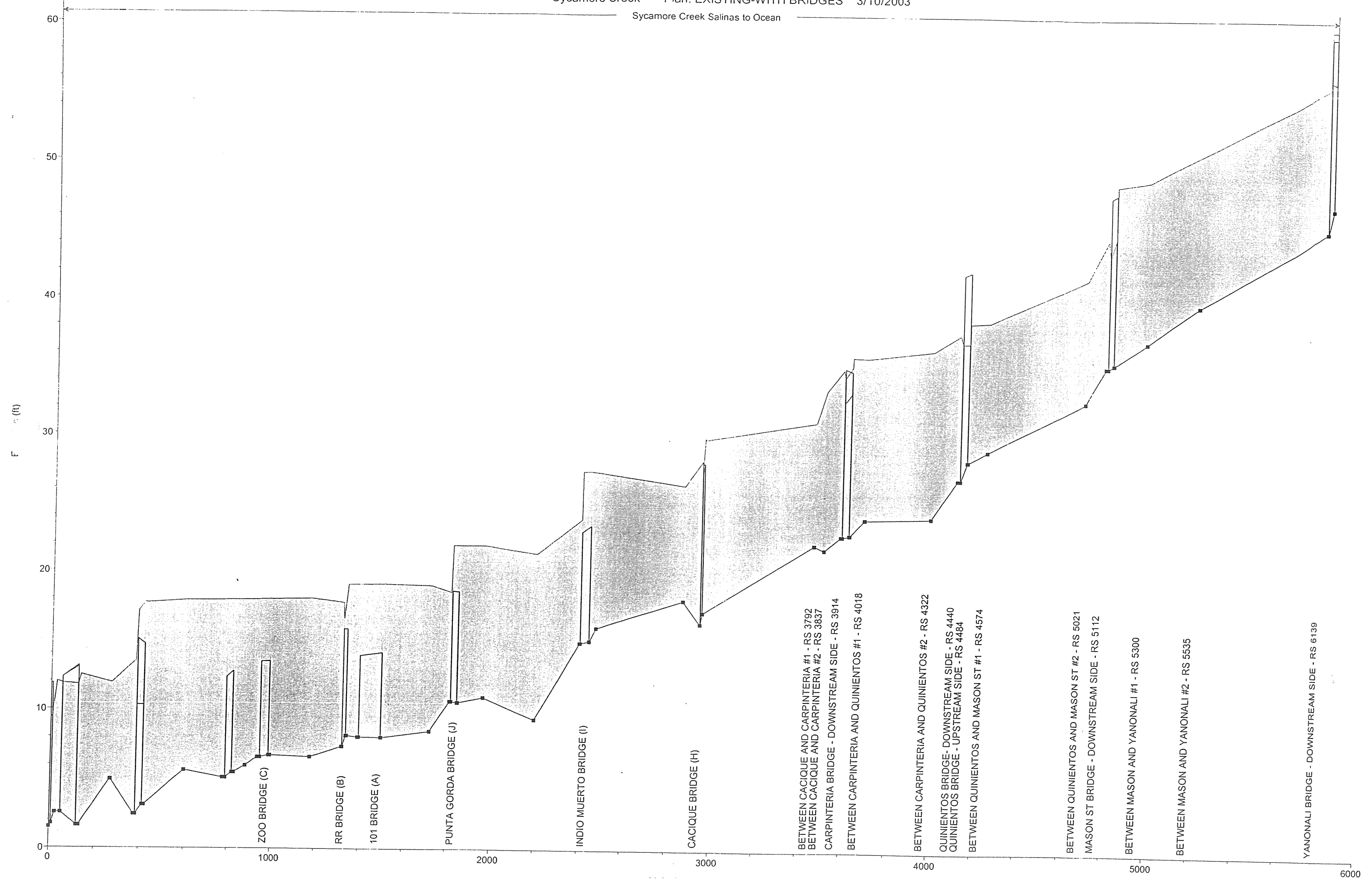

Legend  
WS 300  
Ground

Sycamore Creek Plan: EXISTING-WITH BRIDGES 3/10/2003  
 RS = 6167.572 YANONALI BRIDGE-UPSTREAM SIDE - RS 6167

Legend	
—■—	WS 3000
—■—	WS 2500
—■—	WS 2000
—■—	WS 1500
—■—	WS 1000
—	Ground
—○—	Levee
—●—	Bank Sta

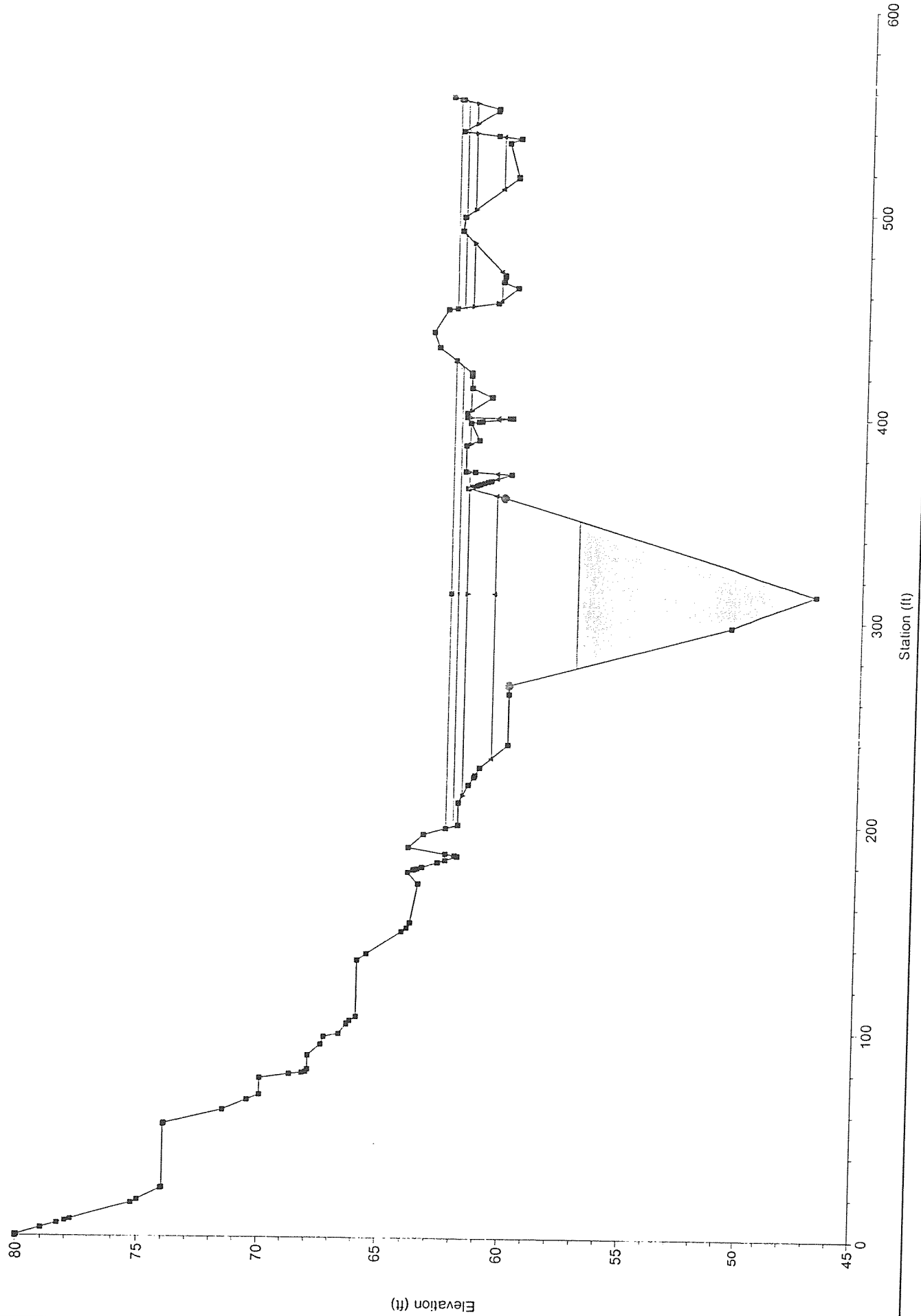

Sycamore Creek Plan: EXISTING-WITH BRIDGES 3/10/2003  
 RS = 6141 BR YANONALI BRIDGE

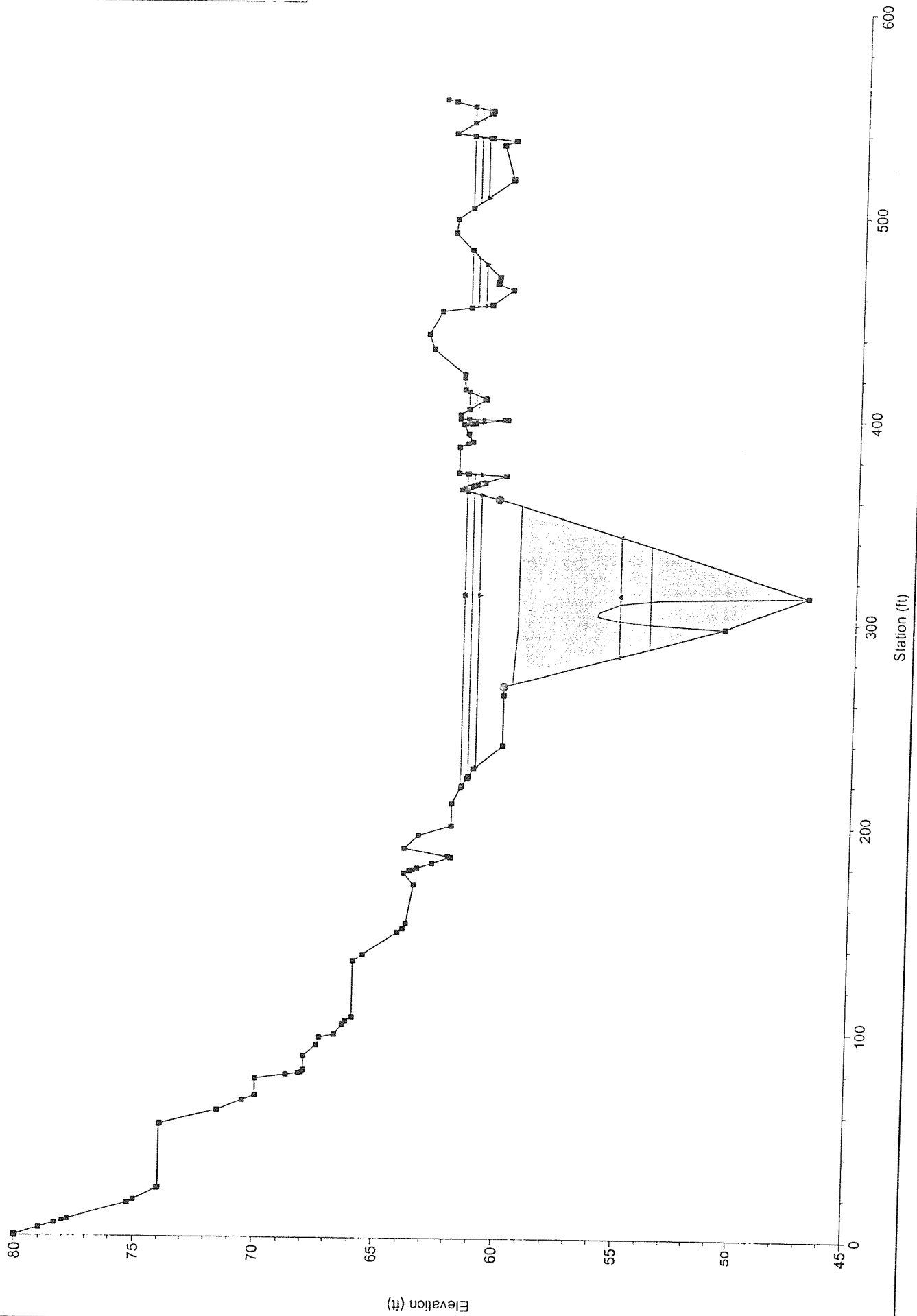

Legend	
—●—	WS 3000
—●—	WS 2500
—●—	WS 2000
—●—	WS 1500
—●—	WS 1000
—	Ground
- - -	Levee
○	Bank Sta



Sycamore Creek Plan: EXISTING-WITH BRIDGES 3/10/2003  
 RS = 6141 BR YANONALI BRIDGE

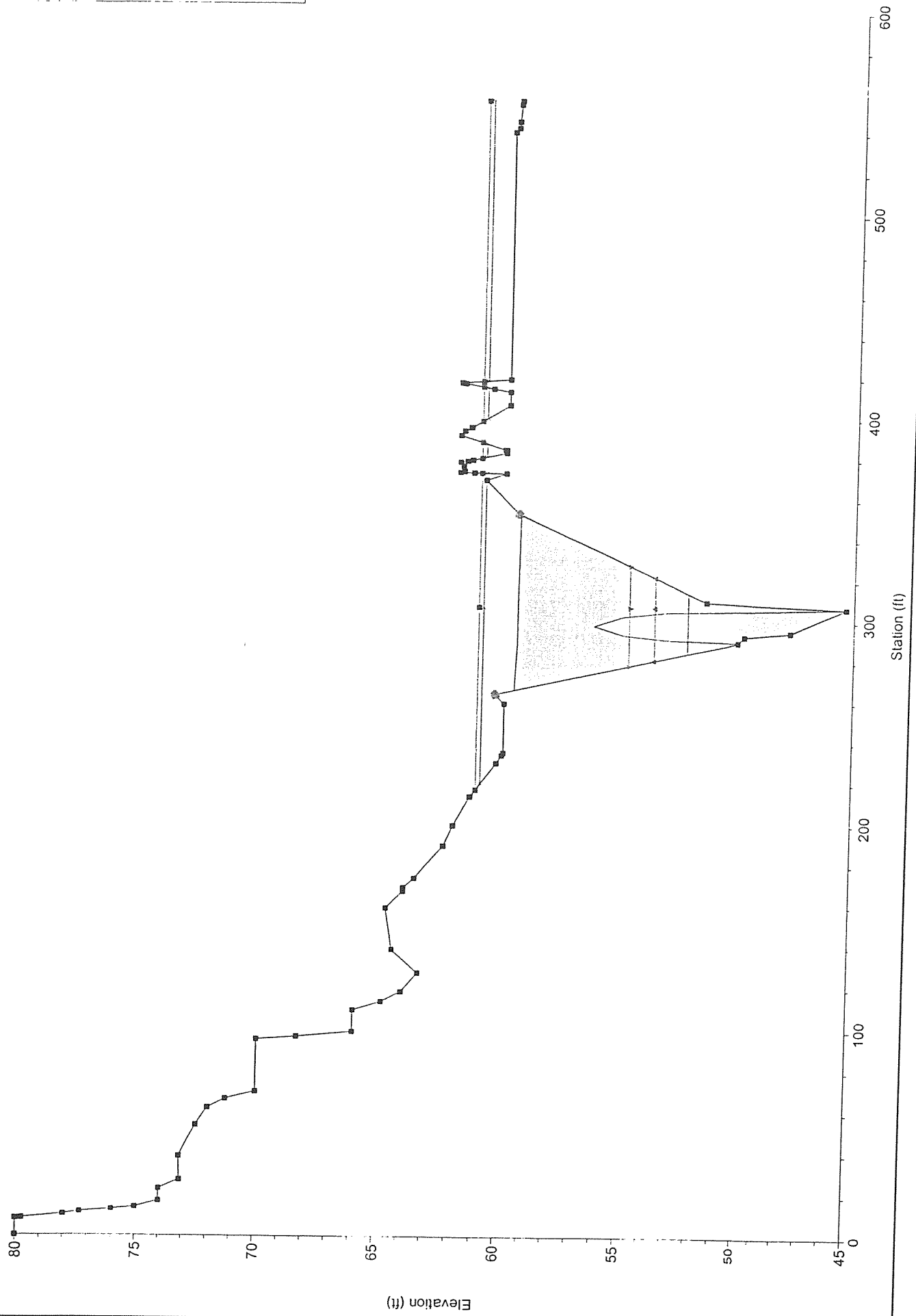

Legend	
WS 3000	—
WS 2500	—
WS 2000	—
WS 1500	—
WS 1000	—
Ground	—
Levee	—
Bank Sta	—

Sycamore Creek Plan: EXISTING-WITH BRIDGES 3/10/2003  
 RS = 6139.279 YANONALI BRIDGE - DOWNSTREAM SIDE - RS 6139

Legend	
—	WS 3000
—	WS 2500
—	WS 2000
—	WS 1500
—	WS 1000
—	Ground
—	Levee
—	Bank Sta

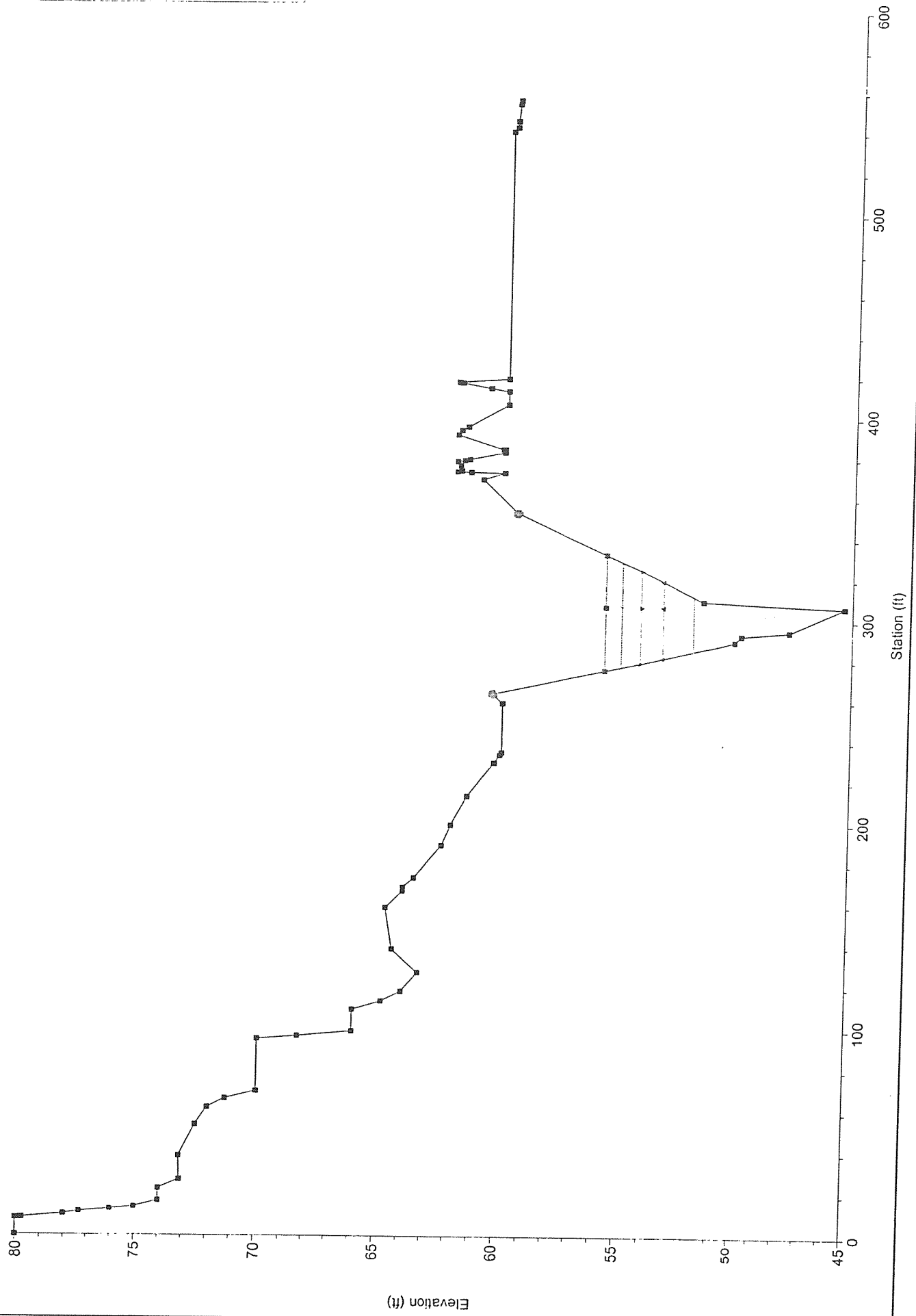

Sycamore Creek Plan: EXISTING-WITH BRIDGES 3/10/2003  
 RS = 5535.950 BETWEEN MASON AND YANONALI #2 - RS 5535

Legend	
—	WS 3000
—	WS 2500
—	WS 2000
—	WS 1500
—	WS 1000
—	Ground
—	Levee
—	Bank Sta

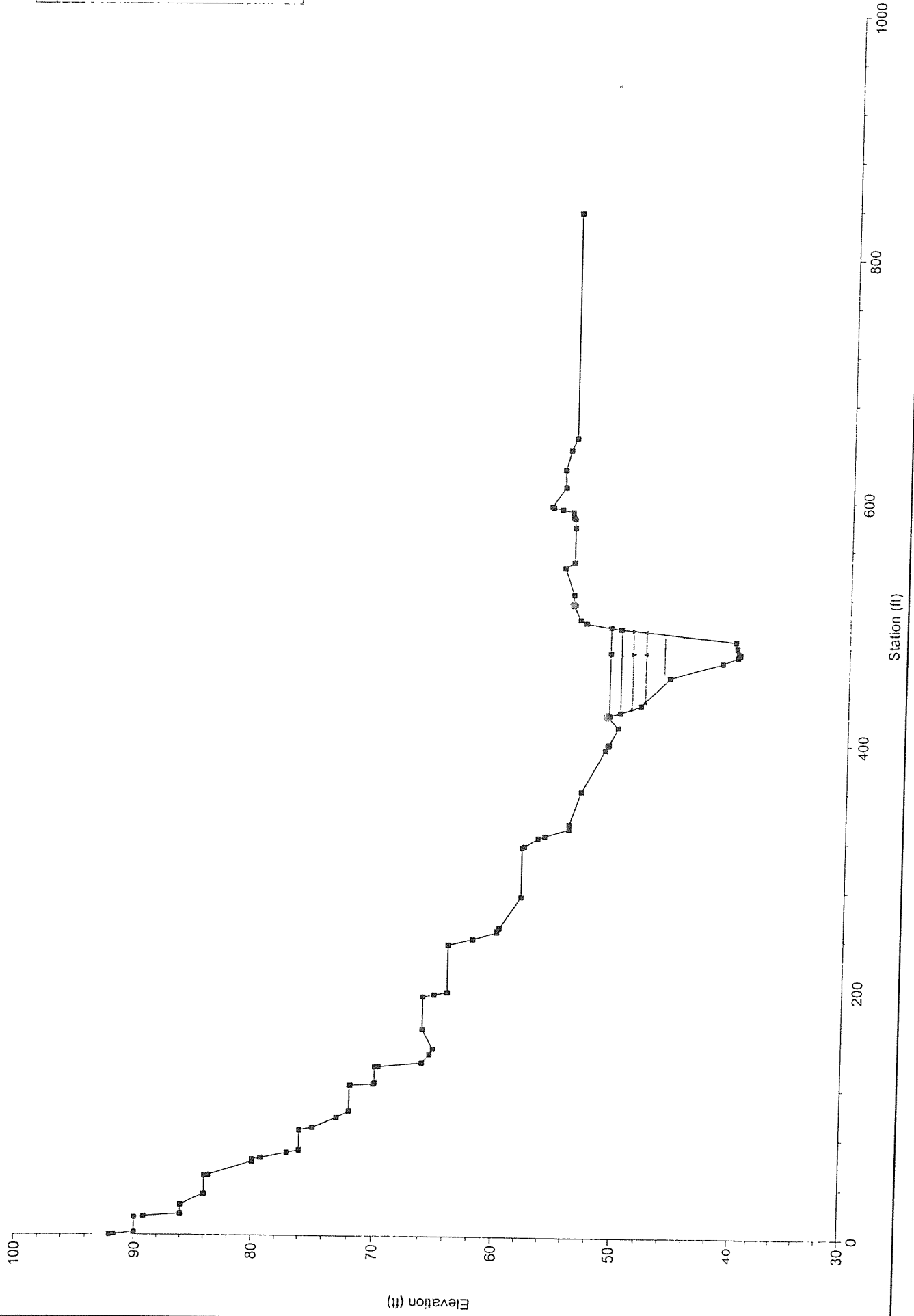

Sycamore Creek Plan: EXISTING-WITH BRIDGES 3/10/2003  
 RS = 5300.376 BETWEEN MASON AND YANONALI #1 - RS 5300

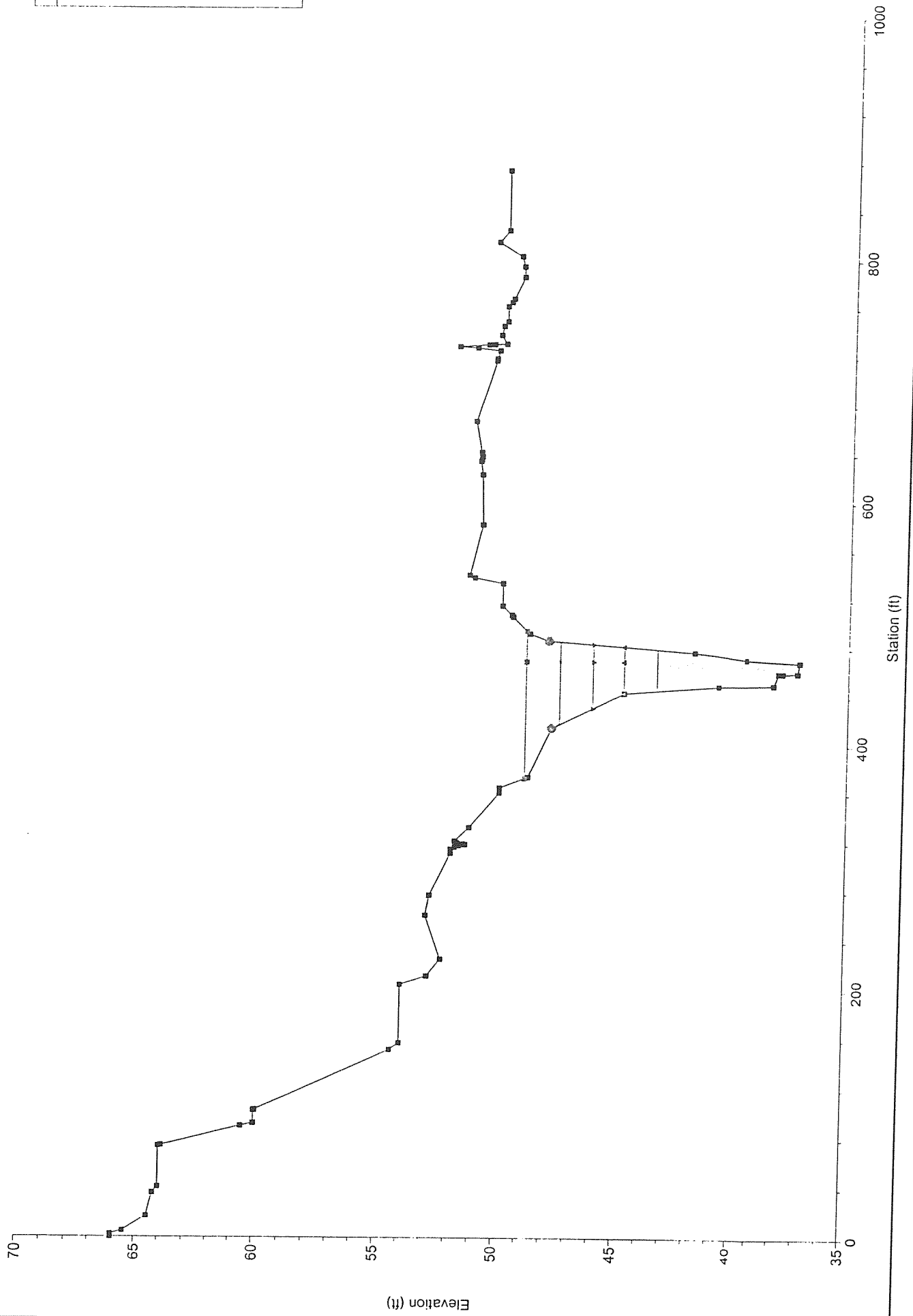

Legend	
WS 3000	□
WS 2500	▽
WS 2000	△
WS 1500	◇
WS 1000	○
Ground	—
Levee	- - -
Bank Sta	⊗

Sycamore Creek Plan: EXISTING-WITH BRIDGES 3/10/2003  
 RS = 5150.584 MASON ST BRIDGE - UPSTREAM SIDE - RS 5150

Legend	
■	WS 3000
■	WS 2500
■	WS 2000
■	WS 1500
■	WS 1000
○	Ground
○	Levee
○	Bank Sta

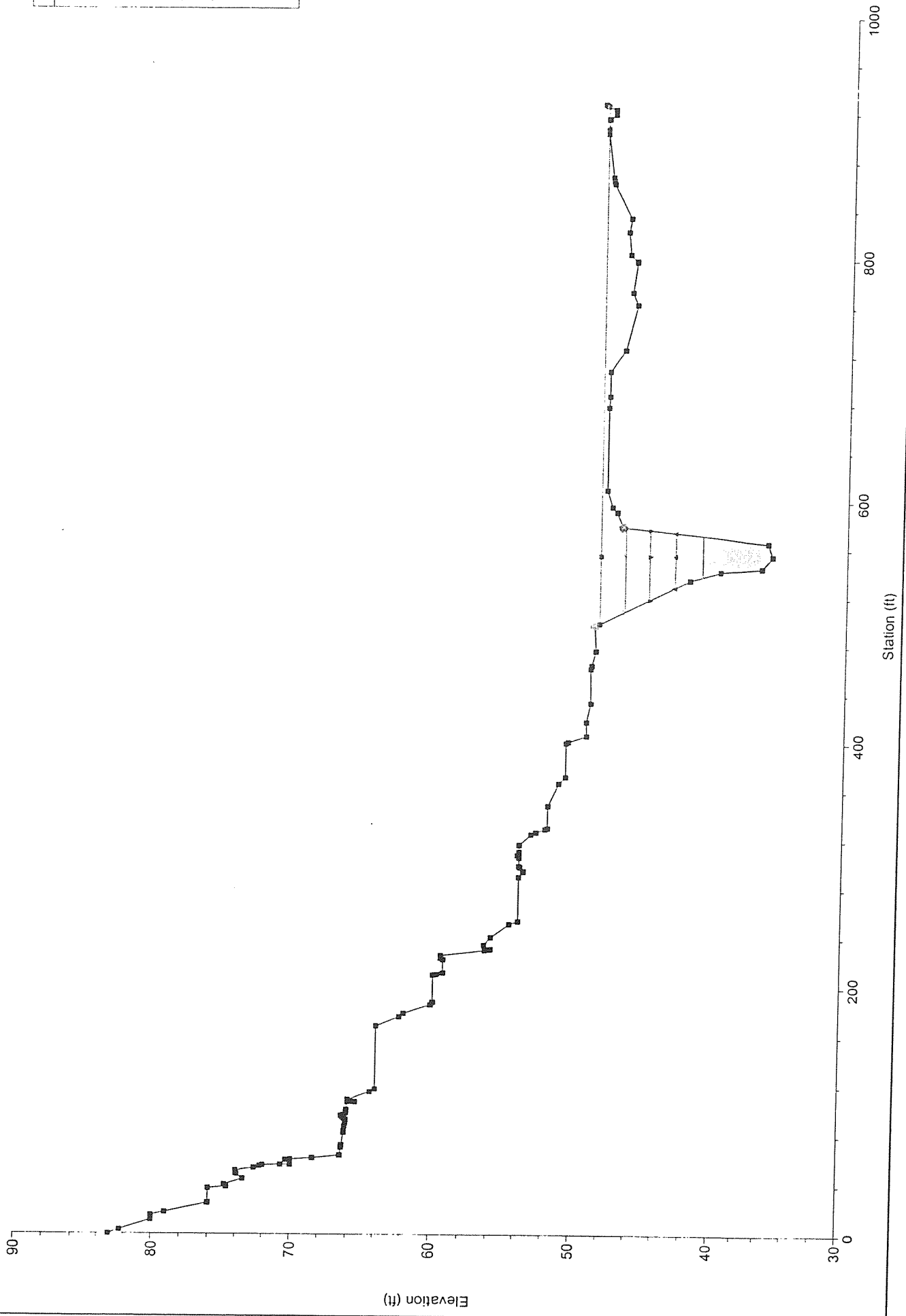

Sycamore Creek Plan: EXISTING-WITH BRIDGES 3/10/2003  
 RS = 5123 BR MASON ST BRIDGE (L)

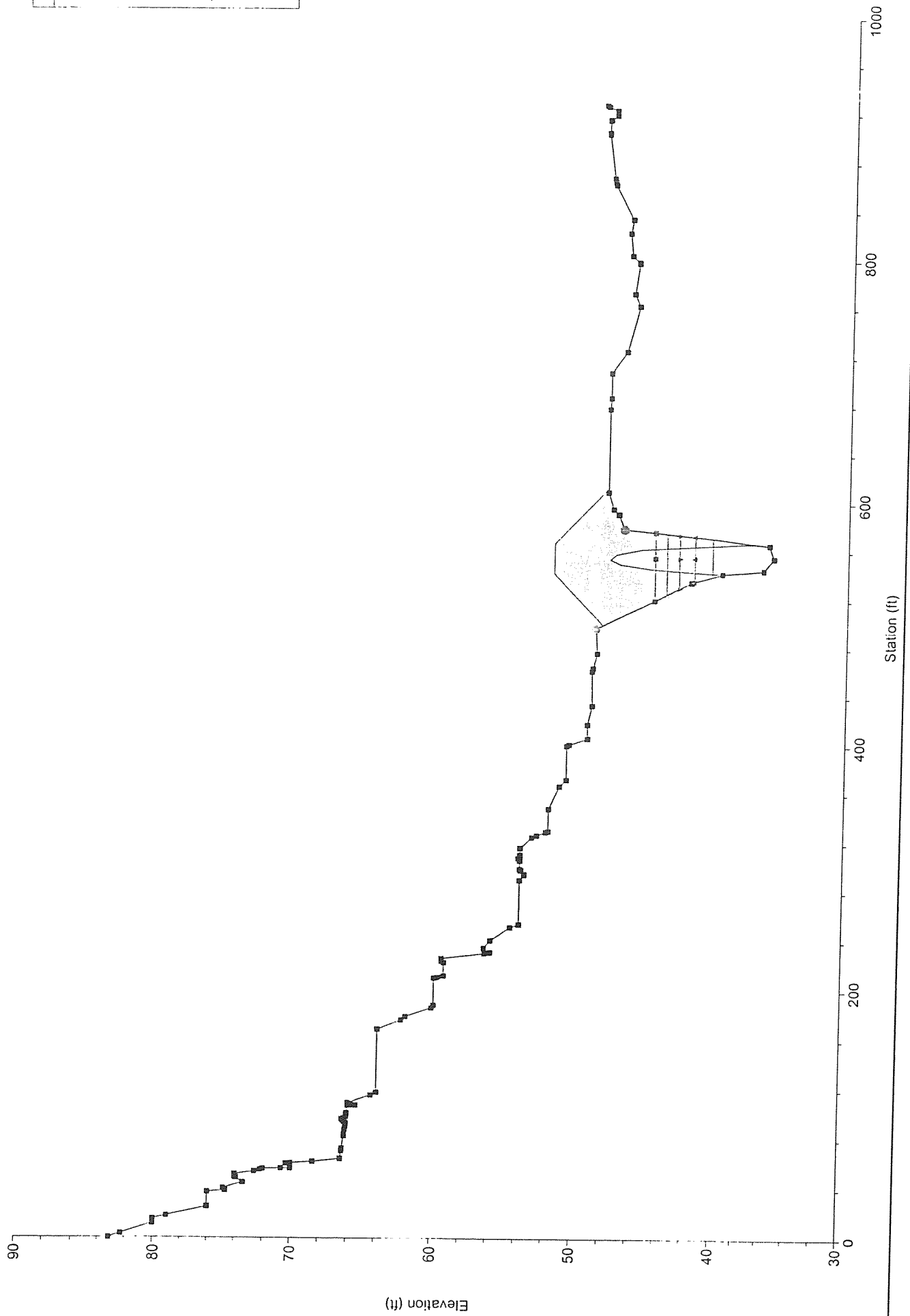

Legend
WS 3000
WS 2500
WS 2000
WS 1500
WS 1000
Ground
Levee
Bank Sta

Sycamore Creek Plan: EXISTING-WITH BRIDGES 3/10/2003  
RS = 5123 BR MASON ST BRIDGE (L)

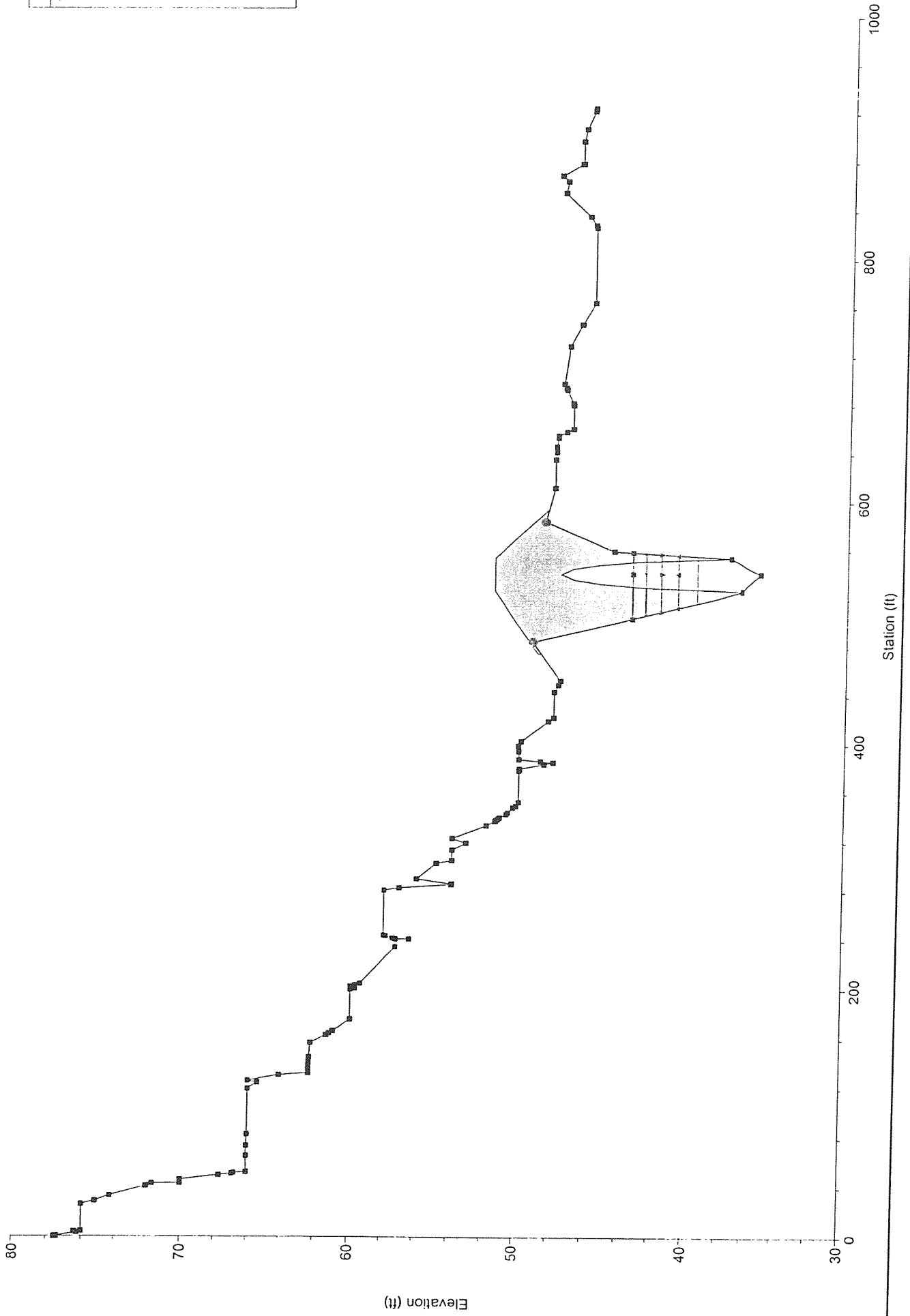

Legend	
—■—	WS 3000
- - -	WS 2500
- · - · -	WS 2000
- - - - -	WS 1500
- - - - -	WS 1000
—	Ground
—○—	Levee
—■—	Bank Sta

Sycamore Creek Plan: EXISTING-WITH BRIDGES 3/10/2003  
 RS = 5112.741 MASON ST BRIDGE - DOWNSTREAM SIDE - RS 5112

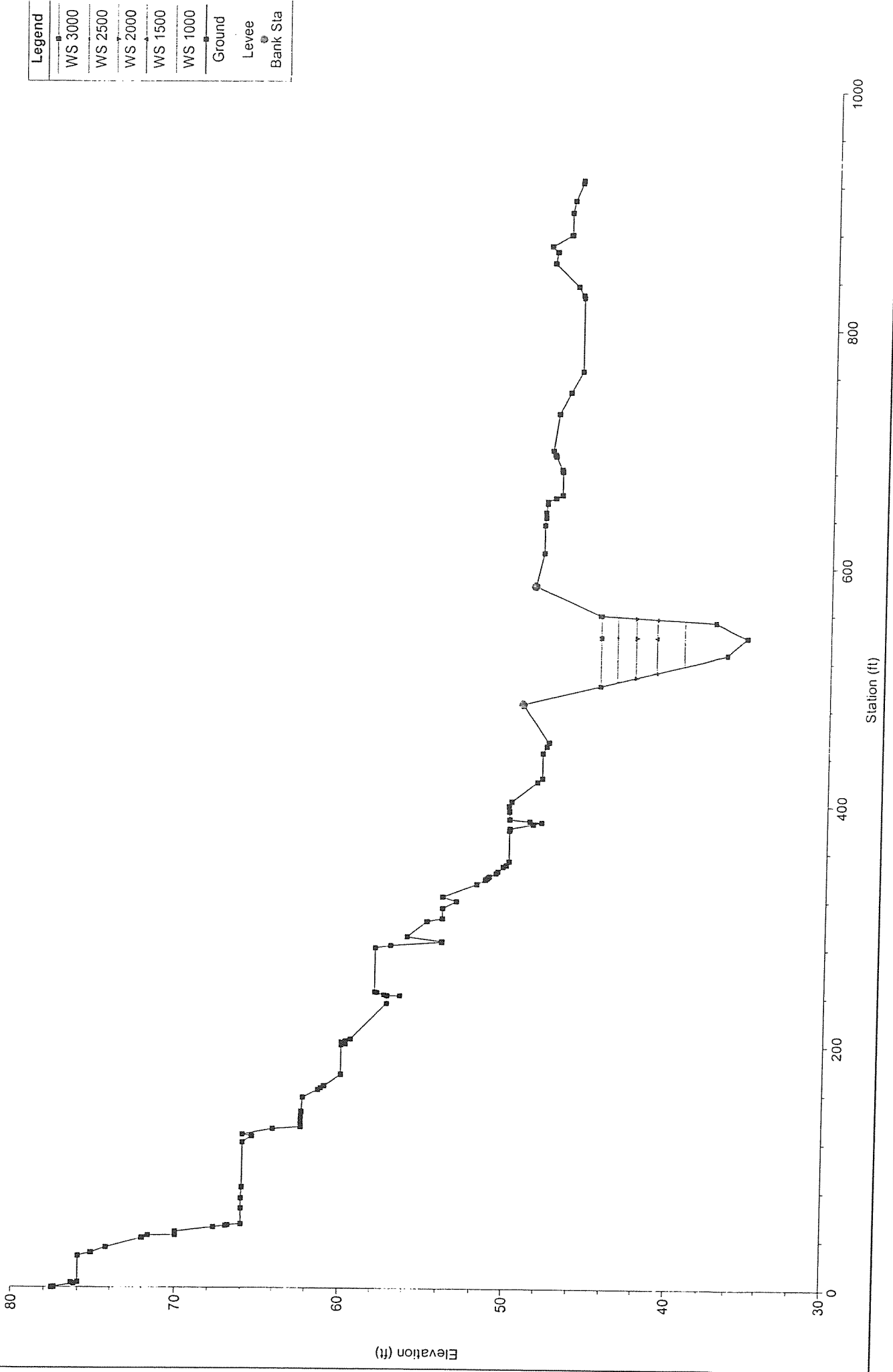



Sycamore Creek Plan: EXISTING-WITH BRIDGES 3/10/2003  
 RS = 5021.315 BETWEEN QUINIENTOS AND MASON ST #2 - RS 5021

Legend	
—	WS 3000
—	WS 2500
—	WS 2000
—	WS 1500
—	WS 1000
—	Ground
—	Levee
—	Bank Sta

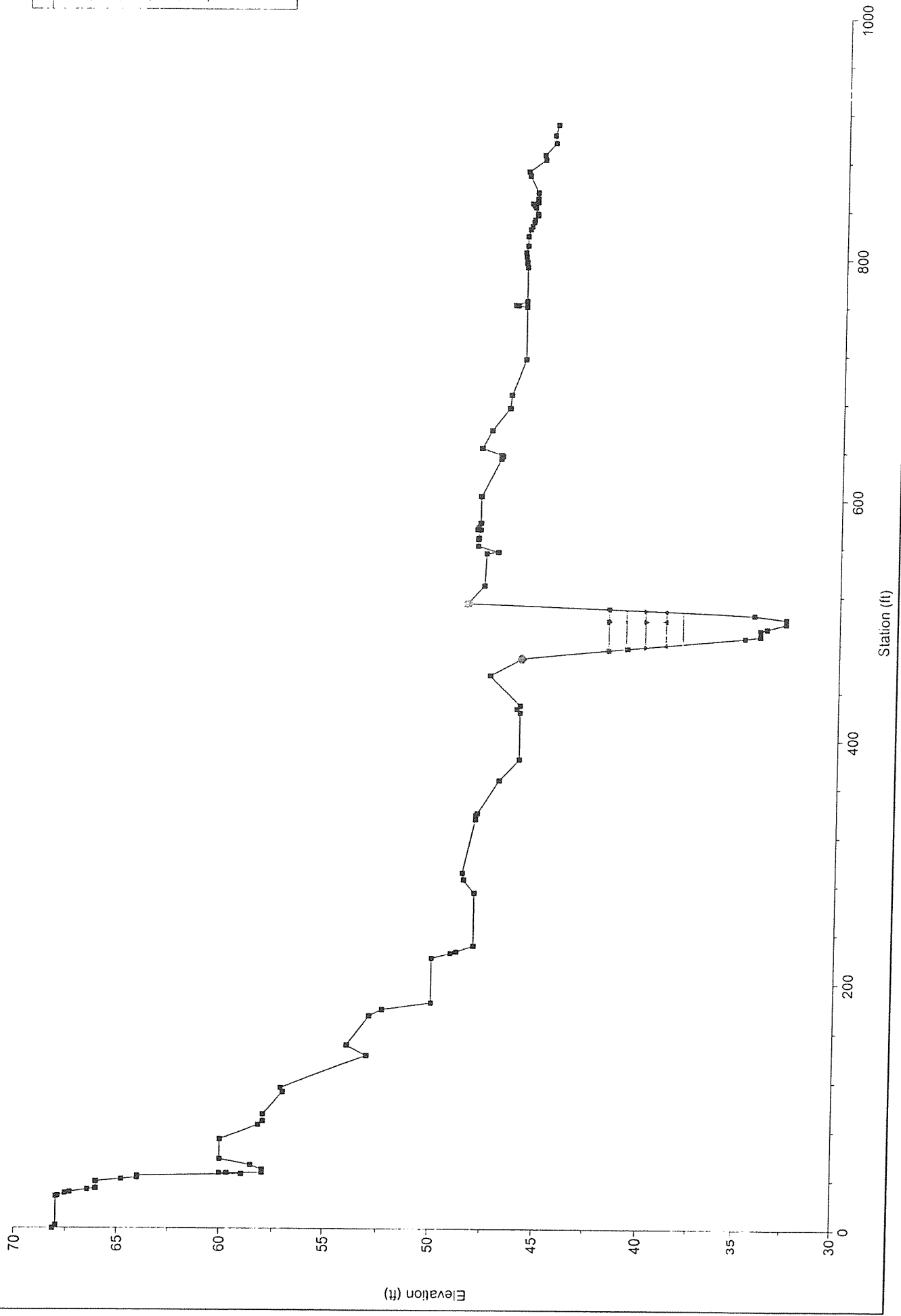

Sycamore Creek Plan: EXISTING-WITH BRIDGES 3/10/2003  
 RS = 4574.630 BETWEEN QUINIENTOS AND MASON ST #1 - RS 4574

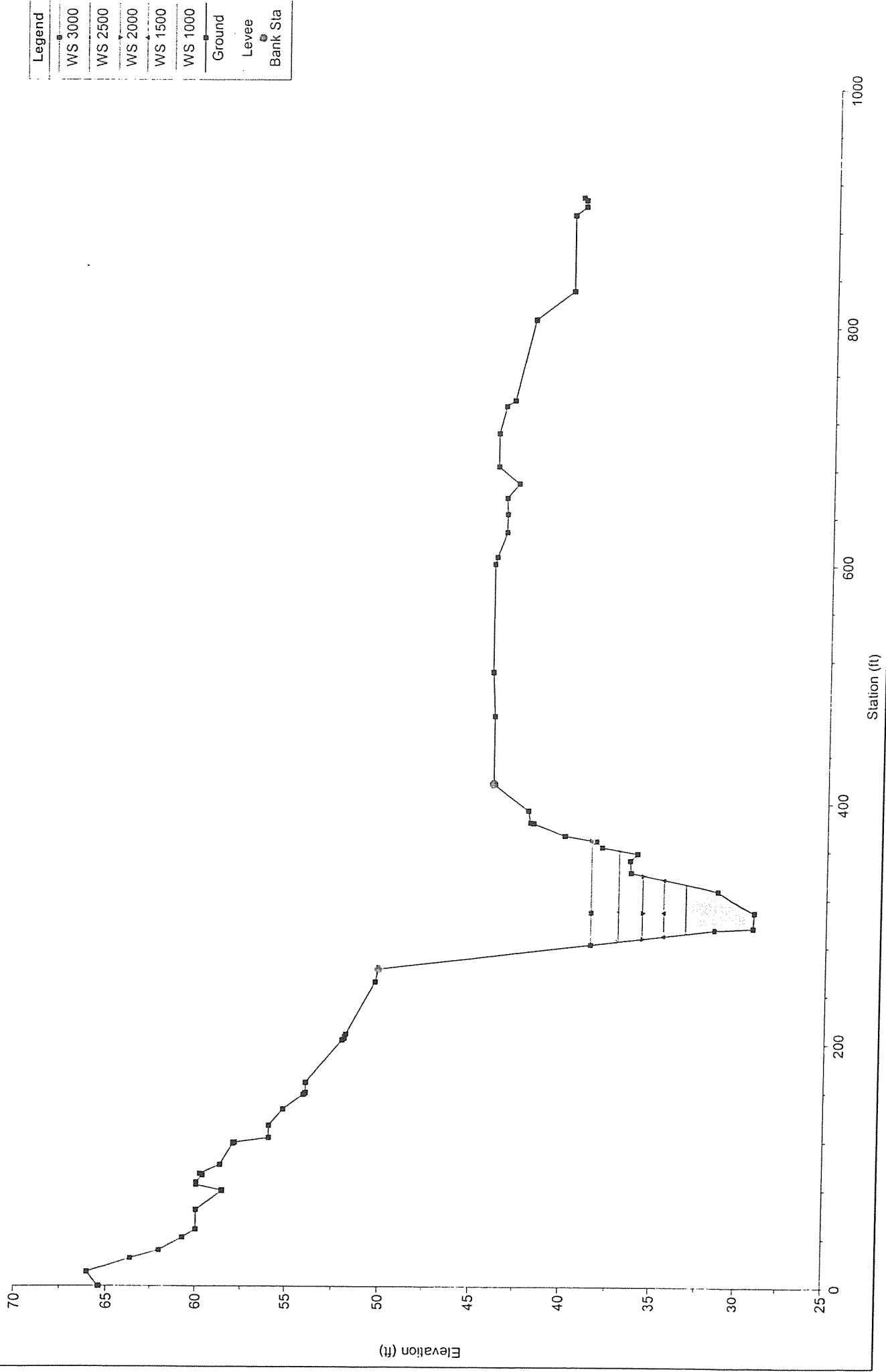

Sycamore Creek Plan: EXISTING-WITH BRIDGES 3/10/2003  
 RS = 4484.828 QUINIENTOS BRIDGE - UPSTREAM SIDE - RS 4484

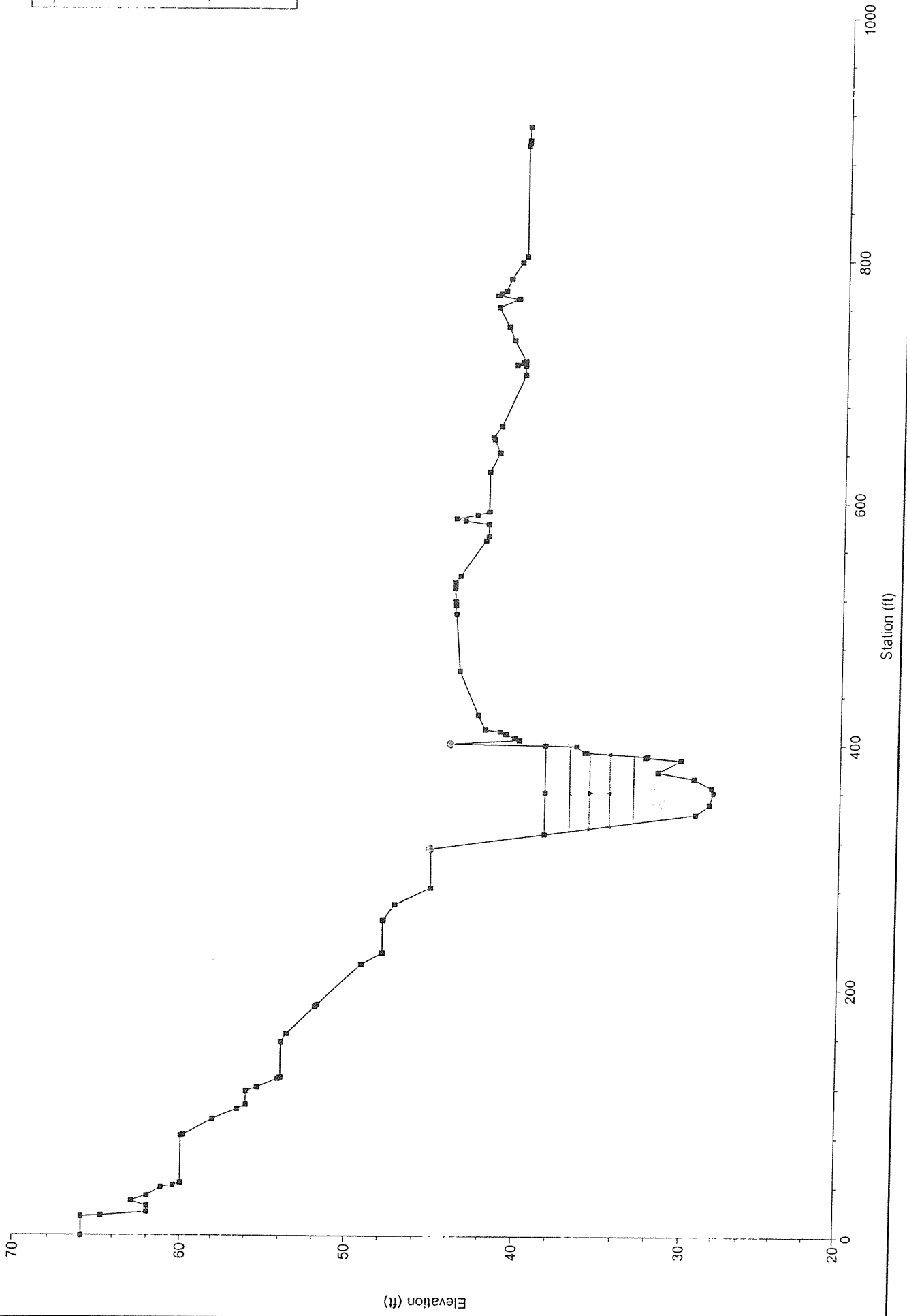

Legend	
WS 3000	—○—
WS 2500	-·-·-
WS 2000	·····
WS 1500	-△-
WS 1000	-○-
Ground	—■—
Levee	—■—
Bank Sta	○

Sycamore Creek Plan: EXISTING-WITH BRIDGES 3/10/2003  
 RS = 4451 BR QUINIENTOS BRIDGE (Q)

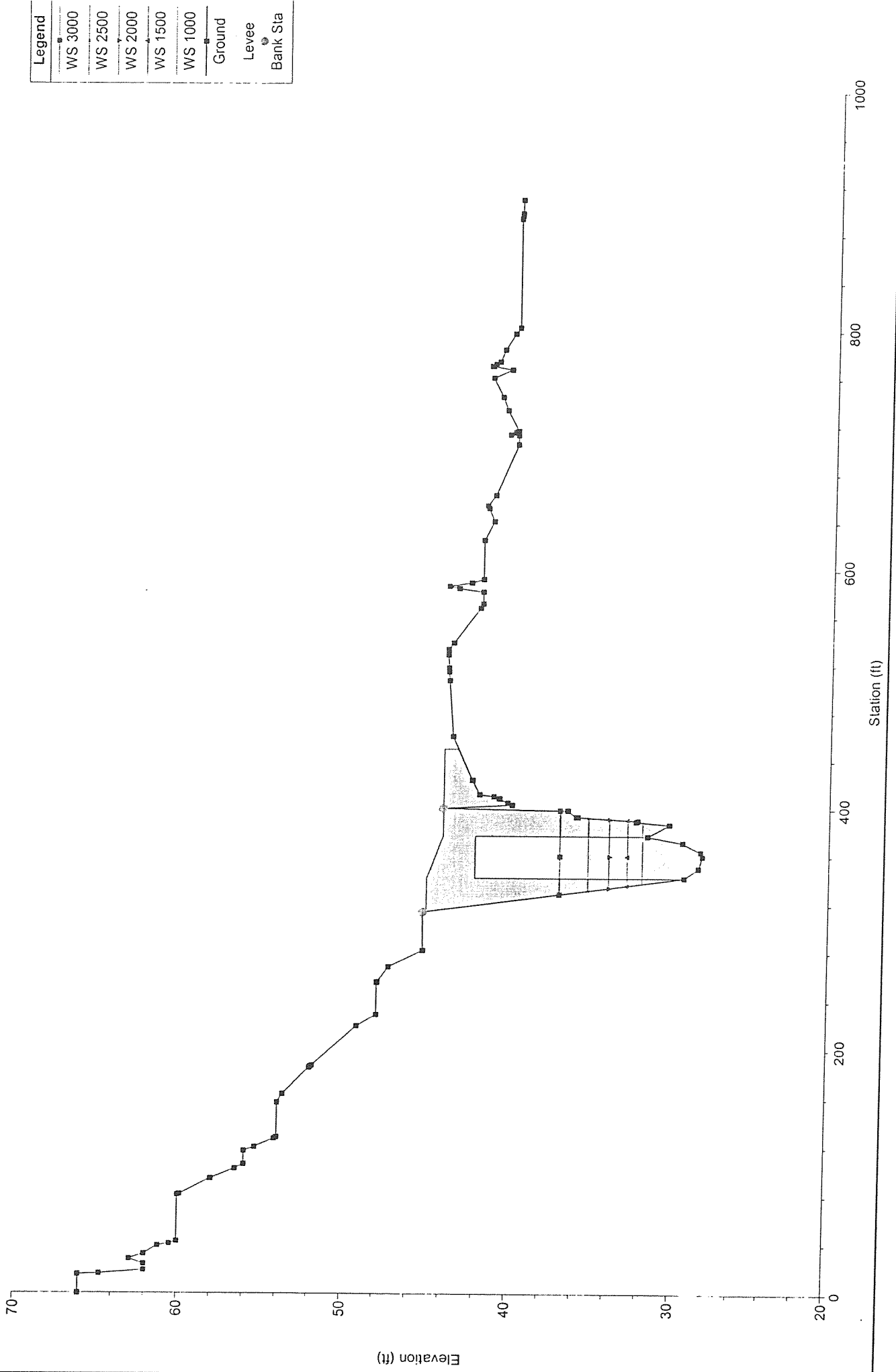

Sycamore Creek Plan: EXISTING-WITH BRIDGES 3/10/2003  
 RS = 4451 BR QUINIENTOS BRIDGE (Q)

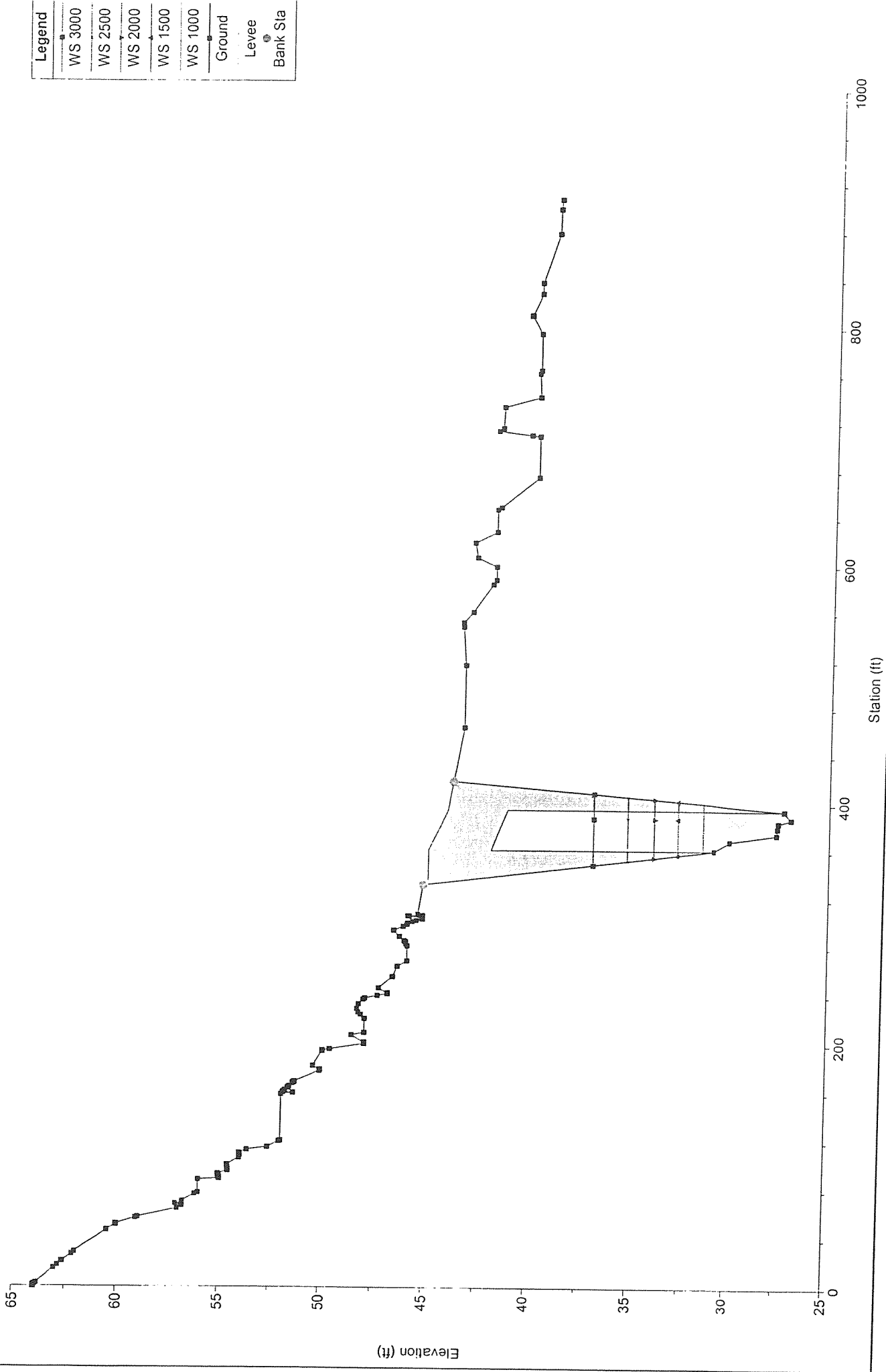

Sycamore Creek Plan: EXISTING-WITH BRIDGES 3/10/2003  
 RS = 4440.698 QUINIENTOS BRIDGE- DOWNSTREAM SIDE - RS 4440

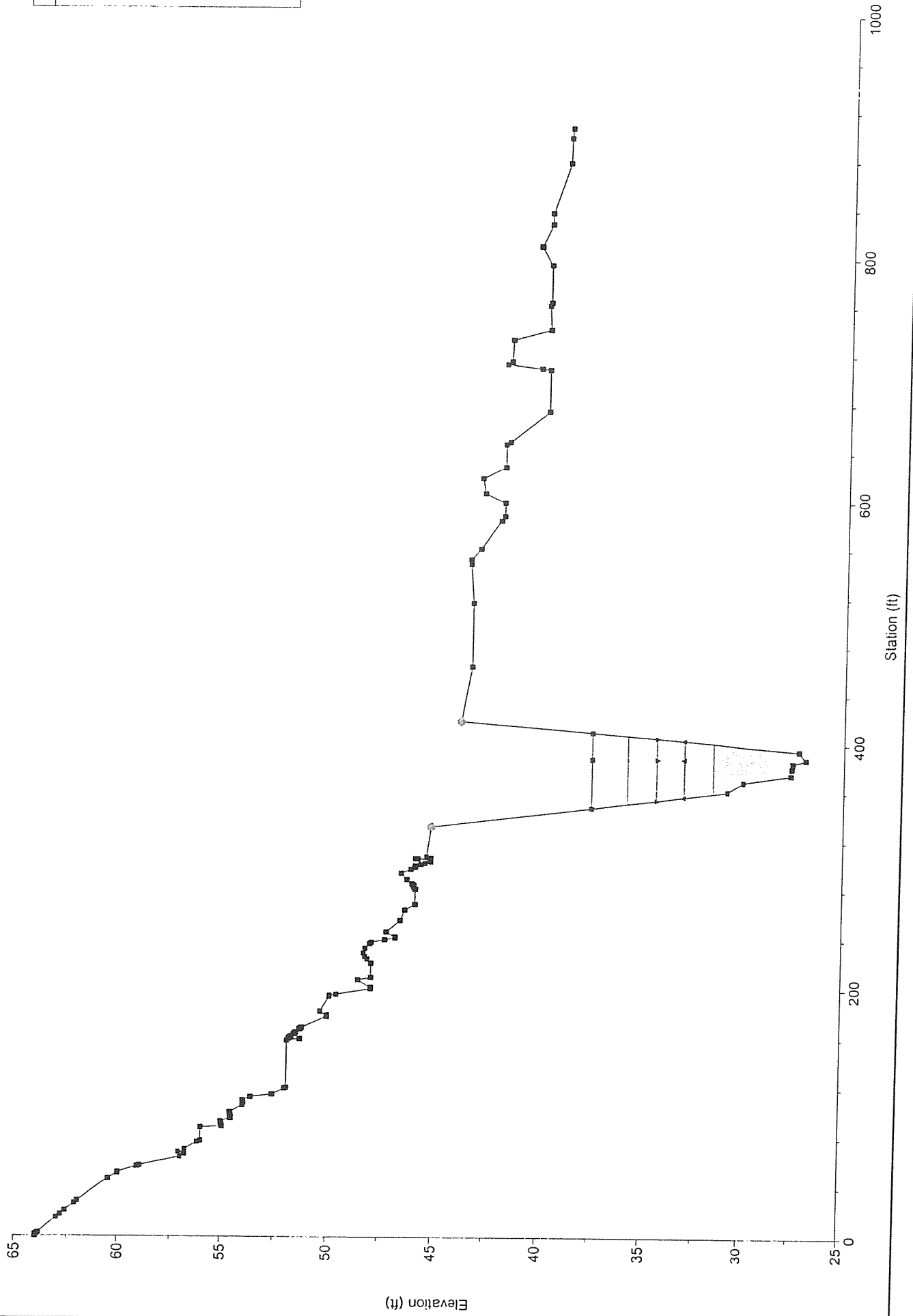

Legend	
WS 3000	—●—
WS 2500	—●—
WS 2000	—●—
WS 1500	—●—
WS 1000	—●—
Ground	.....
Levee	—●—
Bank Sta	—●—

Sycamore Creek Plan: EXISTING-WITH BRIDGES 3/10/2003  
 RS = 4322.648 BETWEEN CARPINTERIA AND QUINIENTOS #2 - RS 4322

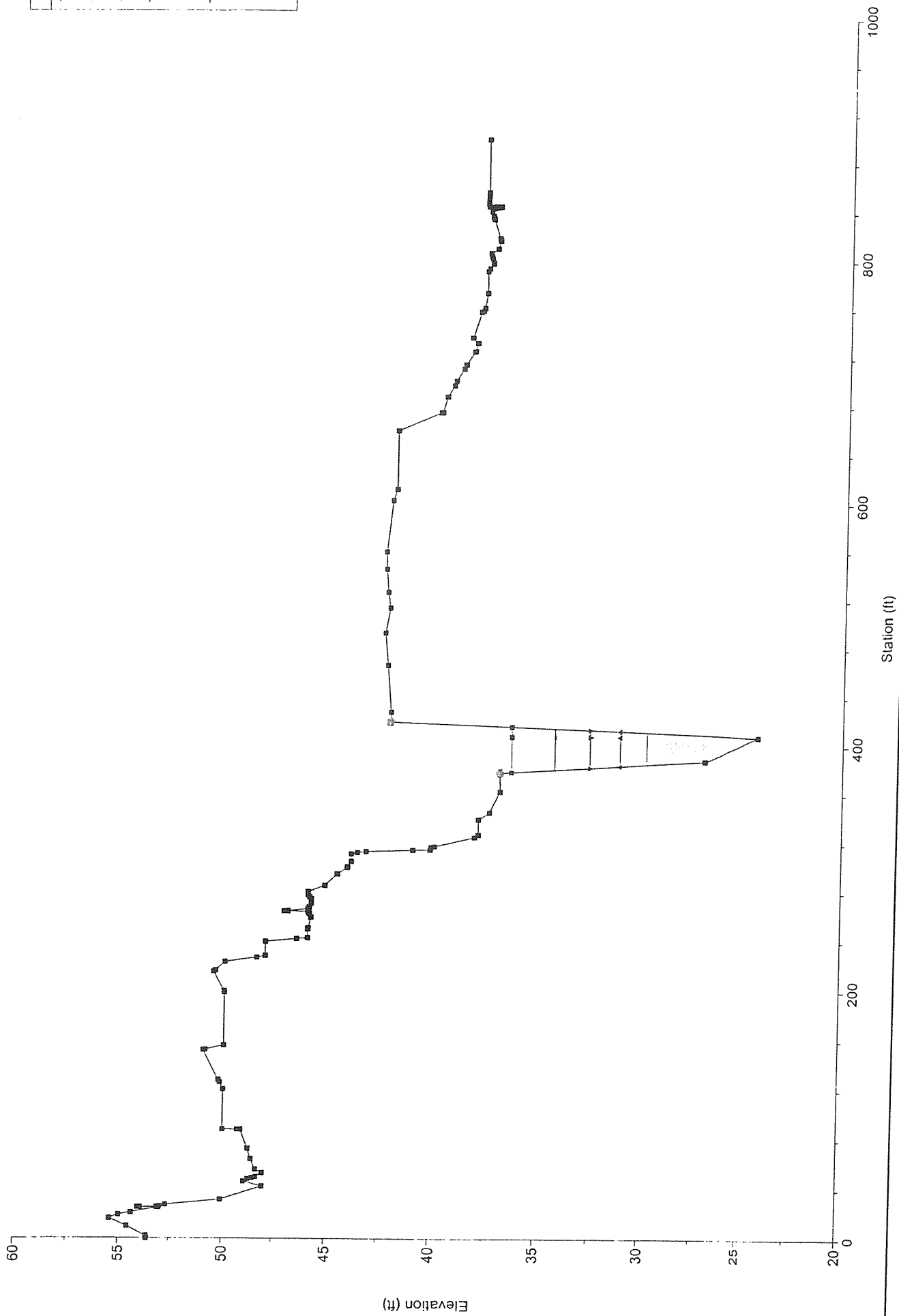

Legend	
WS 3000	—▲—
WS 2500	—▲—
WS 2000	—▲—
WS 1500	—▲—
WS 1000	—▲—
Ground	—■—
Levee	—▲—
Bank Sta	—●—

Sycamore Creek Plan: EXISTING-WITH BRIDGES 3/10/2003  
 RS = 4018.188 BETWEEN CARPINTERIA AND QUINIENTOS #1 - RS 4018

Legend	
—■—	WS 3000
—■—	WS 2500
—■—	WS 2000
—■—	WS 1500
—■—	WS 1000
—○—	Ground
●	Levee
○	Bank Sta

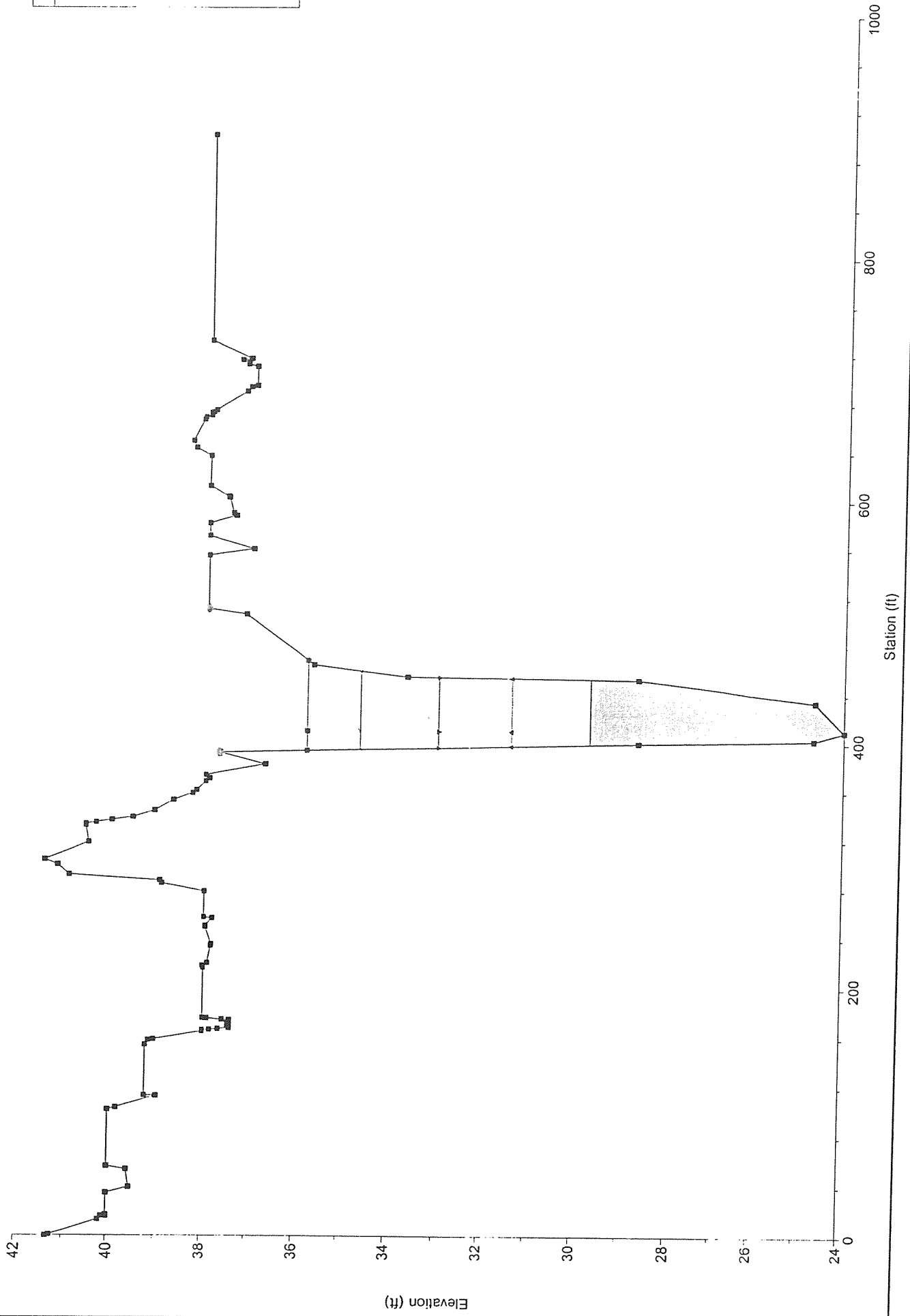



Sycamore Creek Plan: EXISTING-WITH BRIDGES 3/10/2003  
 RS = 3953.405 CARPINTERIA BRIDGE - UPSTREAM SIDE - RS 3953

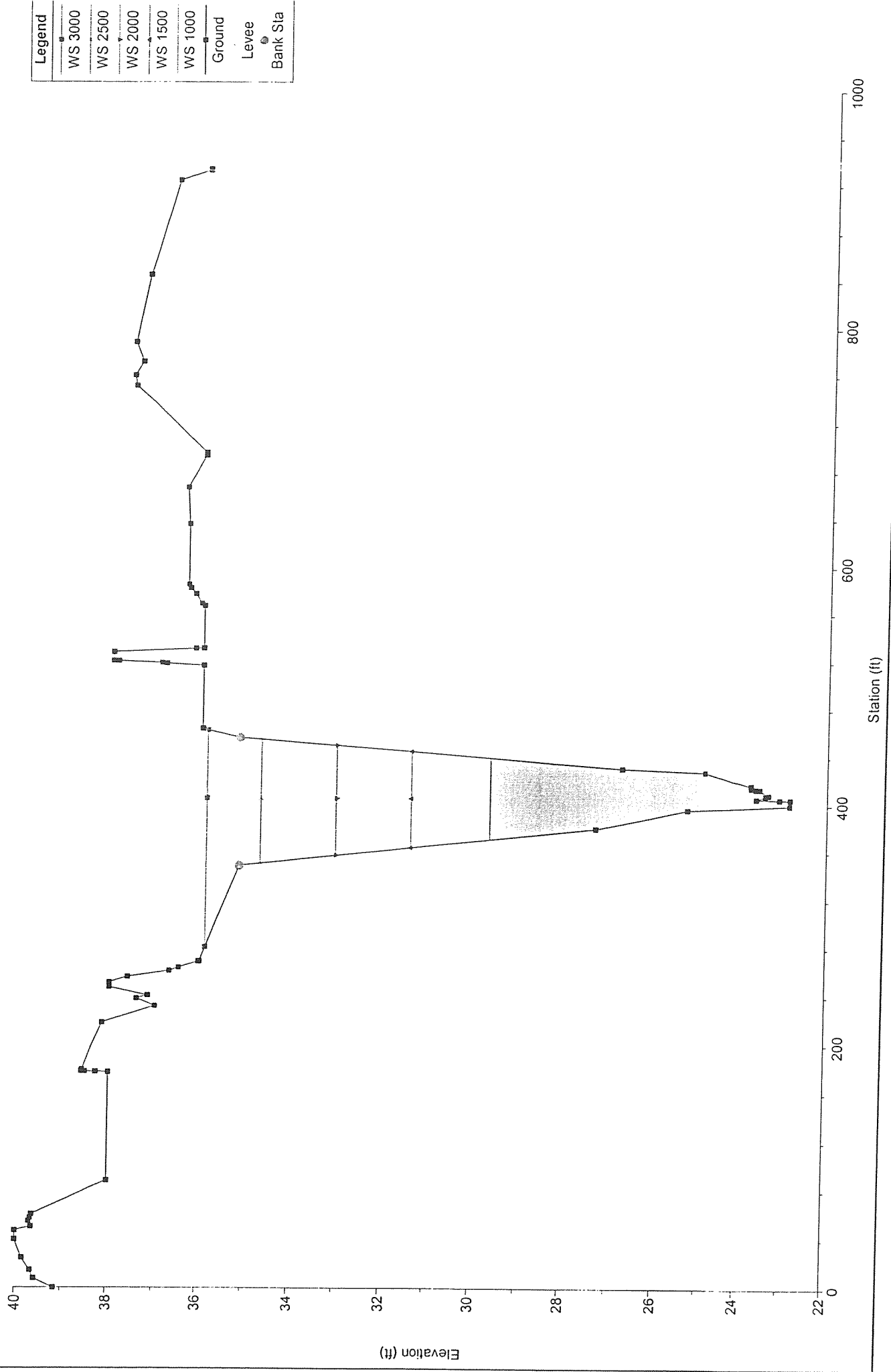

Sycamore Creek Plan: EXISTING-WITH BRIDGES 3/10/2003  
 RS = 3920 BR CARPINTERIA BRIDGE (N)

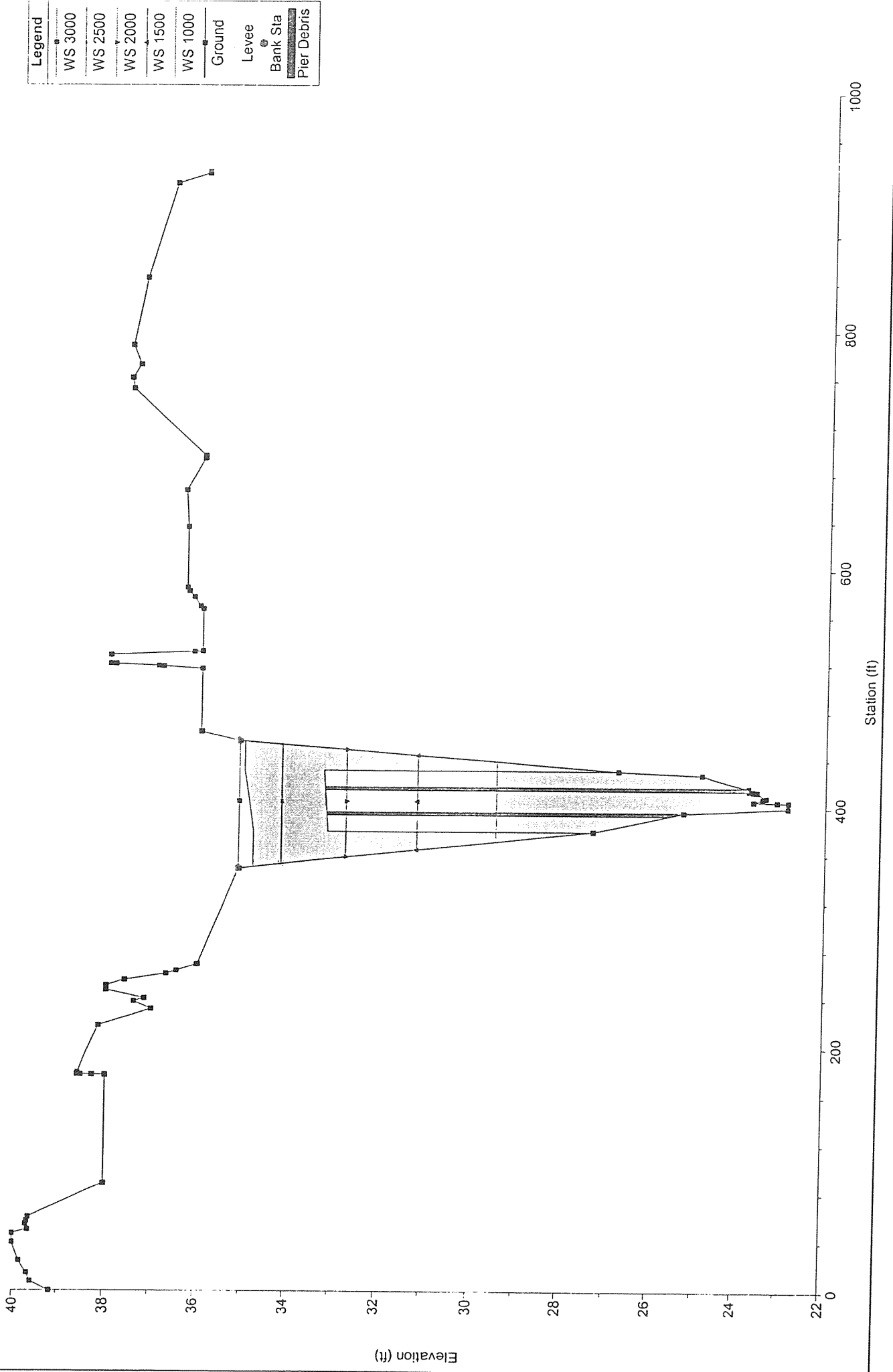

Sycamore Creek Plan: EXISTING-WITH BRIDGES 3/10/2003  
 RS = 3920 BR CARPINTERIA BRIDGE (N)

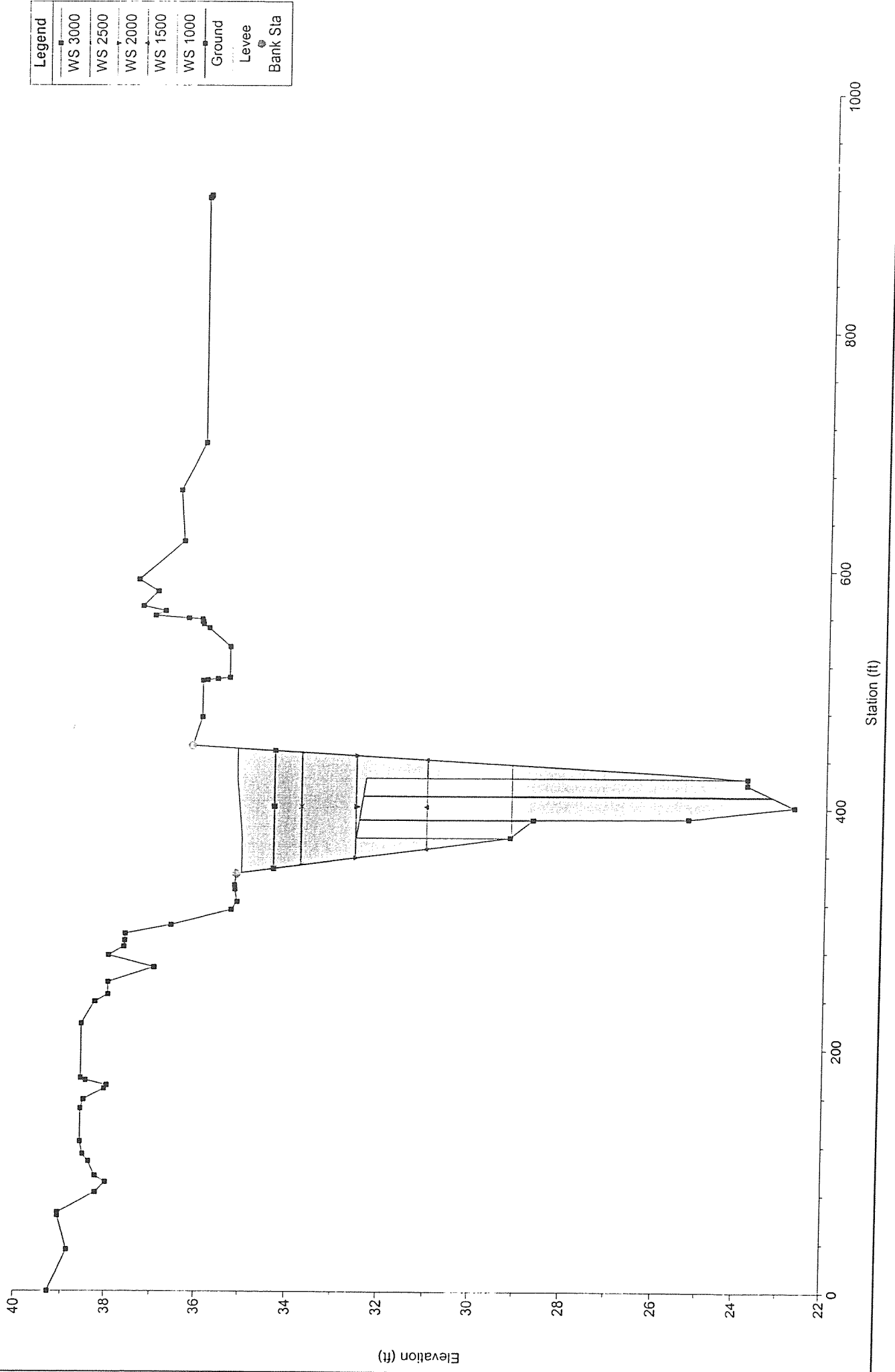

Sycamore Creek Plan: EXISTING-WITH BRIDGES 3/10/2003  
 RS = 3914.370 CARRPINTERIA BRIDGE - DOWNSTREAM SIDE - RS 3914

Legend	
—■—	WS 3000
—■—	WS 2500
—■—	WS 2000
—■—	WS 1500
—■—	WS 1000
—	Ground
—	Levee
—●—	Bank Sta

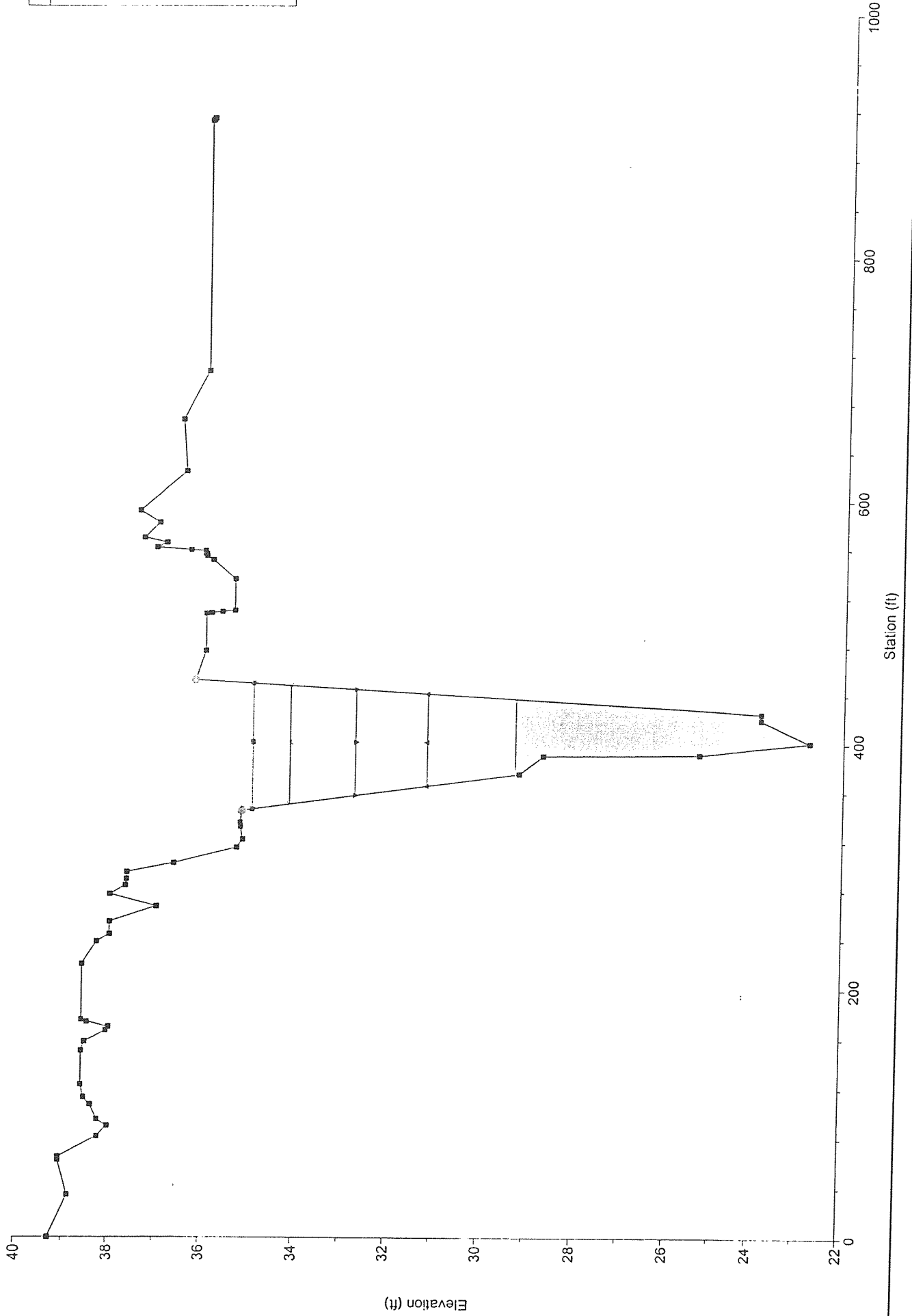

Sycamore Creek Plan: EXISTING-WITH BRIDGES 3/10/2003  
 RS = 3837.489 BETWEEN CACIQUE AND CARPINTERIA #2 - RS 3837

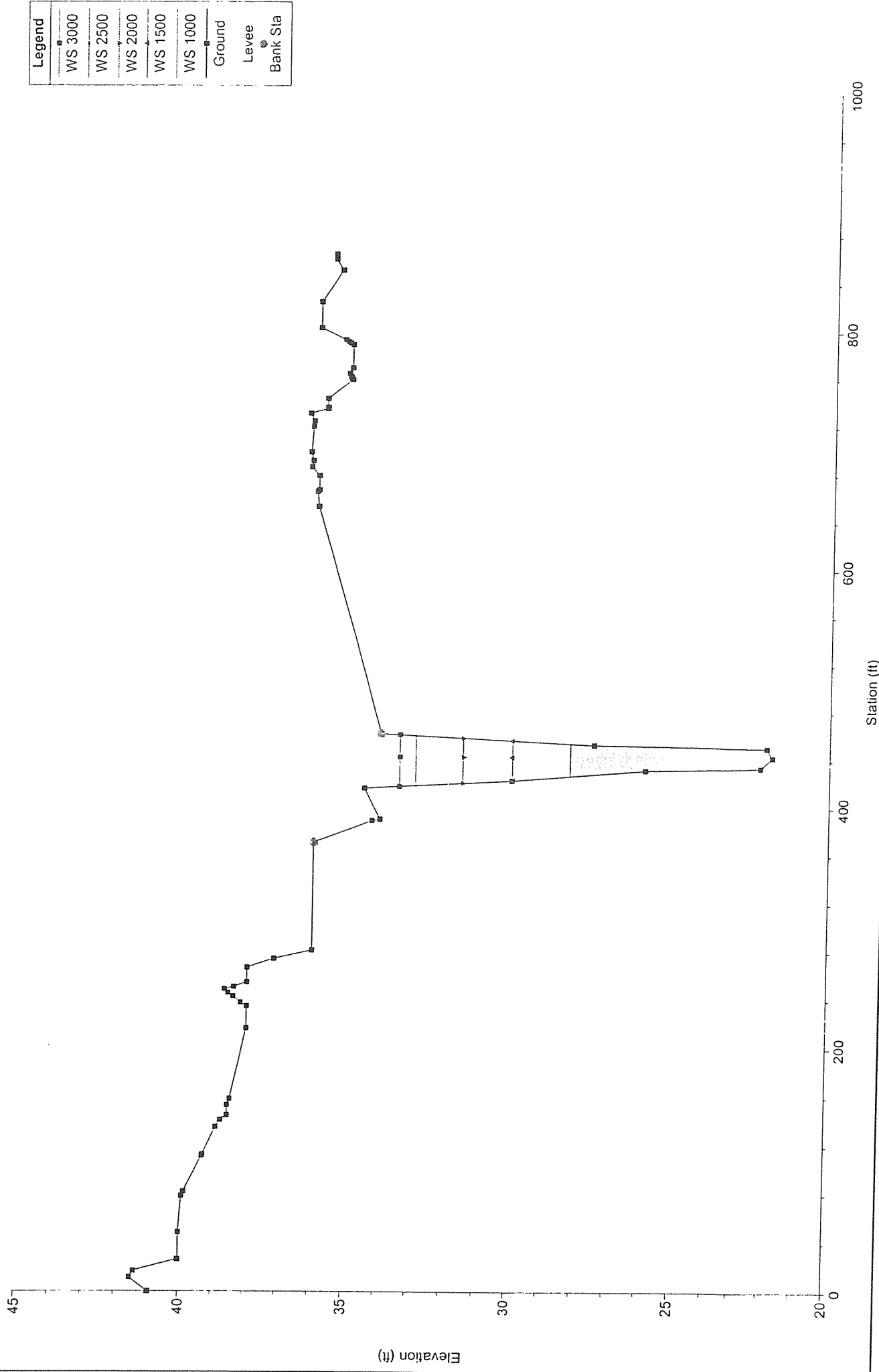

Legend	
—■—	WS 3000
- - -	WS 2500
- · - · -	WS 2000
—	WS 1500
· · ·	WS 1000
—	Ground
- - -	Levee
●	Bank Sta

Sycamore Creek Plan: EXISTING-WITH BRIDGES 3/10/2003  
 RS = 3792.019 BETWEEN CACIQUE AND CARPINTERIA #1 - RS 3792

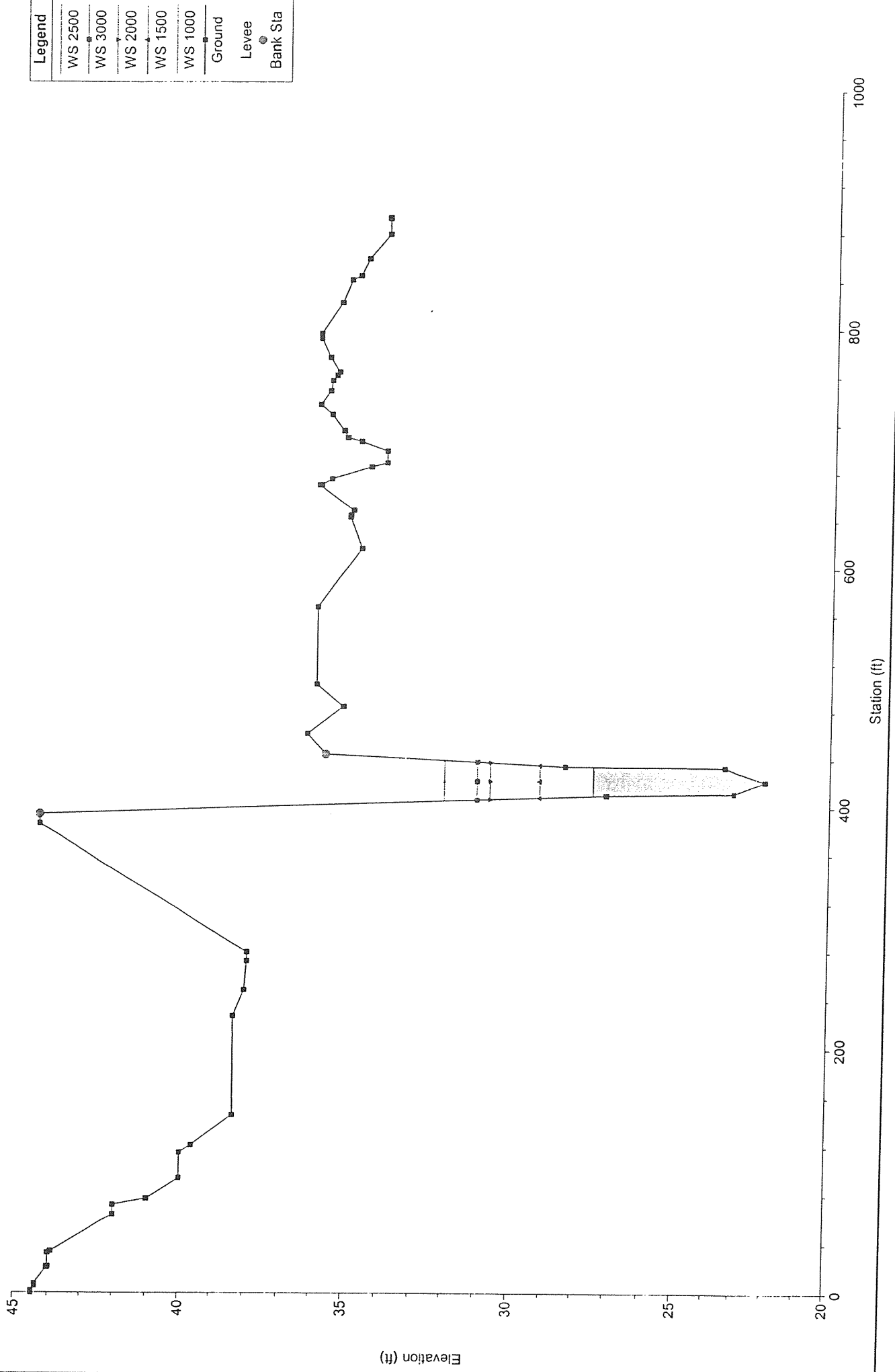

Legend	
WS 2500	□
WS 3000	□
WS 2000	□
WS 1500	□
WS 1000	□
Ground	—
Levee	- - -
Bank Sta	●



Sycamore Creek Plan: EXISTING-WITH BRIDGES 3/10/2003  
 RS = 3278 BR CACIQUE BRIDGE (H)

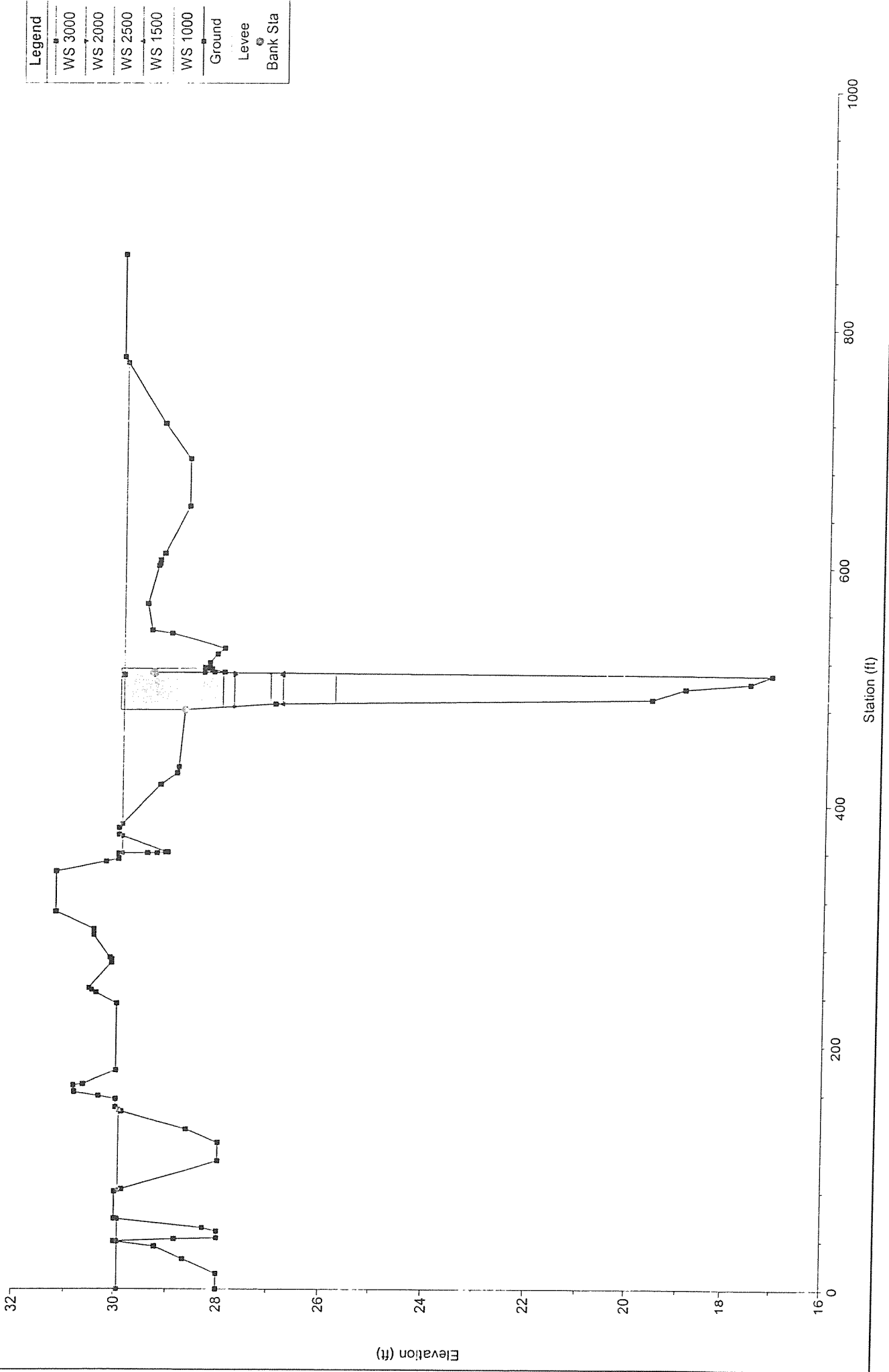

Legend	
WS 3000	—
WS 2000	—
WS 2500	—
WS 1500	—
WS 1000	—
Ground	—
Levee	■
Bank Sta	○



Sycamore Creek Plan: EXISTING-WITH BRIDGES 3/10/2003  
 RS = 3278 BR CACIQUE BRIDGE (H)

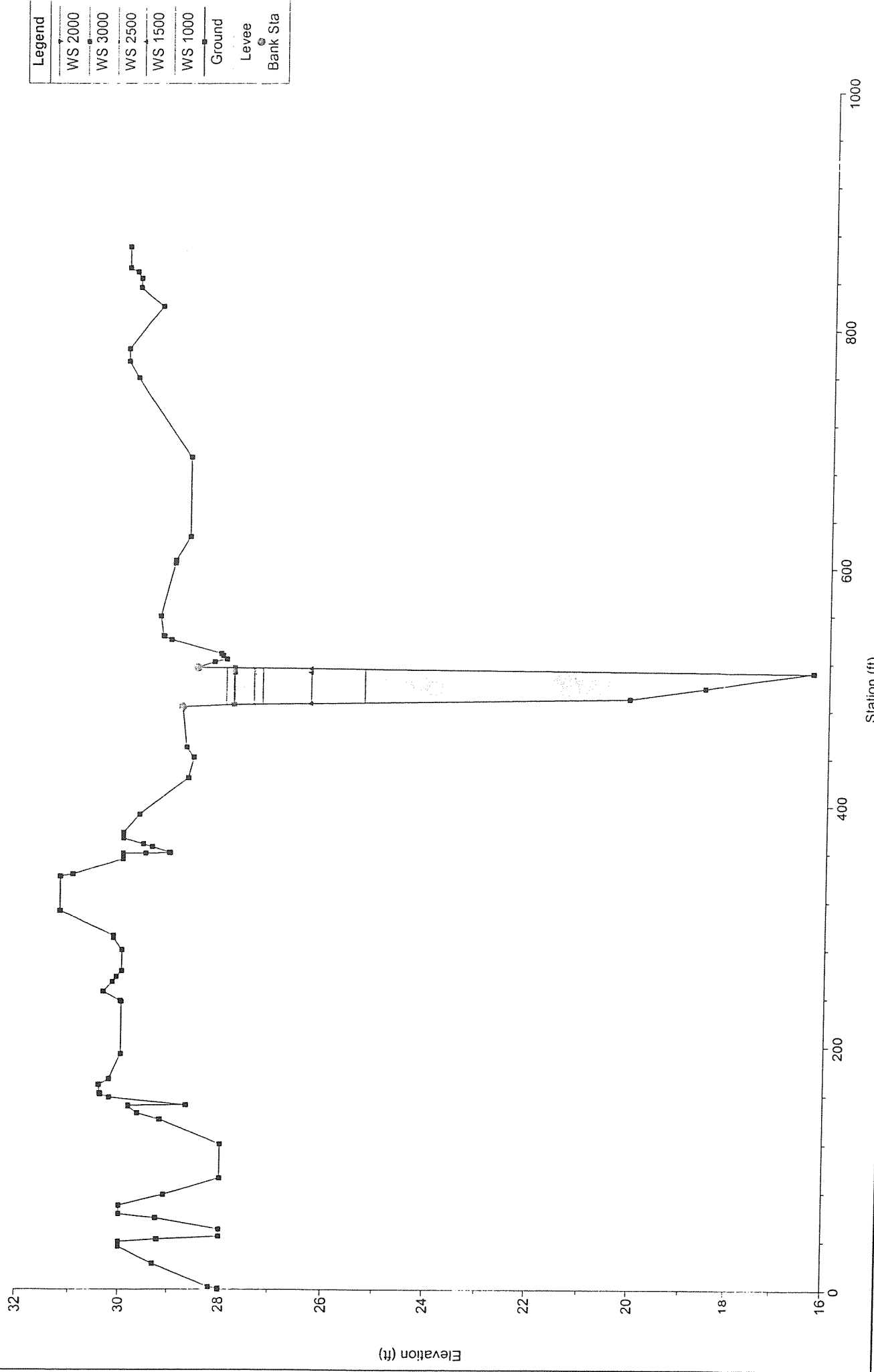

Legend	
WS 2000	—
WS 3000	—
WS 2500	—
WS 1500	—
WS 1000	—
Ground	—
Levee	—
Bank Sta	—



Sycamore Creek Plan: EXISTING-WITH BRIDGES 3/10/2003  
 RS = 3198.905 BETWEEN INDIO MUERTO AND CACIQUE #2 - RS 3198

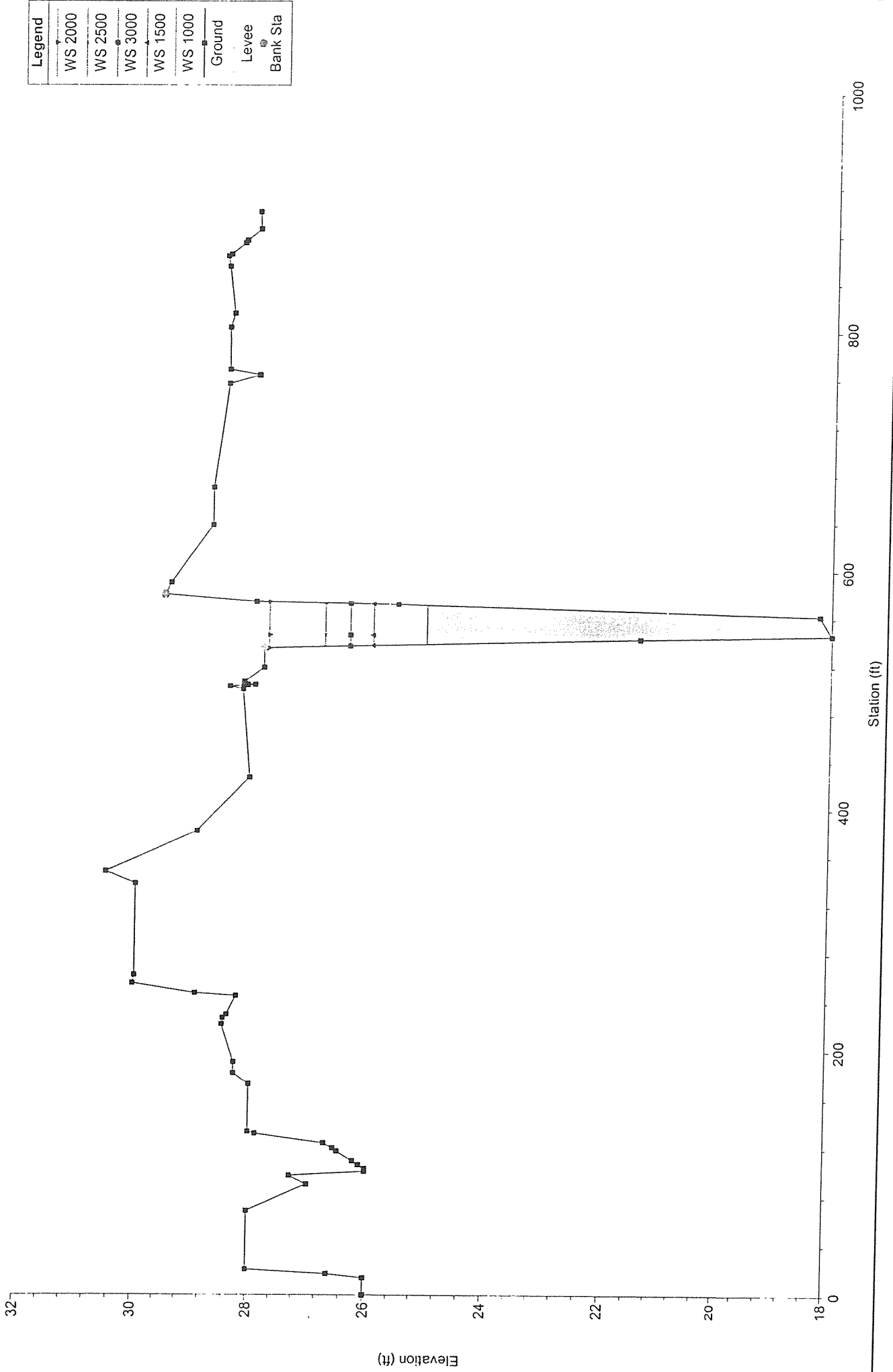

Sycamore Creek Plan: EXISTING-WITH BRIDGES 3/10/2003  
 RS = 2805.371 BETWEEN INDIO MUERTO AND CACIQUE #1 - RS 2805

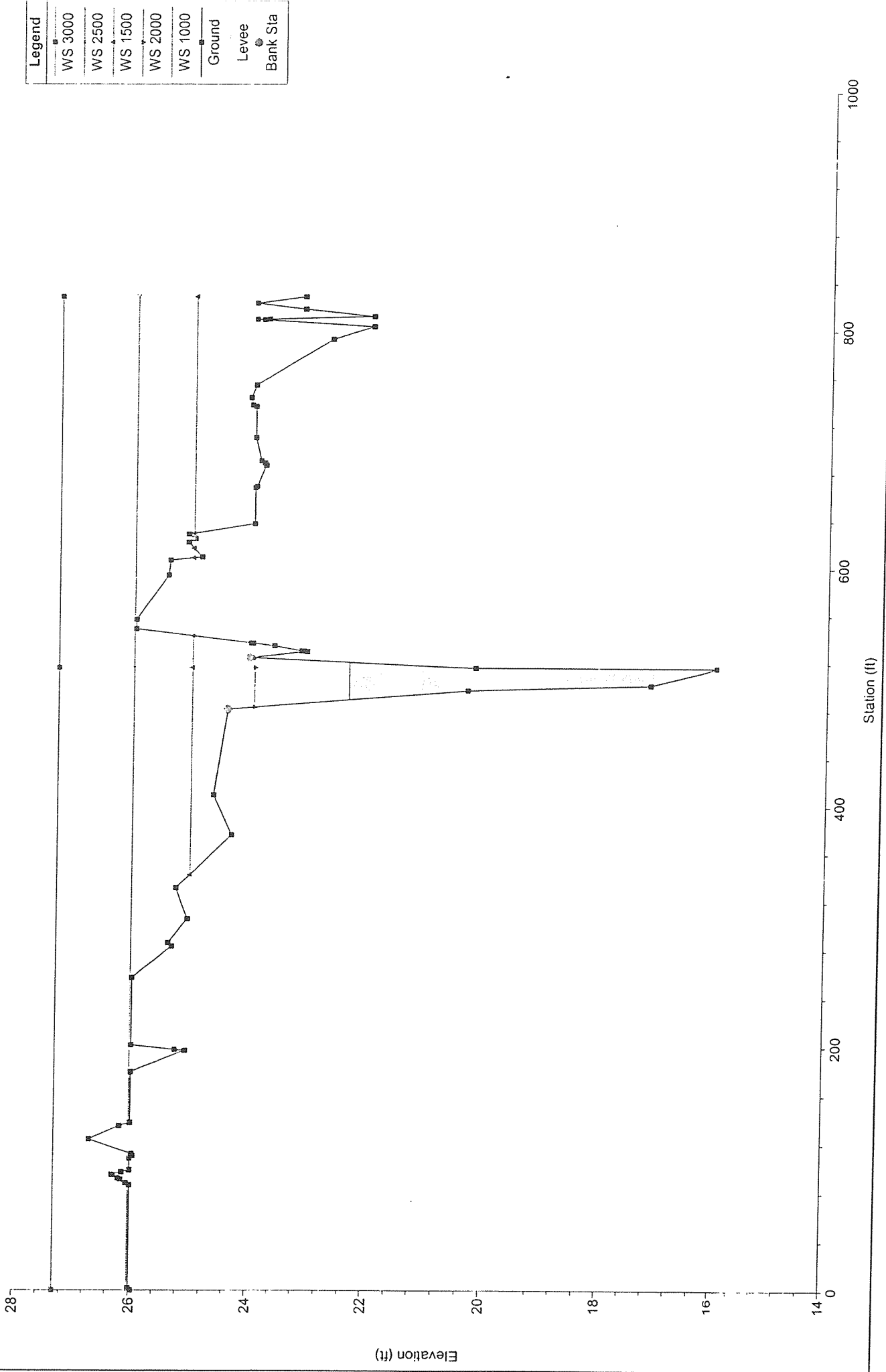

Legend	
■	WS 3000
■	WS 2500
■	WS 1500
■	WS 2000
■	WS 1000
—	Ground
○	Levee
●	Bank Sta

Sycamore Creek Plan: EXISTING-WITH BRIDGES 3/10/2003  
 RS = 2773.736 INDIO MUERTO BRIDGE- UPSTREAM SIDE - RS 2773

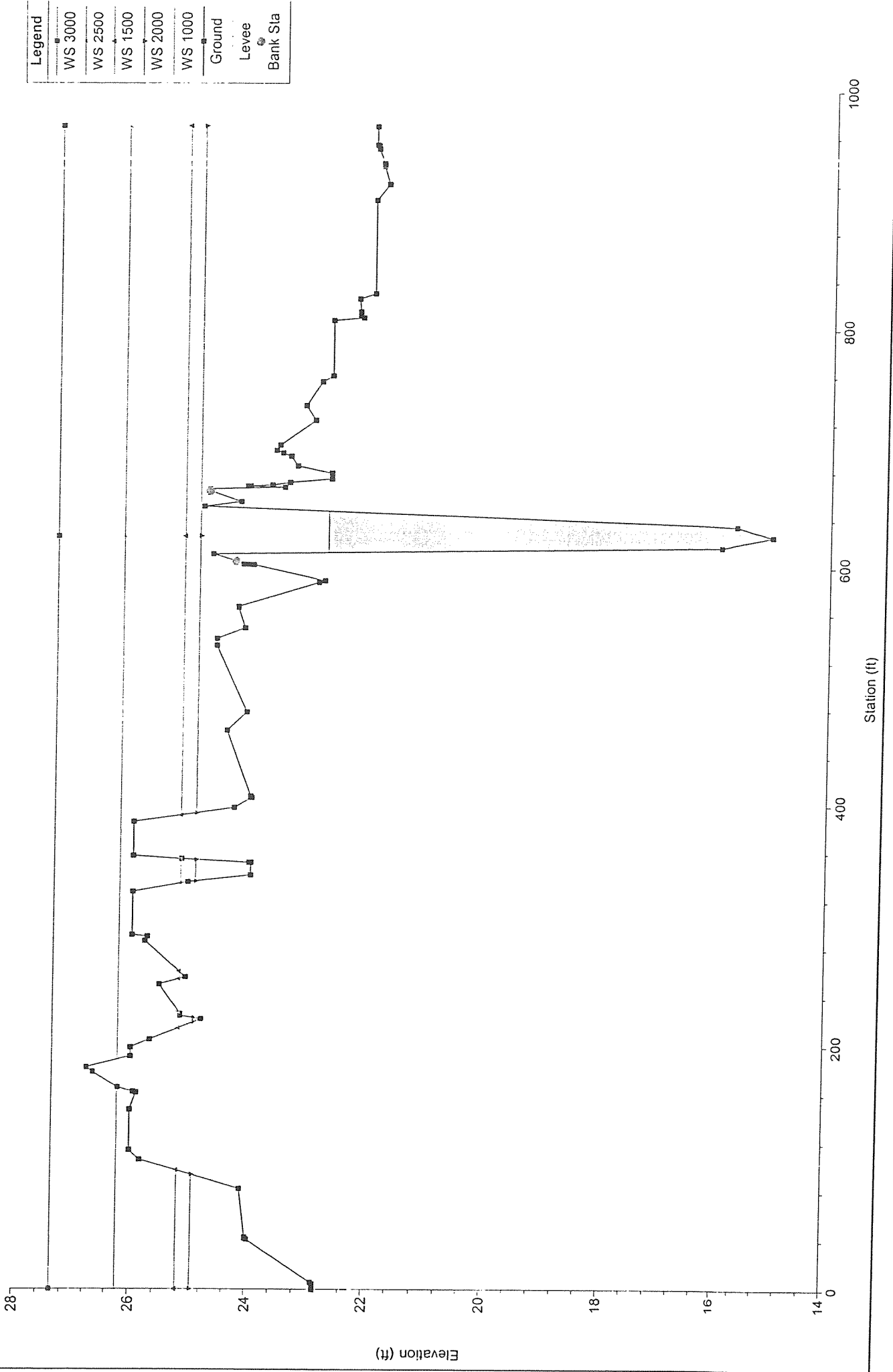

Sycamore Creek Plan: EXISTING-WITH BRIDGES 3/10/2003  
 RS = 2732 BR INDIO MUERTO BRIDGE (I)

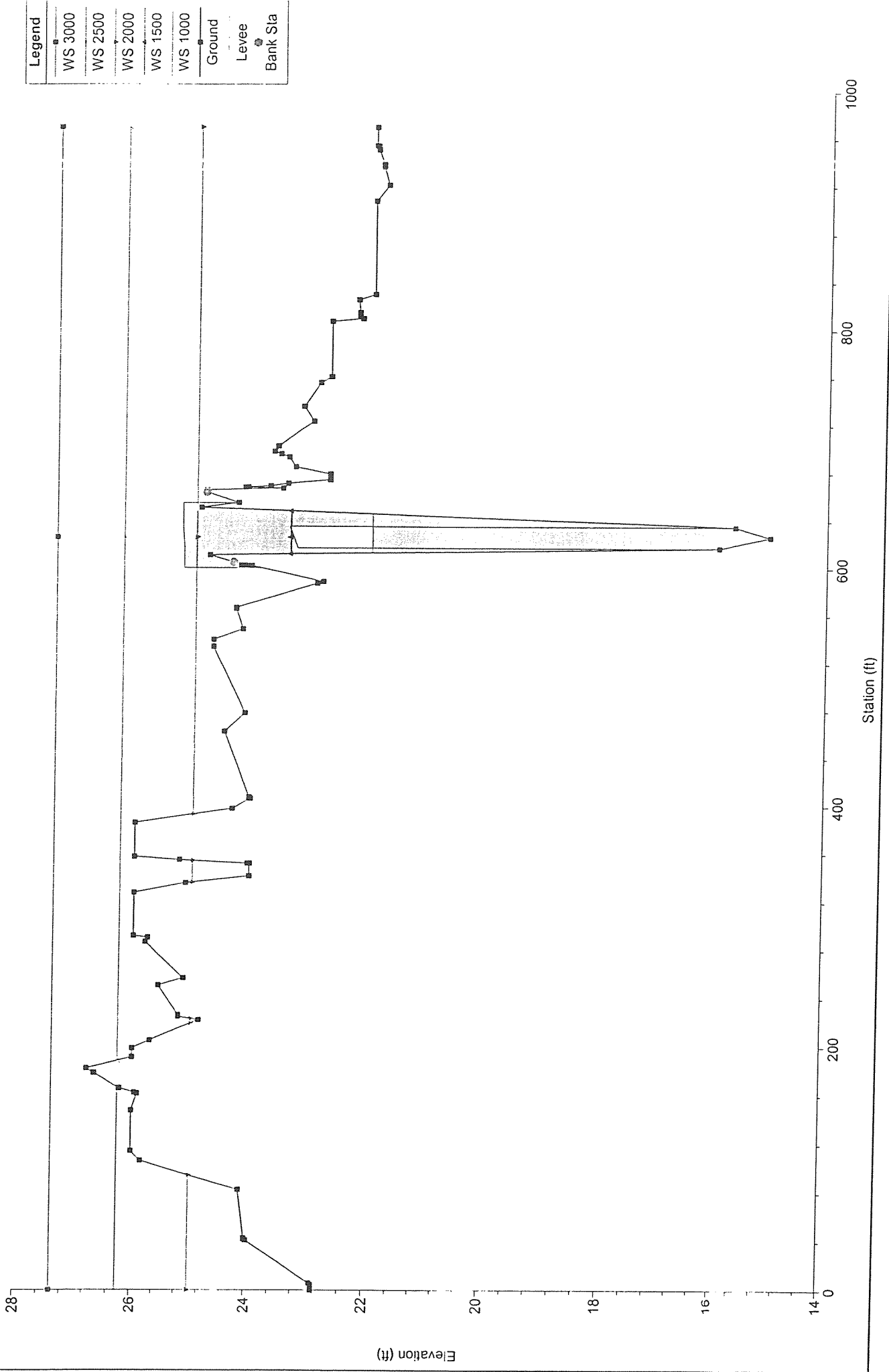

Sycamore Creek Plan: EXISTING-WITH BRIDGES 3/10/2003  
 RS = 2732 BR INDIO MUERTO BRIDGE (I)

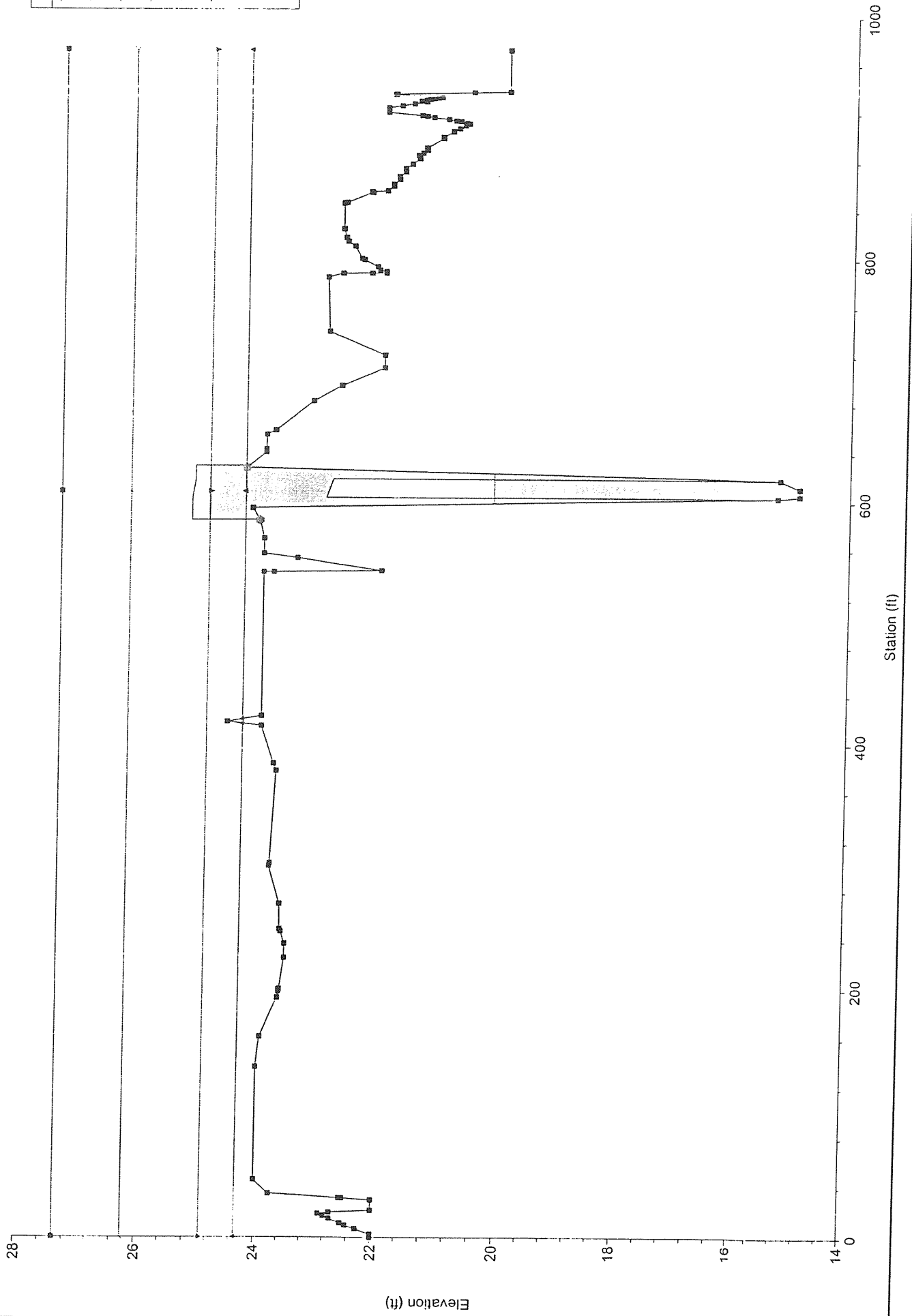

Legend	
■	WS 3000
■	WS 2500
■	WS 2000
■	WS 1500
■	WS 1000
—	Ground
—	Levee
—	Bank Sta





Sycamore Creek Plan: EXISTING-WITH BRIDGES 3/10/2003  
 RS = 2529.295 BETWEEN PUNTA GORDA AND INDIO MUERTO #2 - RS 2529

Legend	
—■—	WS 3000
—■—	WS 2500
—■—	WS 2000
—■—	WS 1500
—■—	WS 1000
—	Ground
—	Levee
●	Bank Sta

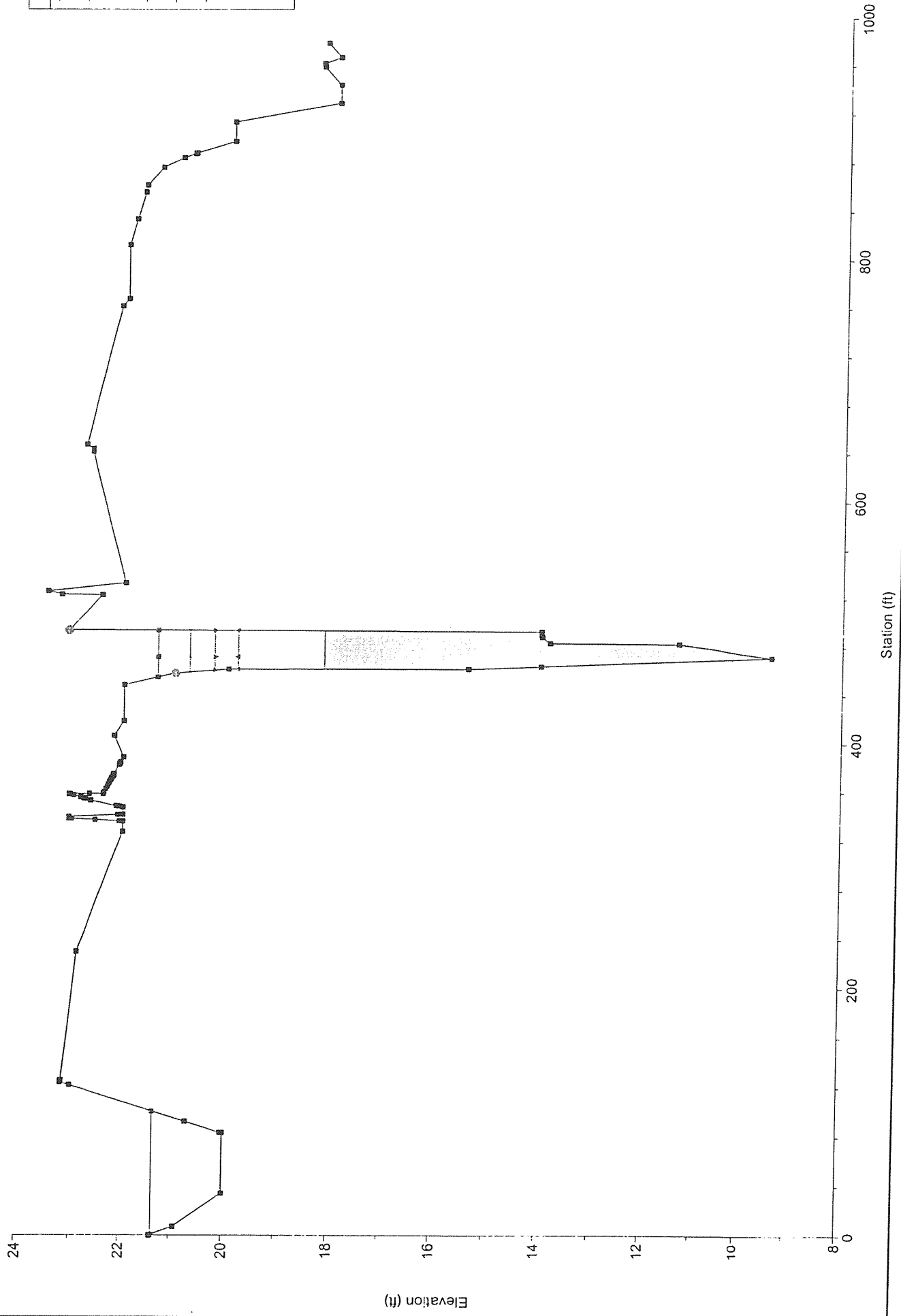

Sycamore Creek Plan: EXISTING-WITH BRIDGES 3/10/2003  
 RS = 2294.216 BETWEEN PUNTA GORDA AND INDIO MUERTO #1 - RS 2294

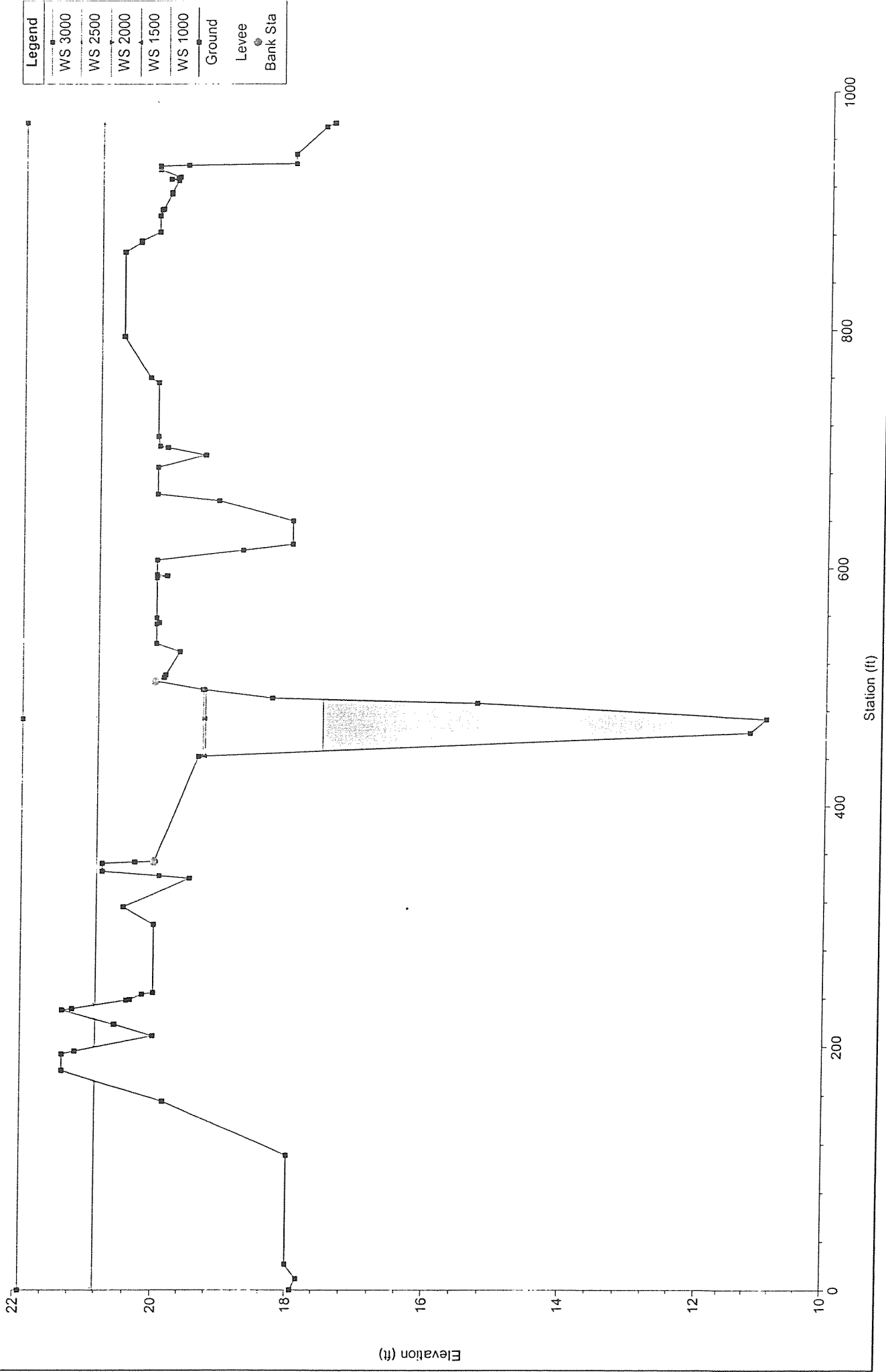

Legend	
■	WS 3000
■	WS 2500
■	WS 2000
■	WS 1500
■	WS 1000
---	Ground
—	Levee
●	Bank Sta

Sycamore Creek Plan: EXISTING-WITH BRIDGES 3/10/2003  
 RS = 2181.047 PUNTA GORDA BRIDGE - UPSTREAM SIDE - RS 2181

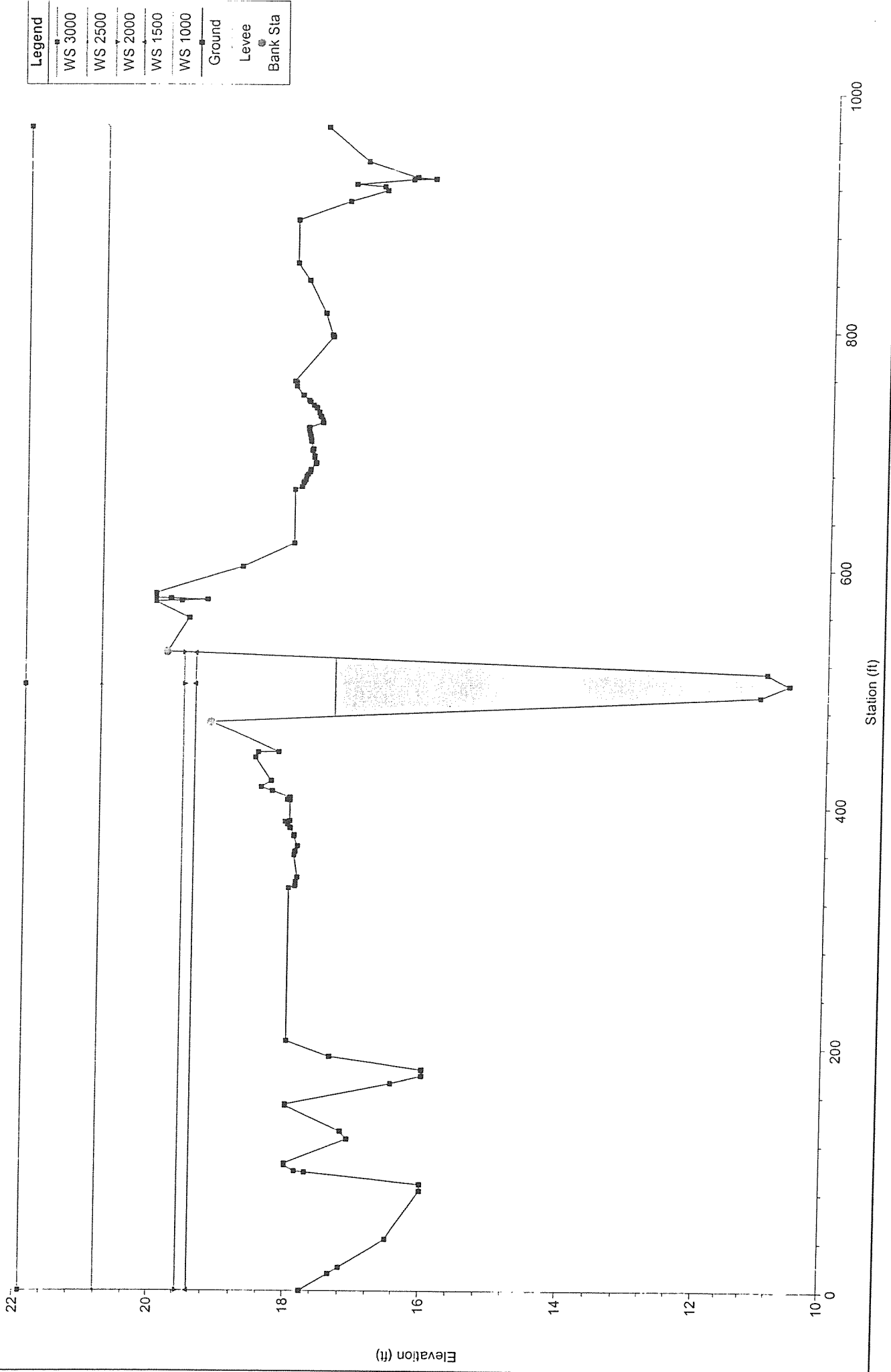

Legend	
—■—	WS 3000
—●—	WS 2500
—▲—	WS 2000
—▼—	WS 1500
—◆—	WS 1000
—	Ground
- - -	Levee
○	Bank Sta



Sycamore Creek Plan: EXISTING-WITH BRIDGES 3/10/2003  
 RS = 2151 BR PUNTA GORDA BRIDGE (J)

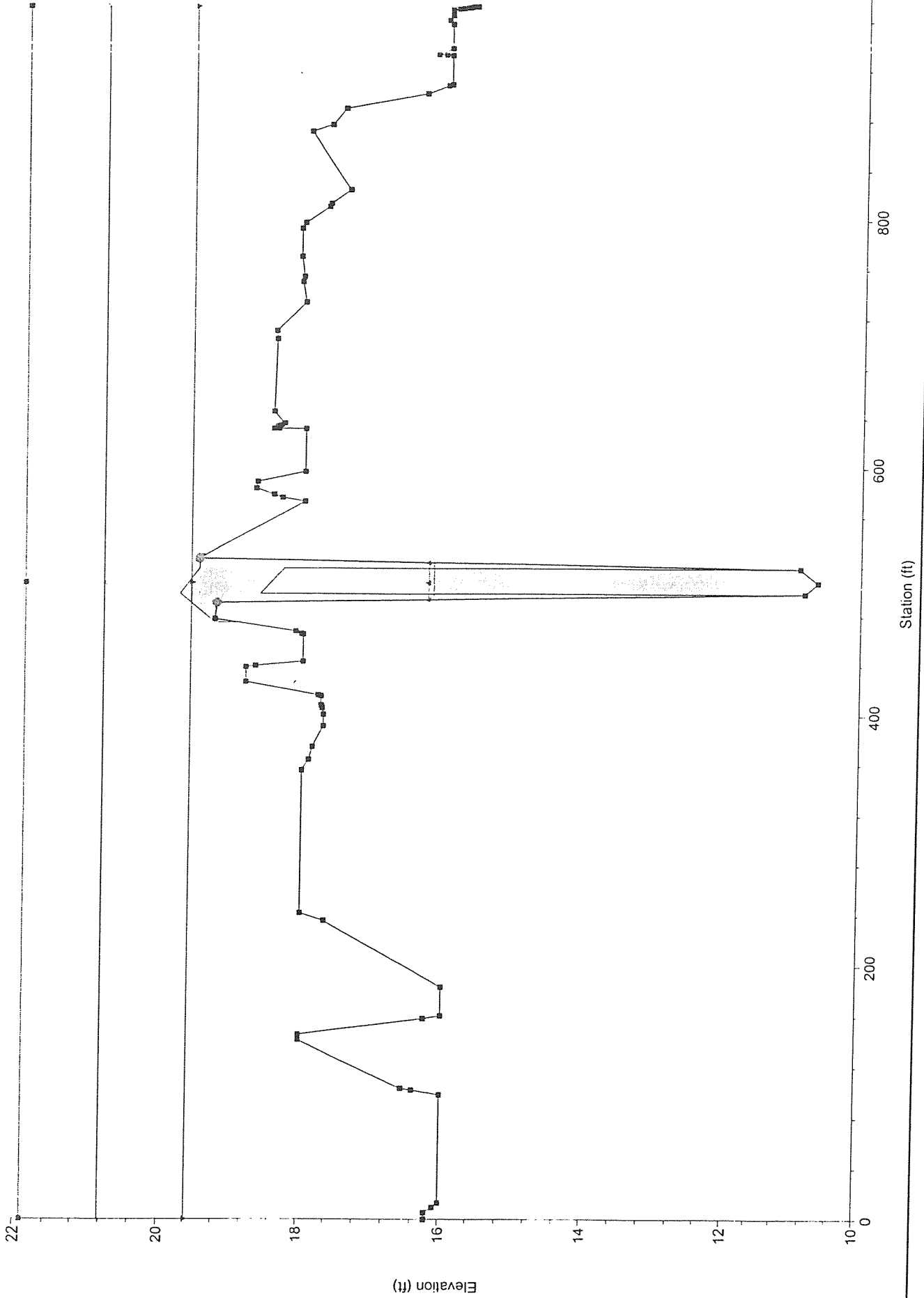

Legend	
WS 3000	—
WS 2500	—
WS 2000	—
WS 1500	—
WS 1000	—
Ground	—
Levee	—
Bank Sta	—

Sycamore Creek Plan: EXISTING-WITH BRIDGES 3/10/2003  
 RS = 2144.783 PUNTA GORDA BRIDGE - DOWNSTREAM SIDE - RS 2144

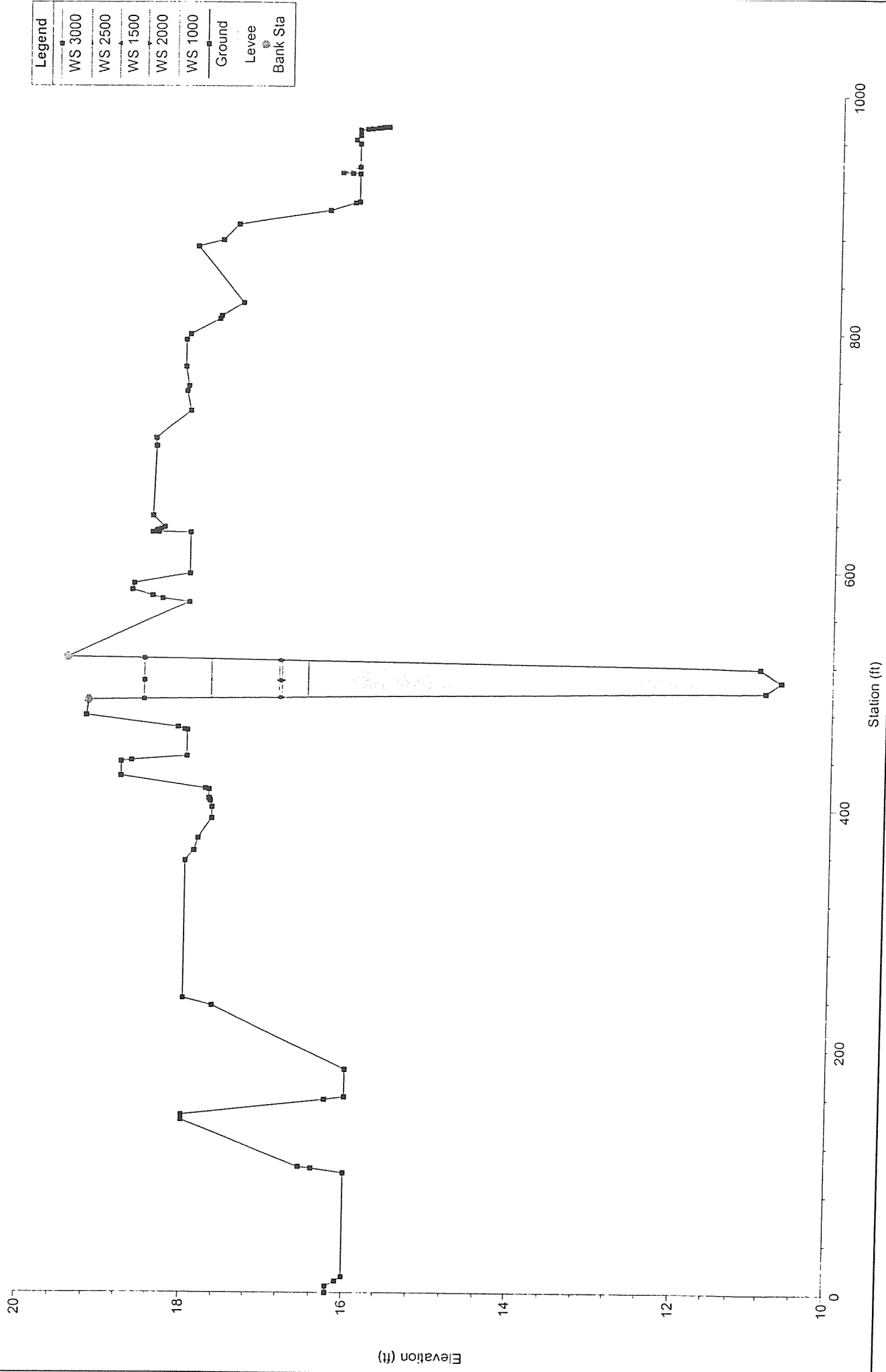

Legend	
WS 3000	.....
WS 2500	- . - . - .
WS 1500	-----
WS 2000	—————
WS 1000	—————
Ground	—————
Levee	-----
Bank Sta	⊙

Sycamore Creek Plan: EXISTING-WITH BRIDGES 3/10/2003  
 RS = 2051.565 BETWEEN 101 AND PUNTA GORDA - RS 2051

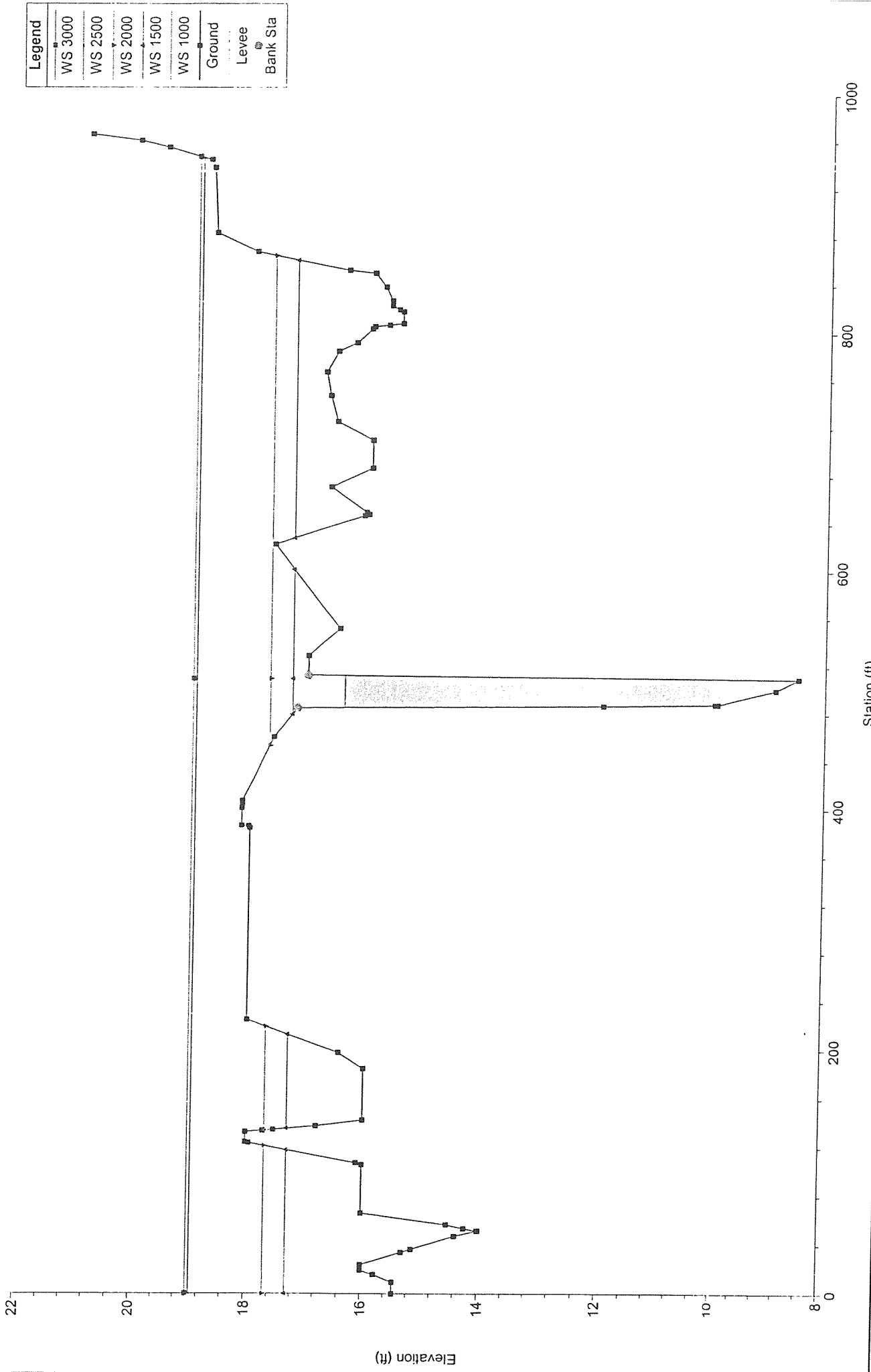

Legend	
—	WS 3000
—	WS 2500
—	WS 2000
—	WS 1500
—	WS 1000
—	Ground
—	Levee
—	Bank Sta

Sycamore Creek Plan: EXISTING-WITH BRIDGES 3/10/2003  
 RS = 1831.350 101 BRIDGE - UPSTREAM SIDE - RS 1831

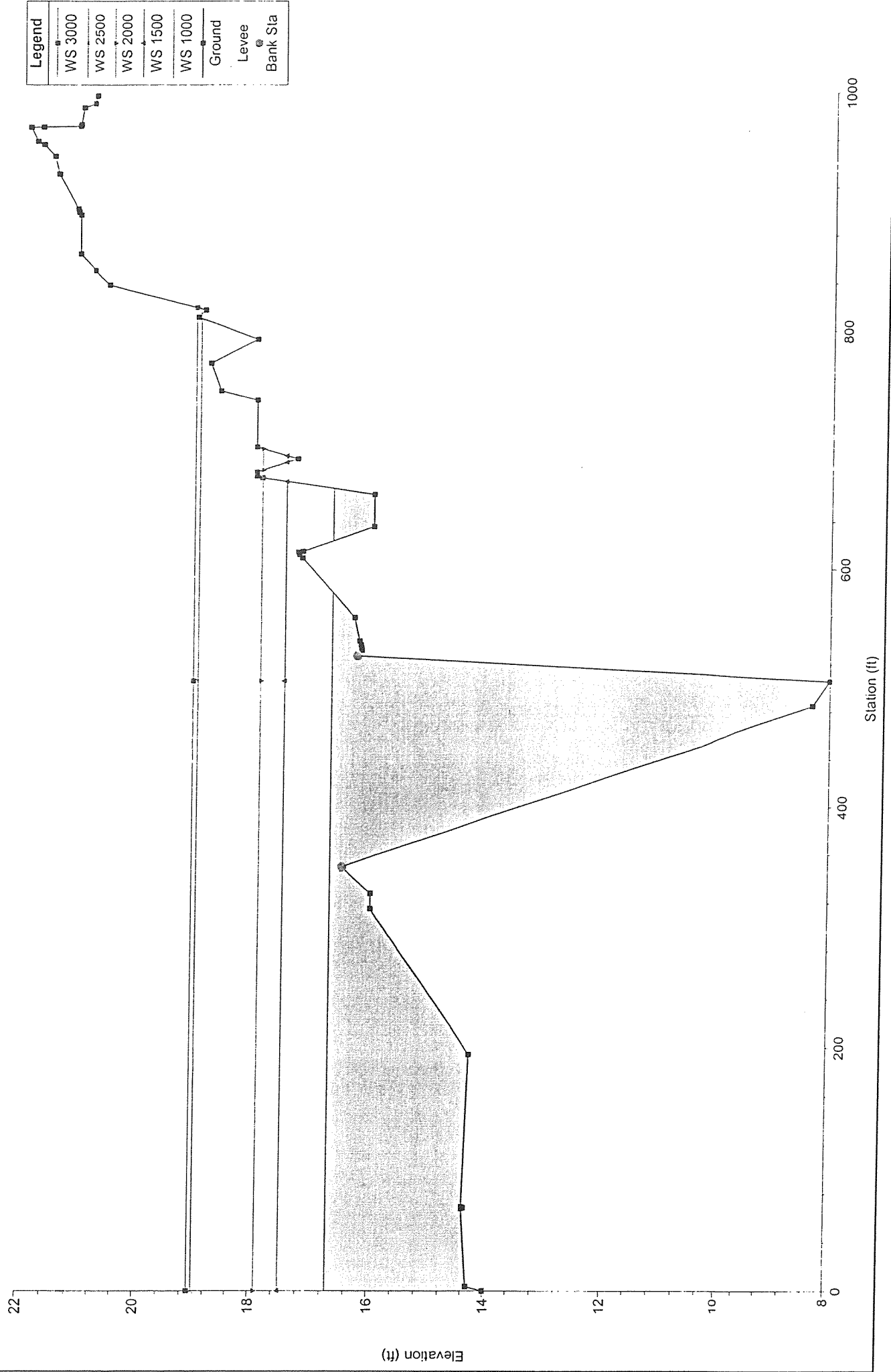

Legend	
—	WS 3000
—	WS 2500
—	WS 2000
—	WS 1500
—	WS 1000
—	Ground
—	Levee
●	Bank Sta





Sycamore Creek Plan: EXISTING-WITH BRIDGES 3/10/2003  
 RS = 1730 BR 101 BRIDGE (A)

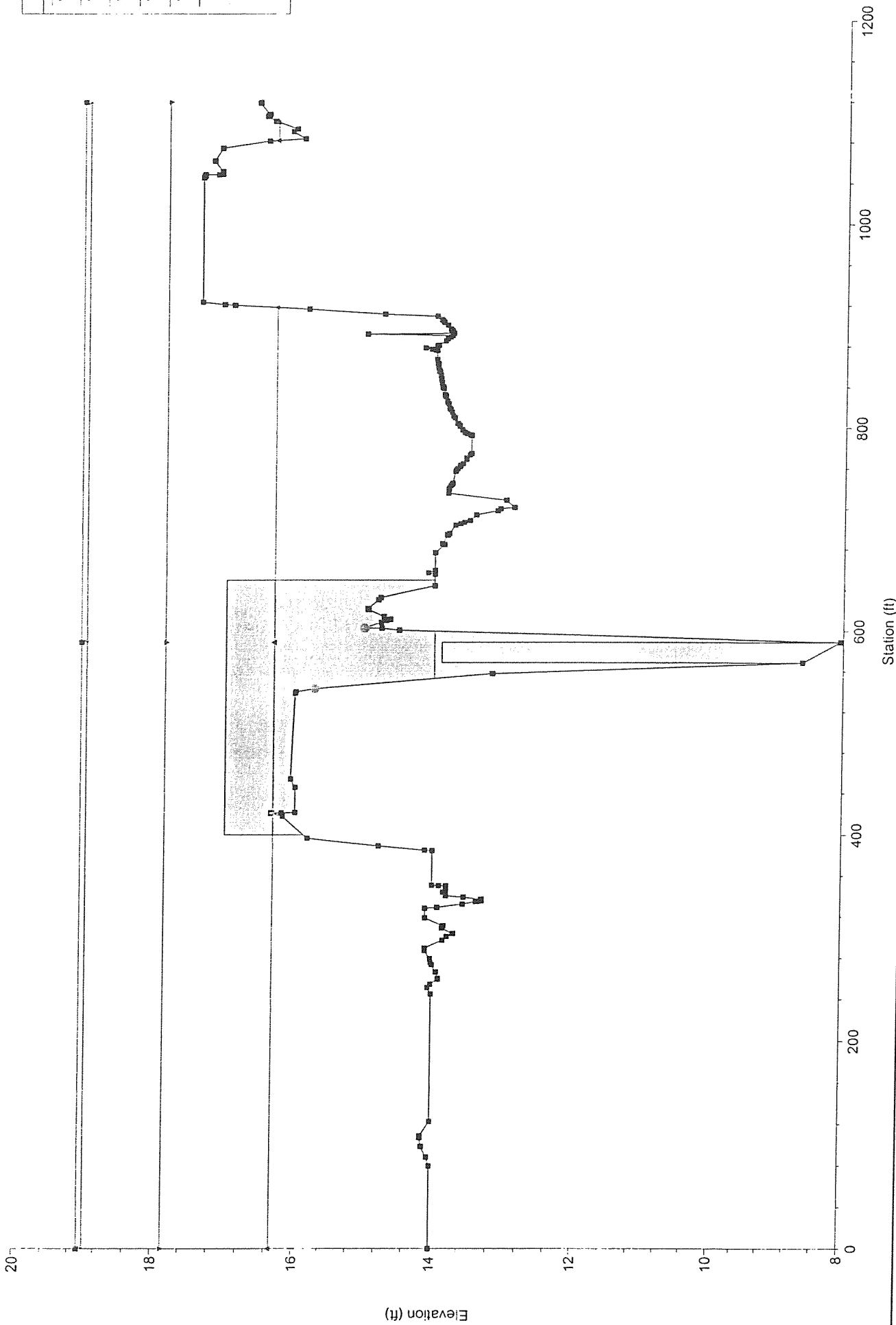

Legend	
—■—	WS 3000
—■—	WS 2500
—■—	WS 2000
—■—	WS 1500
—■—	WS 1000
—	Ground
—	Levee
—●—	Bank Sta

Sycamore Creek Plan: EXISTING-WITH BRIDGES 3/10/2003  
 RS = 1723.388 101 BRIDGE - DOWNSTREAM SIDE - RS 1723

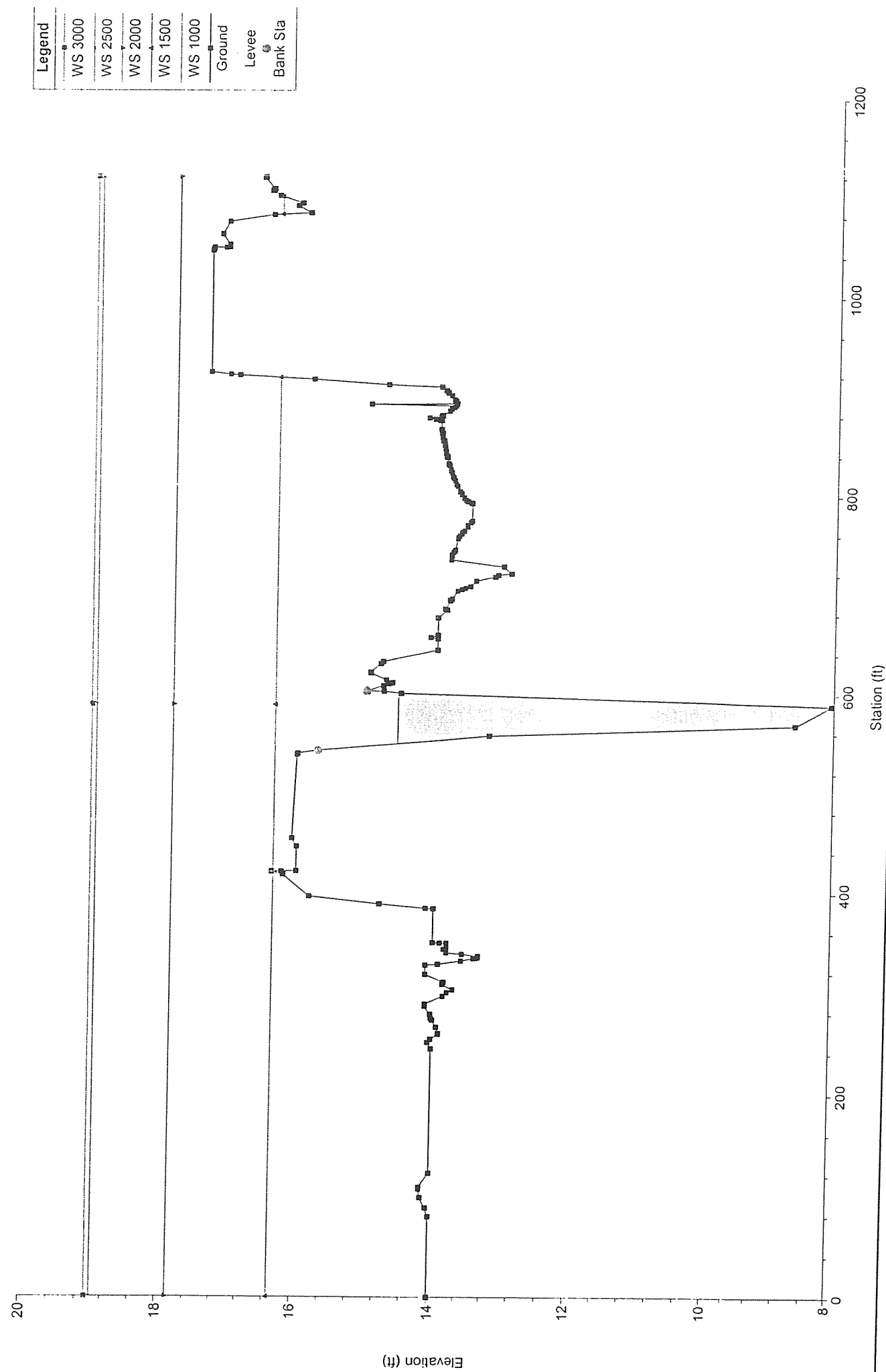

Legend	
—■—	WS 3000
—■—	WS 2500
—■—	WS 2000
—■—	WS 1500
—■—	WS 1000
—■—	Ground
—■—	Levee
○	Bank Sta

Sycamore Creek Plan: EXISTING-WITH BRIDGES 3/10/2003  
 RS = 1674.270 RR BRIDGE - UPSTREAM SIDE - RS 1674

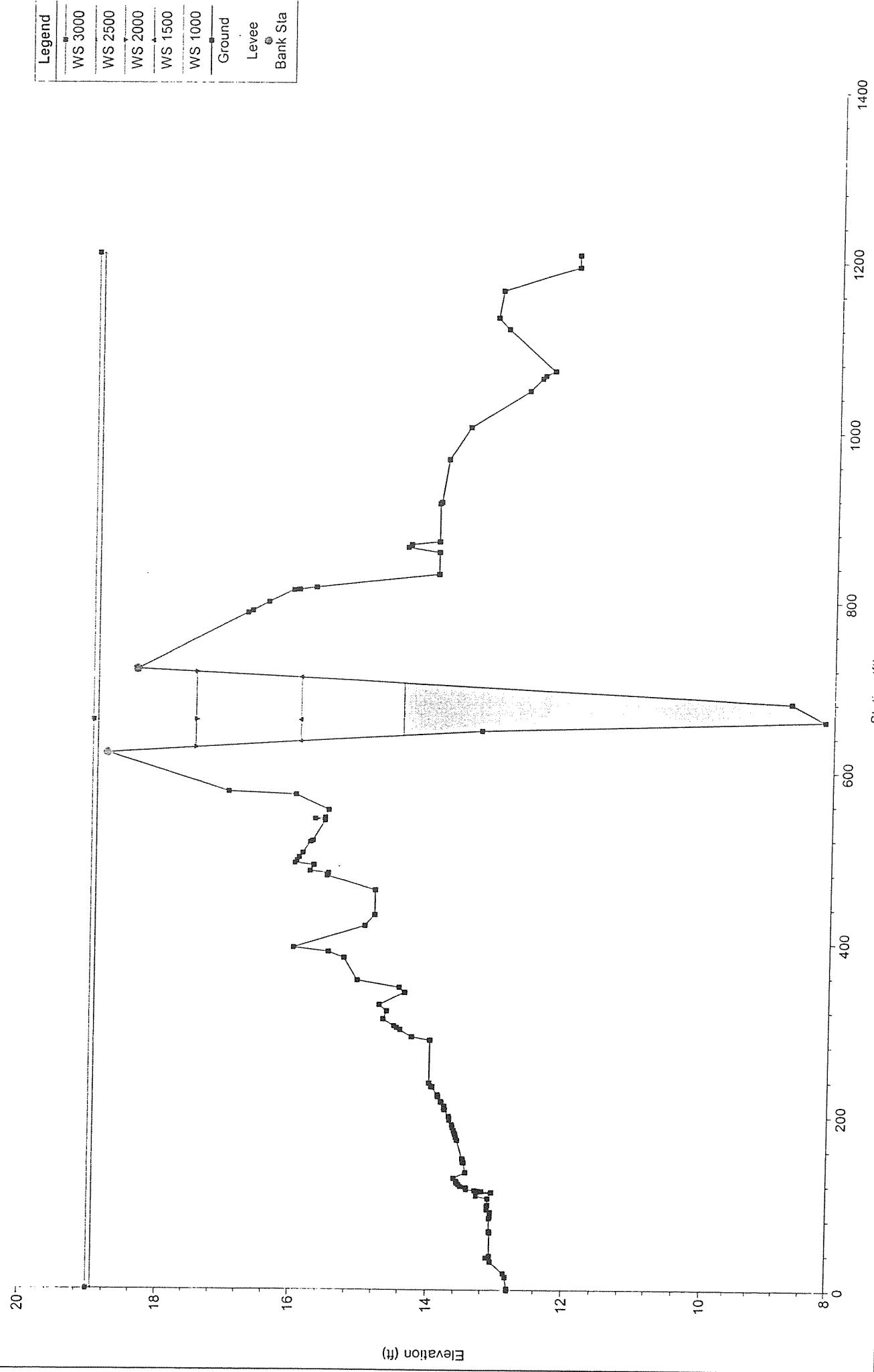

Legend	
WS 3000	—■—
WS 2500	—■—
WS 2000	—■—
WS 1500	—■—
WS 1000	—■—
Ground	—■—
Levee	—■—
Bank Sta	—■—

Sycamore Creek Plan: EXISTING-WITH BRIDGES 3/10/2003  
 RS = 1655 BR RR BRIDGE (B)

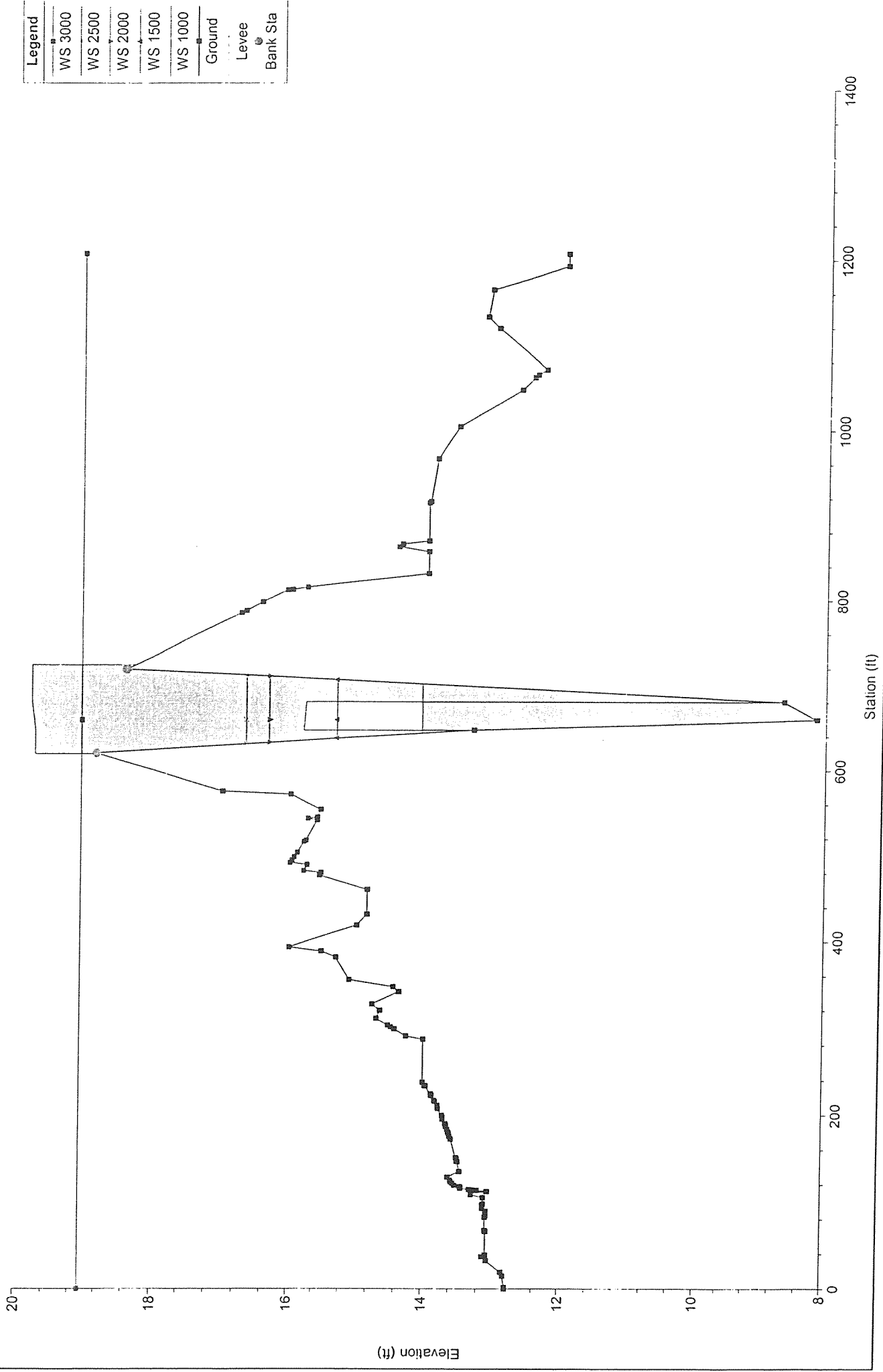

Legend	
WS 3000	—
WS 2500	—
WS 2000	—
WS 1500	—
WS 1000	—
Ground	■
Levee	—
Bank Sta	●

Sycamore Creek Plan: EXISTING-WITH BRIDGES 3/10/2003  
 RS = 1655 BR RR BRIDGE (B)

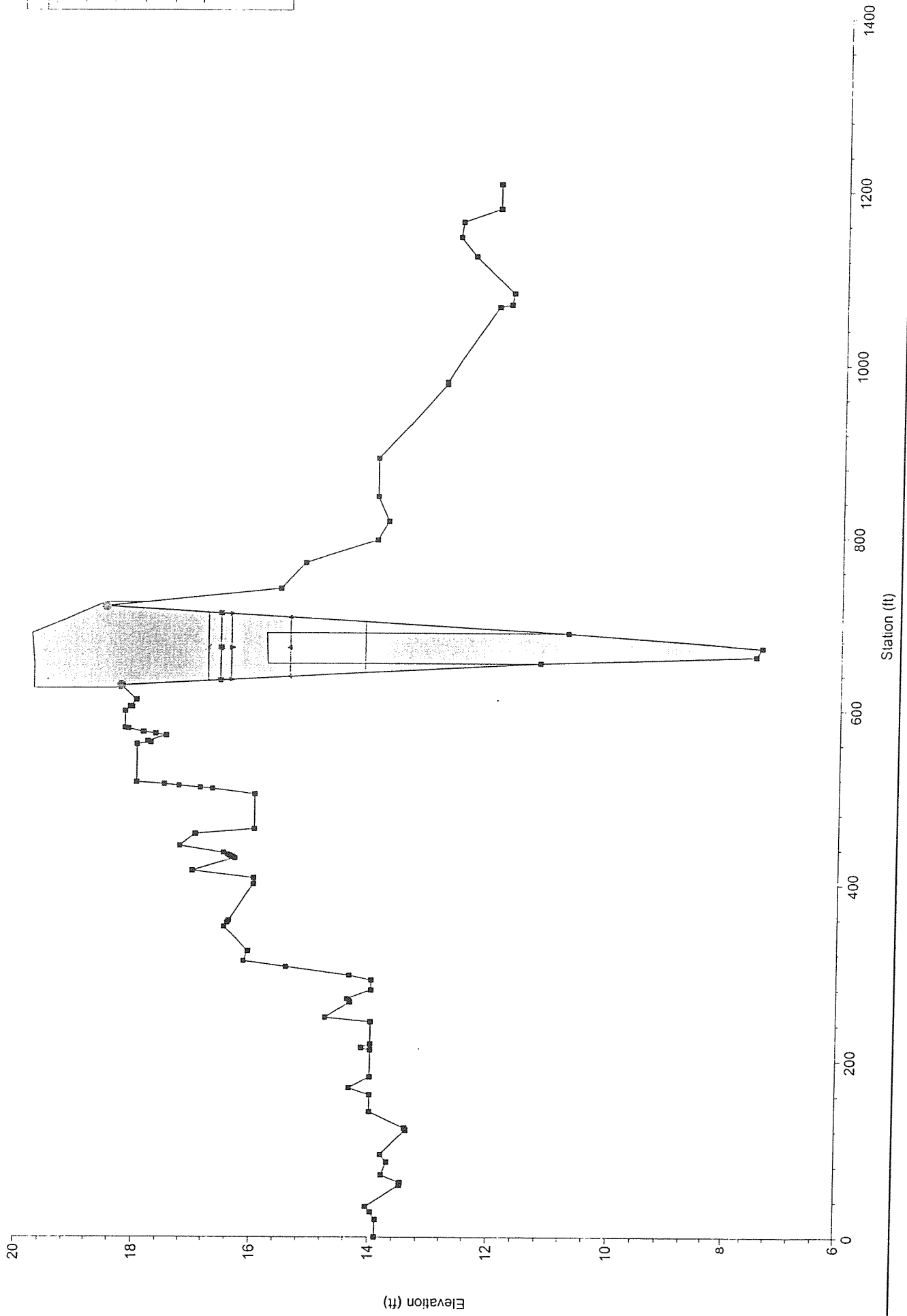

Legend	
WS 2500	—
WS 3000	—
WS 2000	—
WS 1500	—
WS 1000	—
Ground	- - -
Levee	—
Bank Sta	●

Sycamore Creek Plan: EXISTING-WITH BRIDGES 3/10/2003  
 RS = 1652.758 RR BRIDGE - DOWNSTREAM SIDE - RS 1652

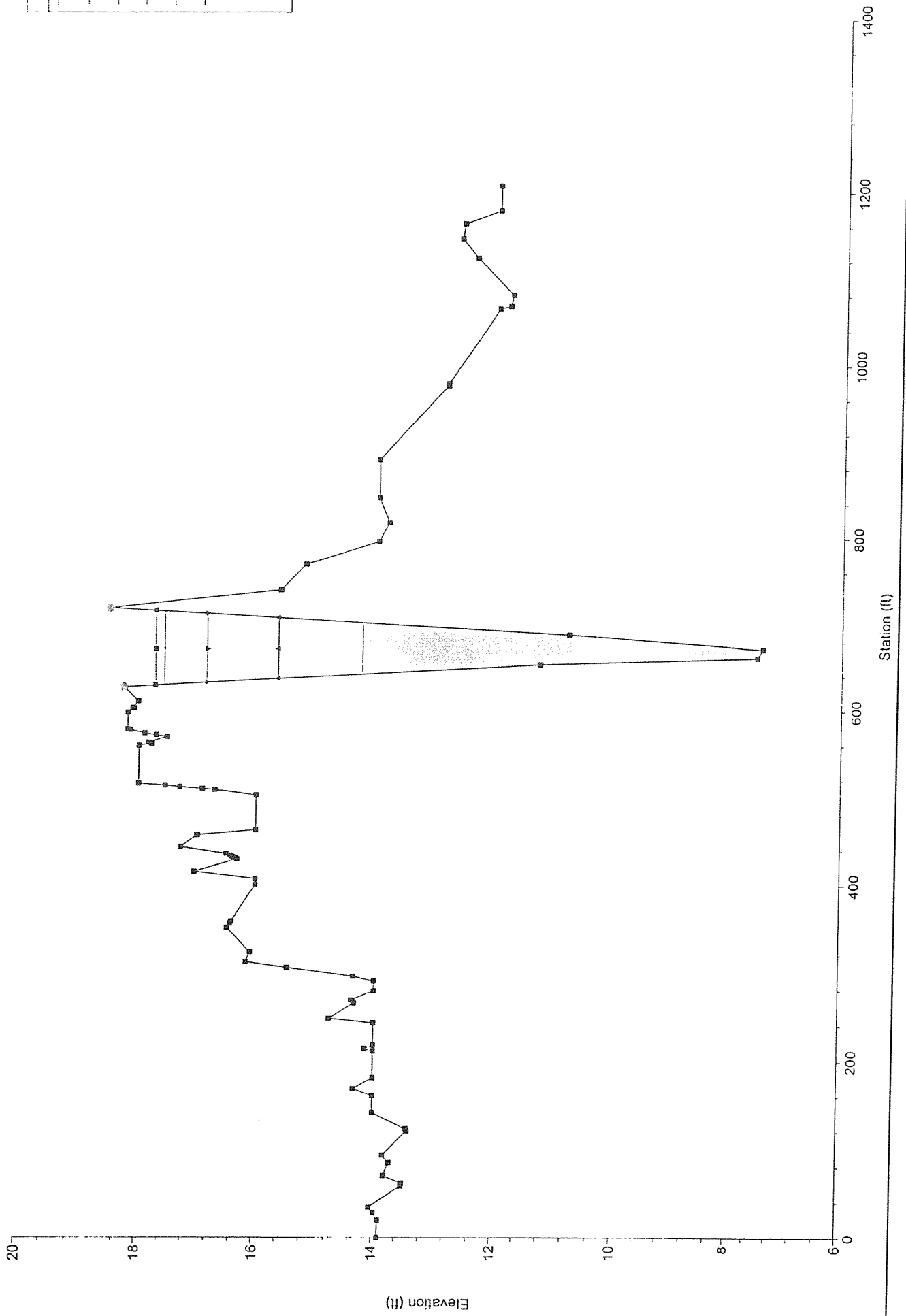

Legend	
—■—	WS 3000
—■—	WS 2500
—■—	WS 2000
—■—	WS 1500
—■—	WS 1000
—	Ground
- - -	Levee
●	Bank Sta

Sycamore Creek Plan: EXISTING-WITH BRIDGES 3/10/2003  
 RS = 1510.343 BETWEEN ZOO AND RAILROAD - RS 1510

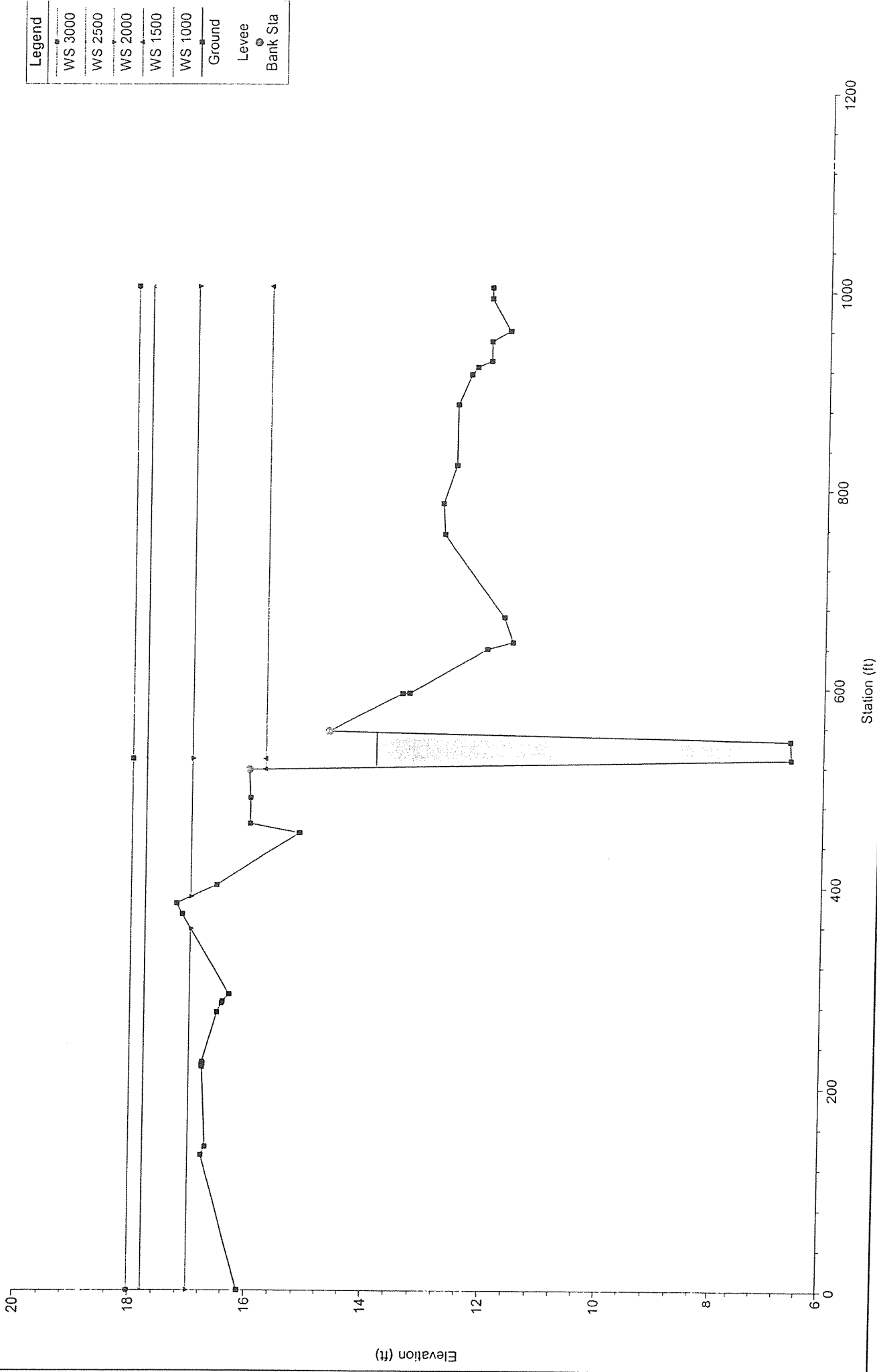

Legend	
—	WS 3000
—	WS 2500
—	WS 2000
—	WS 1500
—	WS 1000
—	Ground
—	Levee
●	Bank Sta



Sycamore Creek Plan: EXISTING-WITH BRIDGES 3/10/2003  
 RS = 1328.387 ZOO BRIDGE - UPSTREAM SIDE - RS 1328

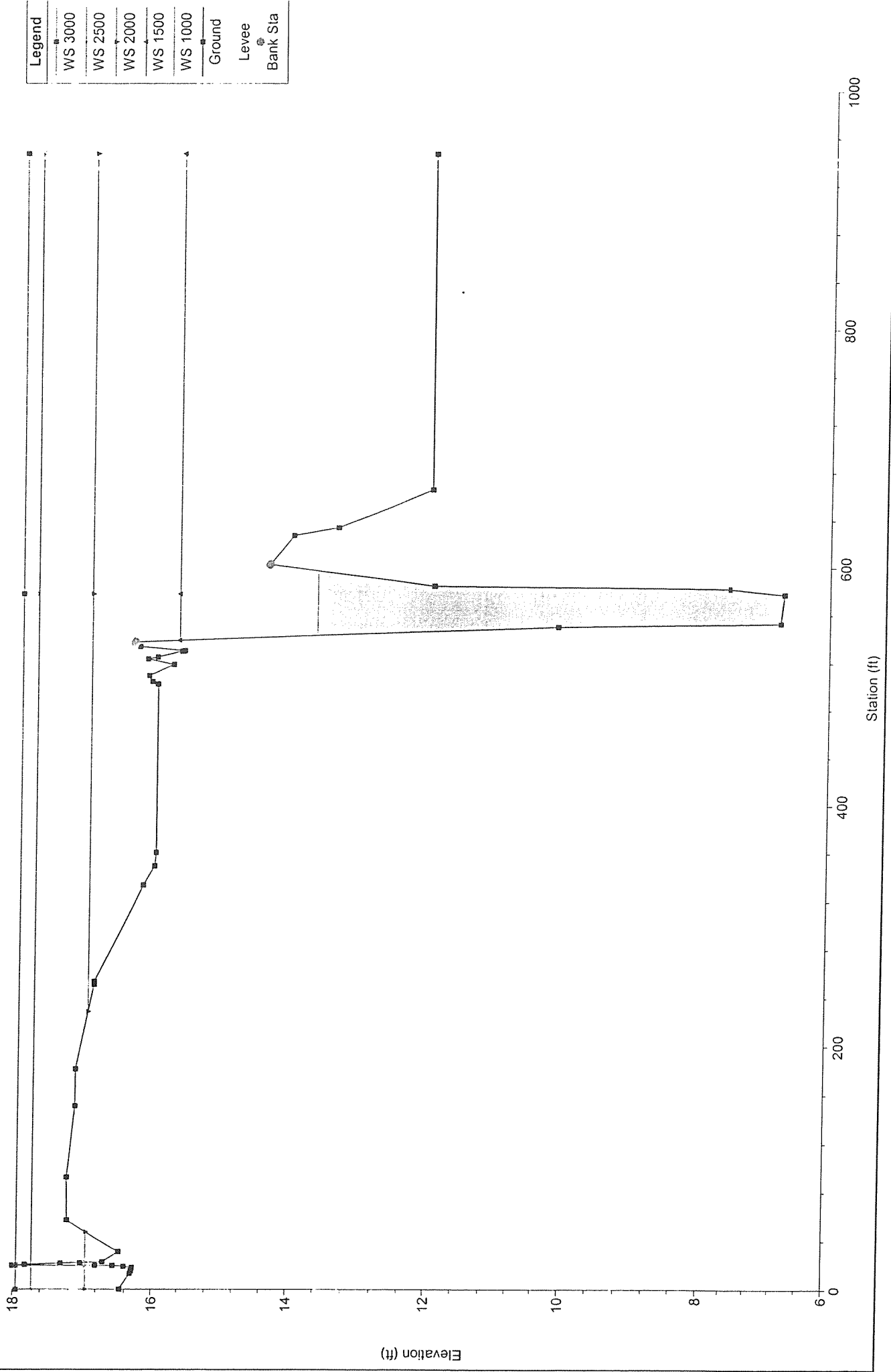

Legend	
WS 3000	—■—
WS 2500	—■—
WS 2000	—■—
WS 1500	—■—
WS 1000	—■—
Ground	—■—
Levee	—■—
Bank Sta	●

Sycamore Creek Plan: EXISTING-WITH BRIDGES 3/10/2003  
 RS = 1282 BR ZOO BRIDGE (C)

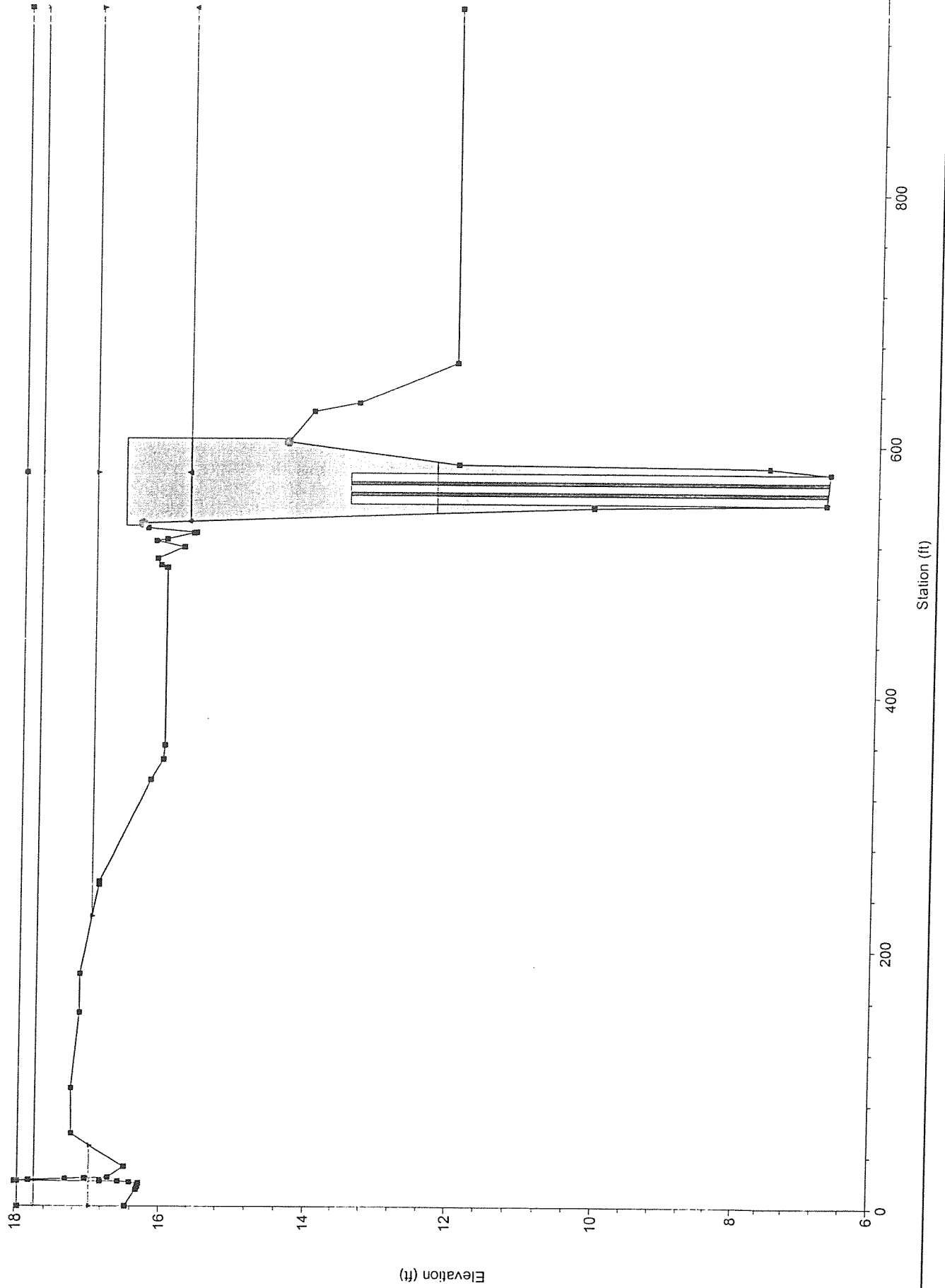

Legend	
WS 3000	—
WS 2500	—
WS 2000	—
WS 1500	—
WS 1000	—
Ground	—
Levee	—
Bank Sta	—
Pier Debris	—

Sycamore Creek Plan: EXISTING-WITH BRIDGES 3/10/2003  
 RS = 1282 BR ZOO BRIDGE (C)

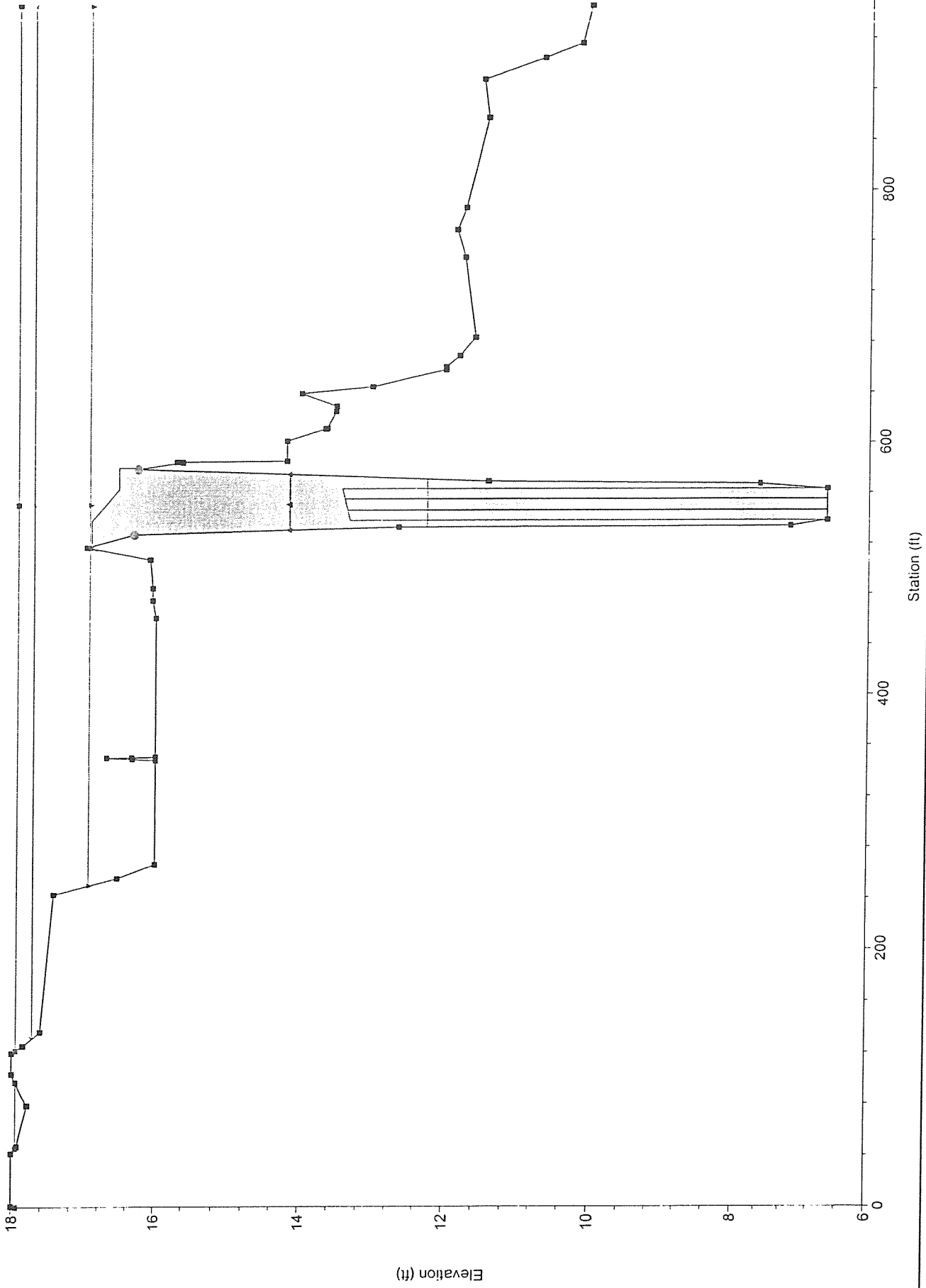

Legend	
—■—	WS 3000
—■—	WS 2500
—■—	WS 2000
—■—	WS 1500
—■—	WS 1000
—■—	Ground
▨	Levee
●	Bank Sta

Sycamore Creek Plan: EXISTING-WITH BRIDGES 3/10/2003  
 RS = 1270.314 ZOO BRIDGE - DOWNSTREAM SIDE - RS 1270

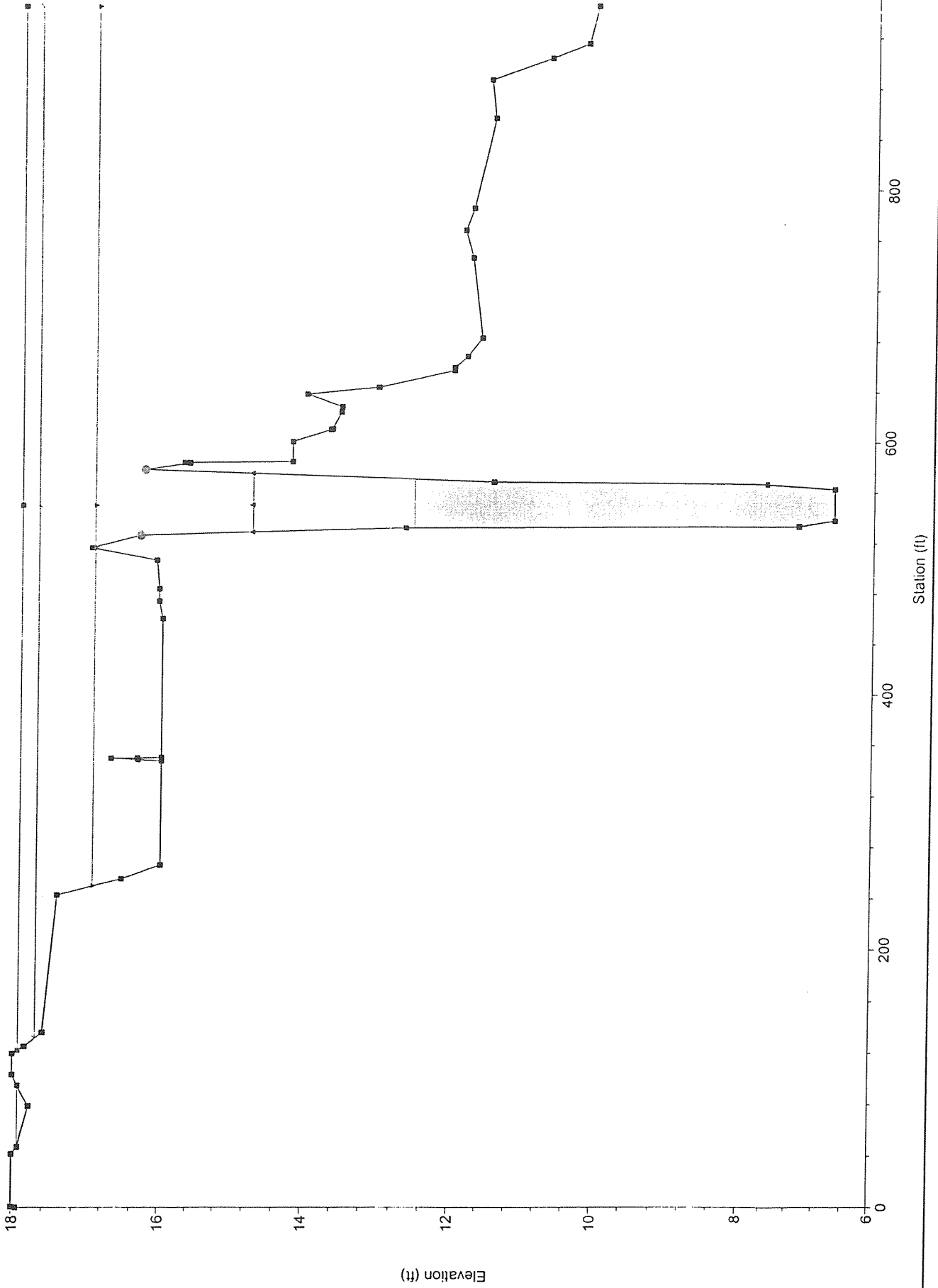

Legend	
WS 3000	—■—
WS 2500	—■—
WS 2000	—■—
WS 1500	—■—
WS 1000	—■—
Ground	—■—
Levee	—■—
Bank Sta	—■—

Sycamore Creek Plan: EXISTING-WITH BRIDGES 3/10/2003  
RS = 1214.093 BETWEEN POR LA MAR #2 AND ZOO - RS 1214

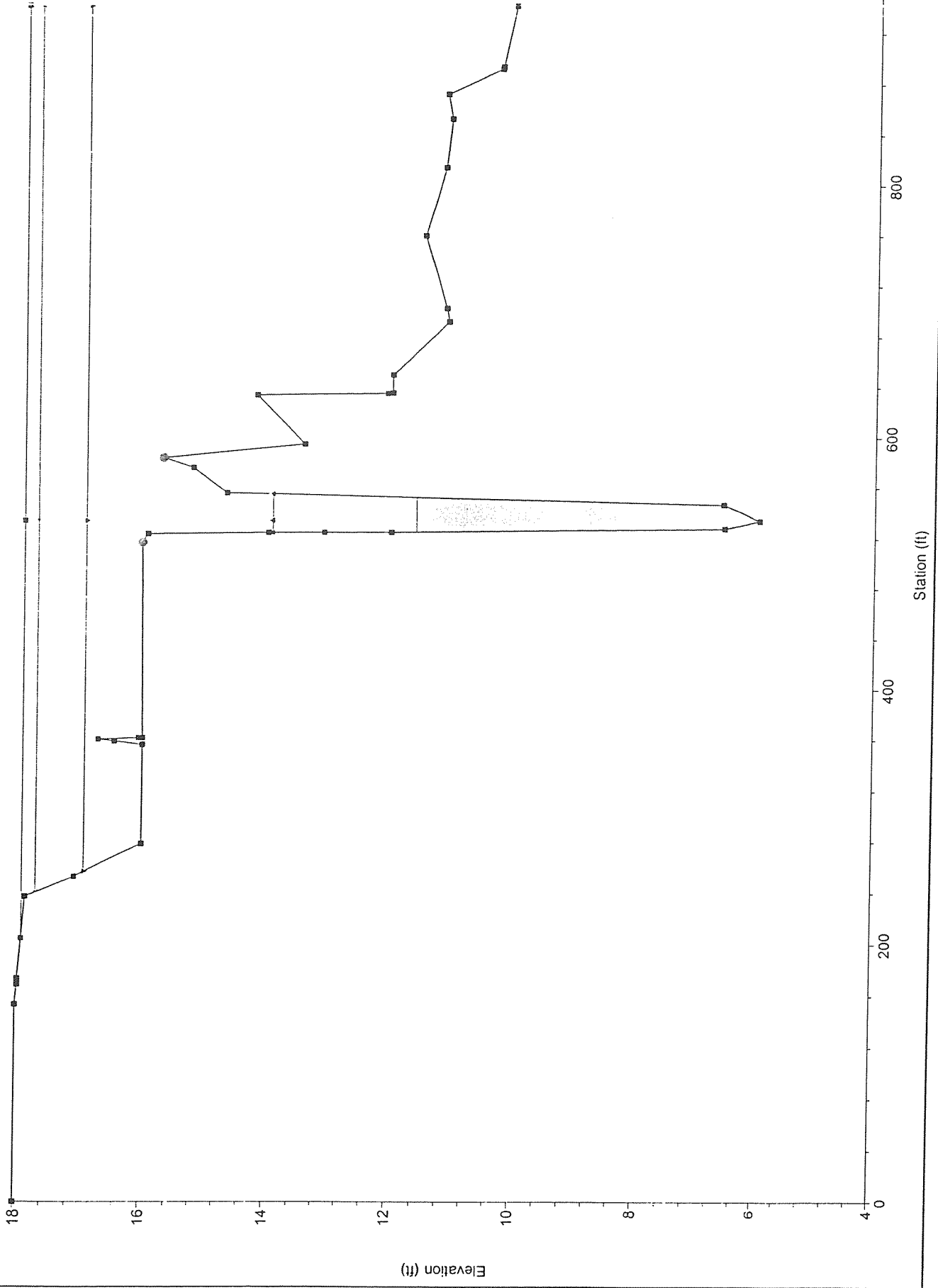

Legend	
—■—	WS 3000
—●—	WS 2500
—▲—	WS 2000
—▼—	WS 1500
—◆—	WS 1000
—	Ground
—○—	Levee
— —	Bank Sta

Sycamore Creek Plan: EXISTING-WITH BRIDGES 3/10/2003  
 RS = 1161.097 POR LA MAR CIRCLE #2 - UPSTREAM SIDE - RS 1161

Legend	
—■—	WS 3000
—●—	WS 2500
—▲—	WS 2000
—◆—	WS 1500
—□—	WS 1000
—	Ground
—○—	Levee
—●—	Bank Sta

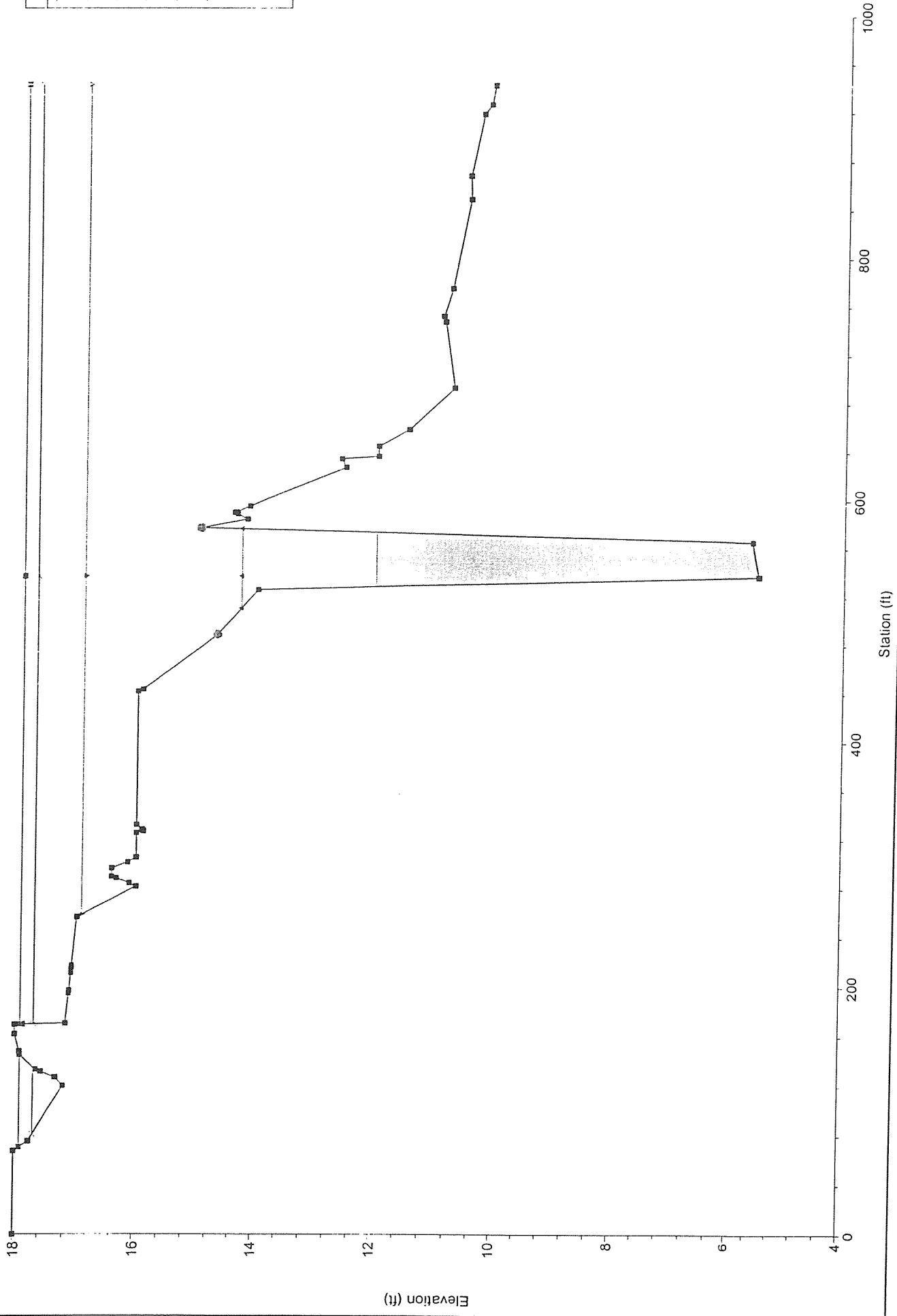

Sycamore Creek Plan: EXISTING-WITH BRIDGES 3/10/2003  
 RS = 1123 BR FOR LA MAR BRIDGE #2 (D)

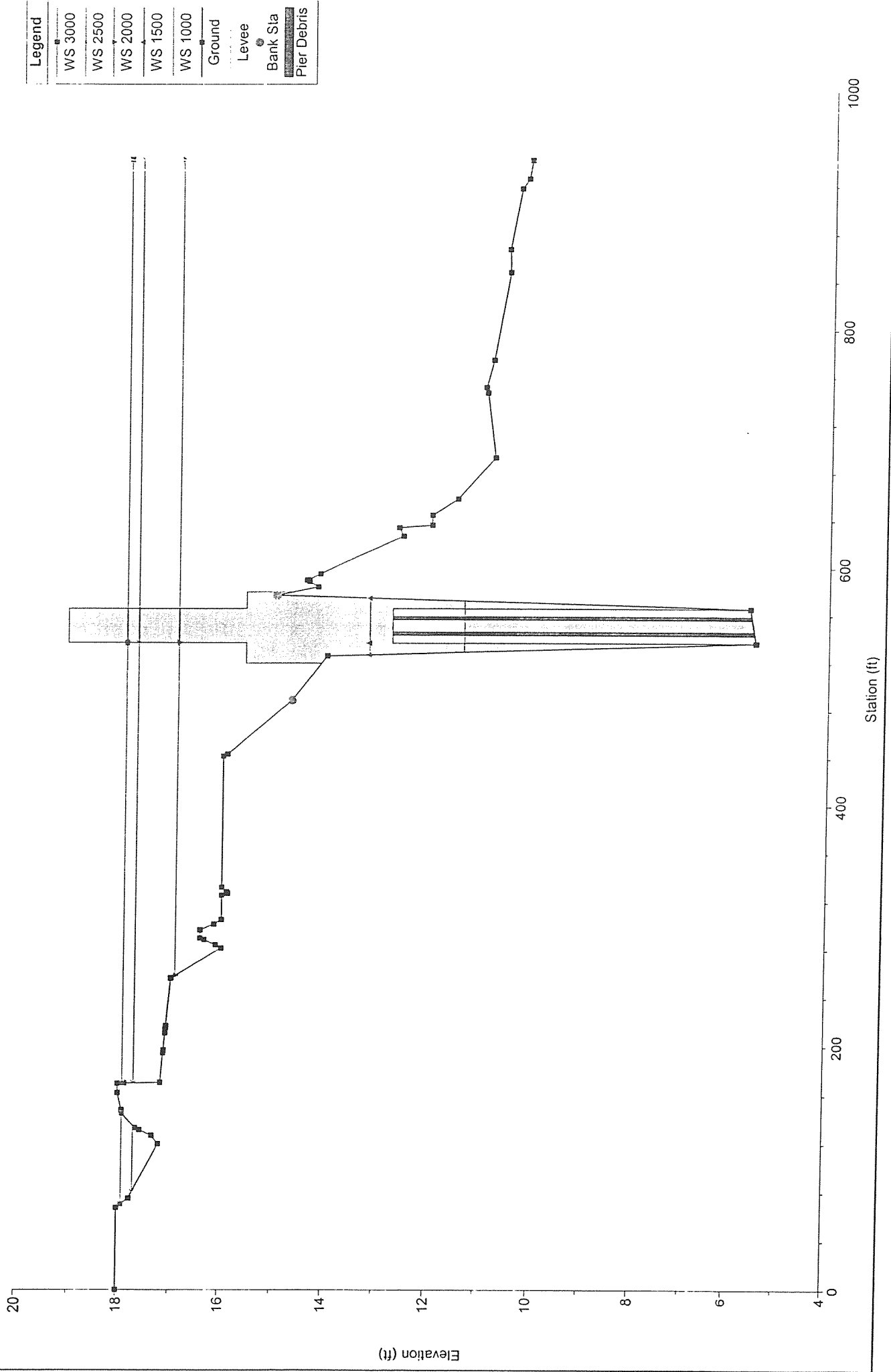

Sycamore Creek Plan: EXISTING-WITH BRIDGES 3/10/2003  
 RS = 1123 BR POR LA MAR BRIDGE #2 (D)

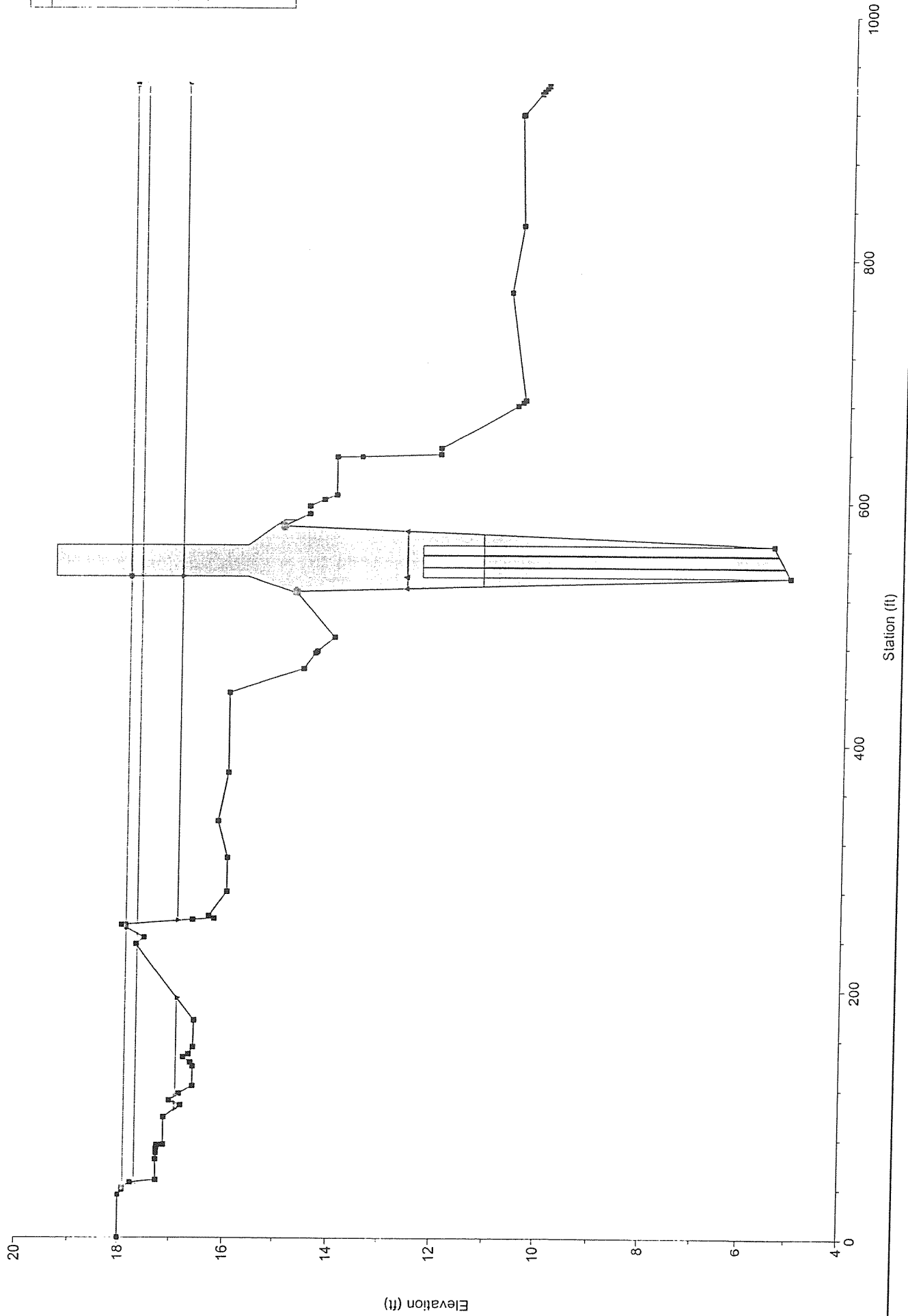



Sycamore Creek Plan: EXISTING-WITH BRIDGES 3/10/2003  
 RS = 1110.025 POR LA MAR CIRCLE #2 - DOWNSTREAM SIDE - RS 1110

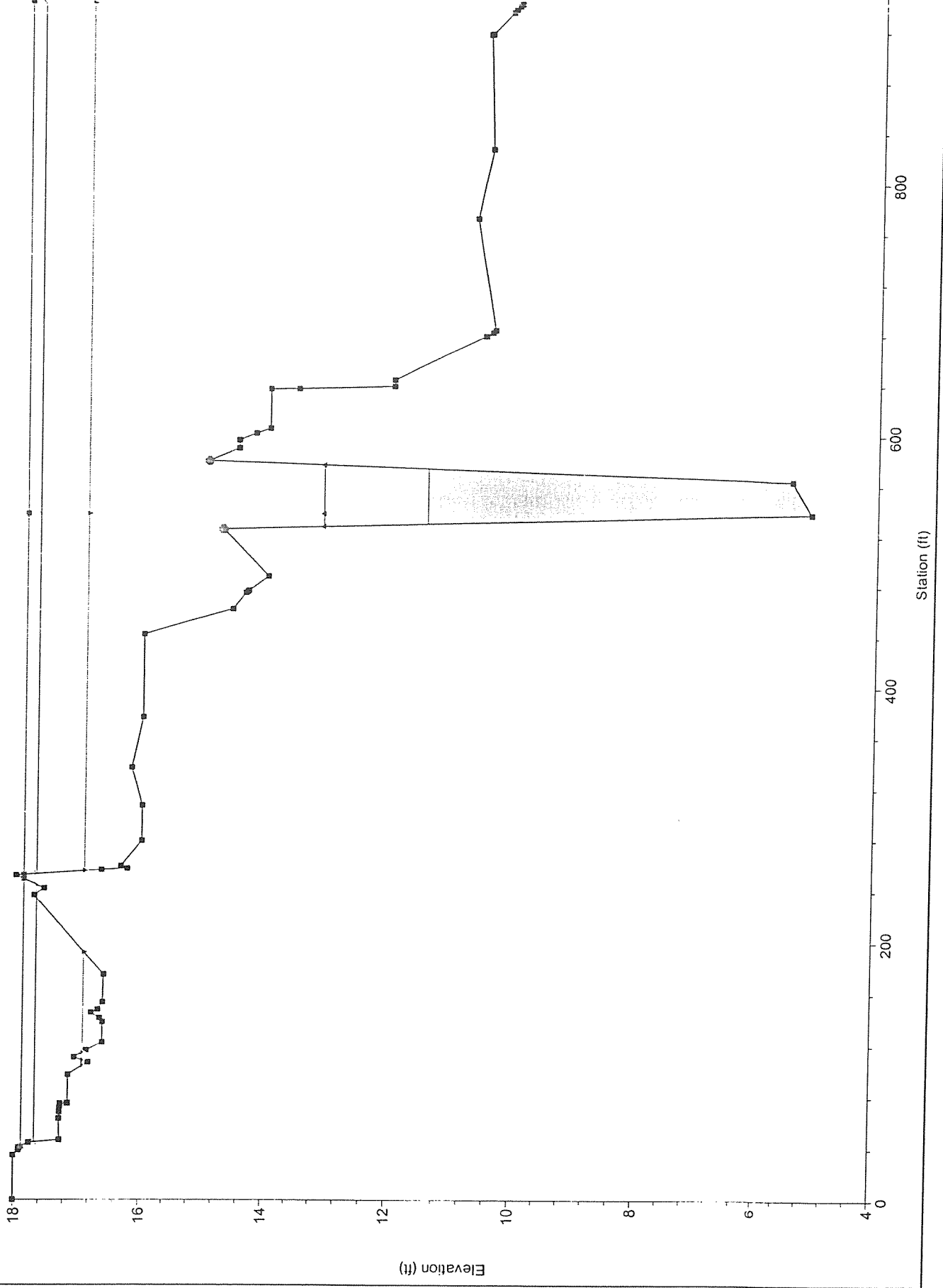

Legend	
WS 3000	□
WS 2500	□
WS 2000	□
WS 1500	□
WS 1000	□
Ground	—
Levee	- - -
Bank Sta	●

Sycamore Creek Plan: EXISTING-WITH BRIDGES 3/10/2003  
 RS = 932.393 BETWEEN POR LA MAR #1 AND #2 - RS 932

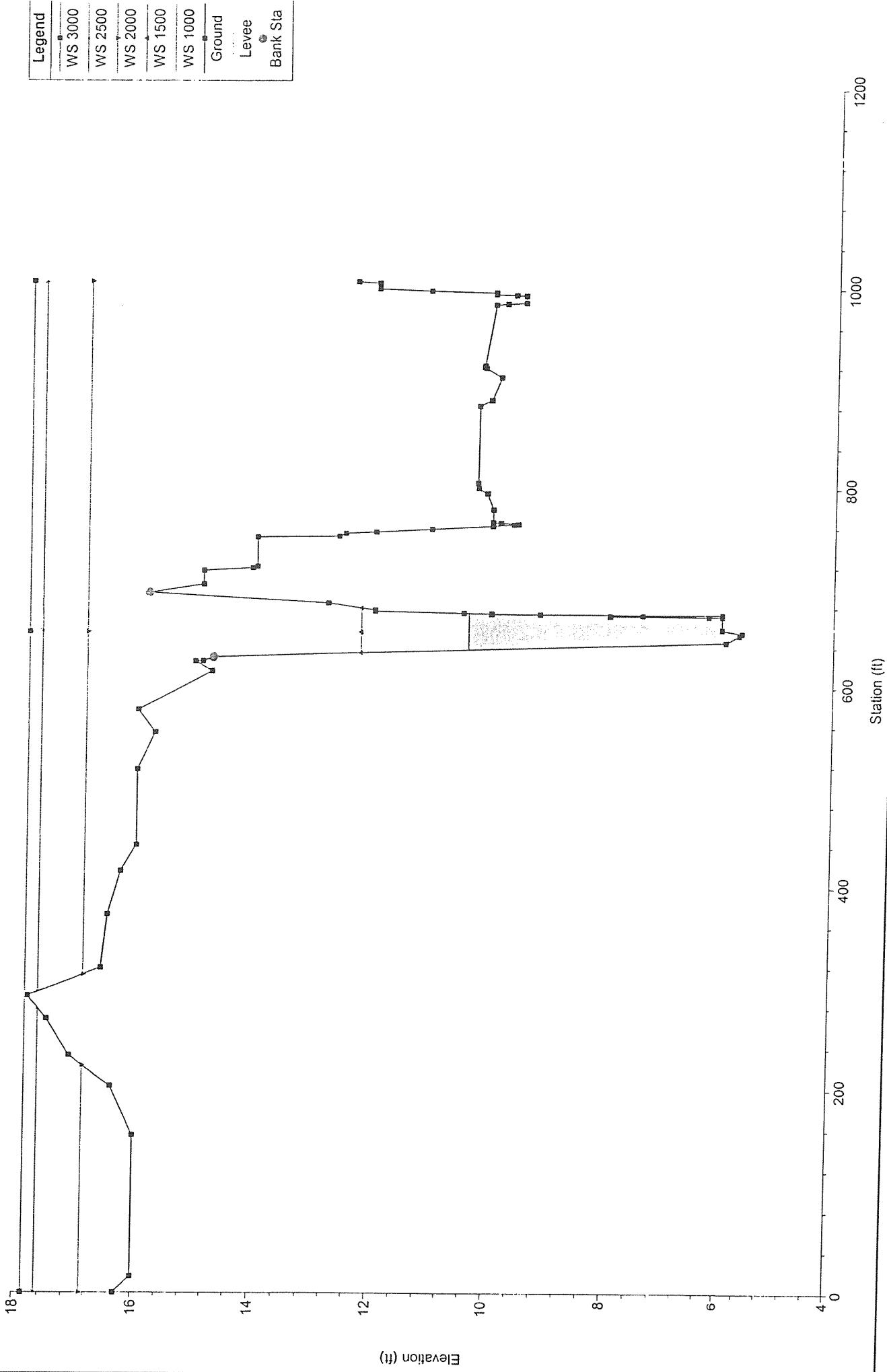

Legend	
WS 3000	—■—
WS 2500	—■—
WS 2000	—■—
WS 1500	—■—
WS 1000	—■—
Ground	.....
Levee	- - - -
Bank Sta	●

Sycamore Creek Plan: EXISTING-WITH BRIDGES 3/10/2003  
 RS = 755.267 POR LA MAR CIRCLE #1 - UPSTREAM SIDE - RS 755

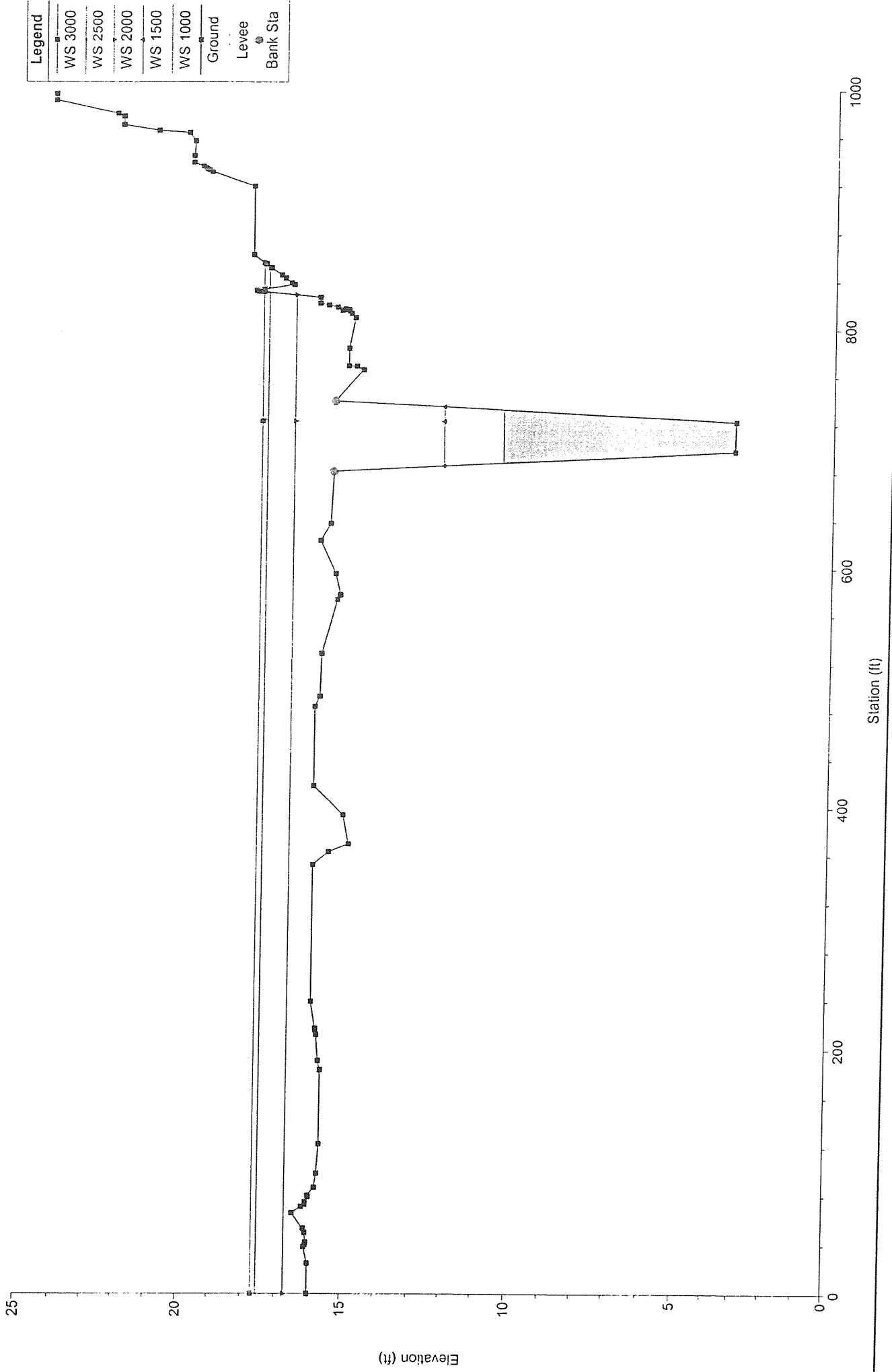

Legend	
—■—	WS 3000
—■—	WS 2500
—■—	WS 2000
—■—	WS 1500
—■—	WS 1000
.....	Ground
—	Levee
●	Bank Sta

Sycamore Creek Plan: EXISTING-WITH BRIDGES 3/10/2003  
RS = 718 BR POR LA MAR BRIDGE #1 (E)

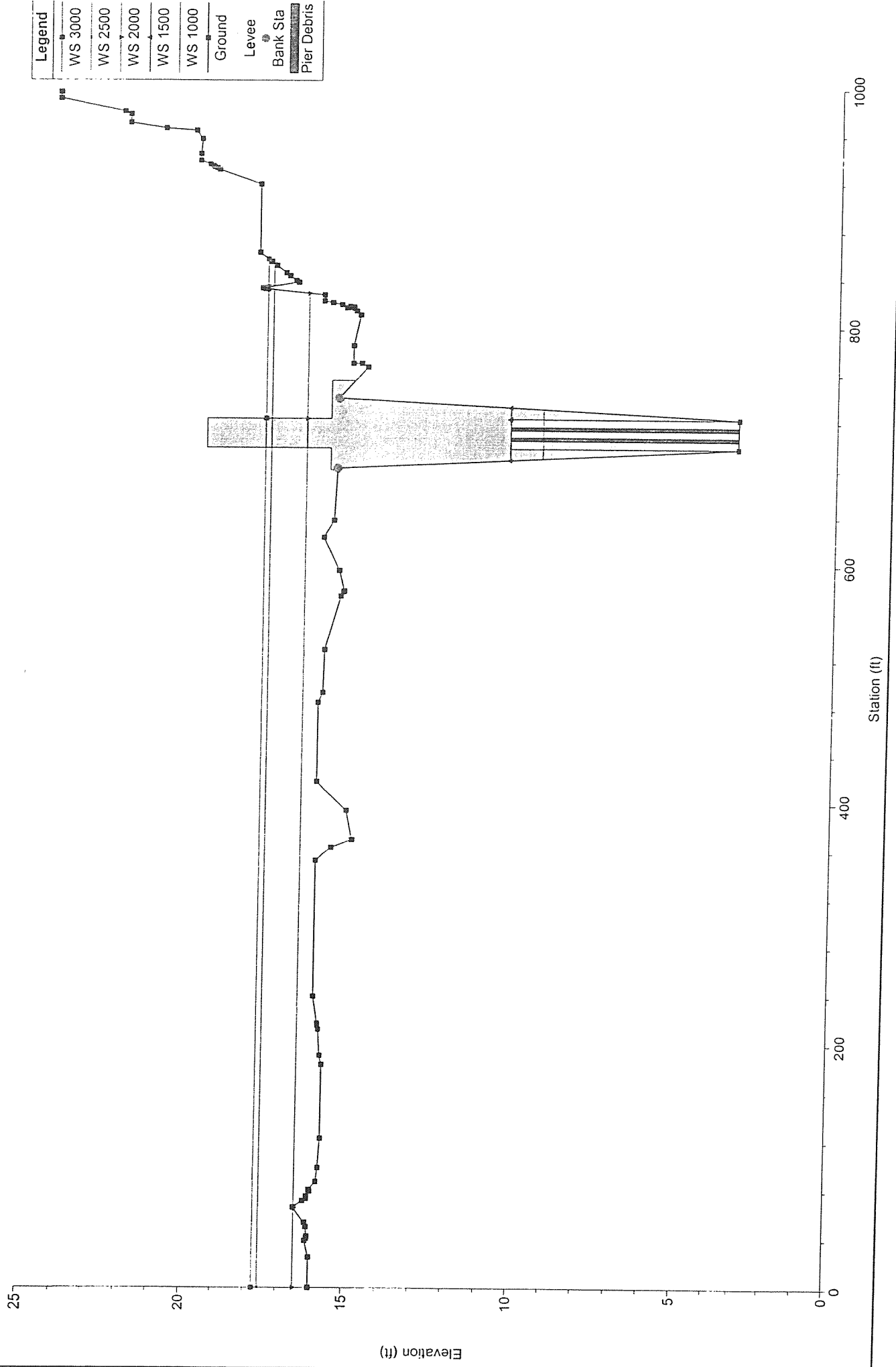

Sycamore Creek Plan: EXISTING-WITH BRIDGES 3/10/2003  
 RS = 718 BR FOR LA MAR BRIDGE #1 (E)

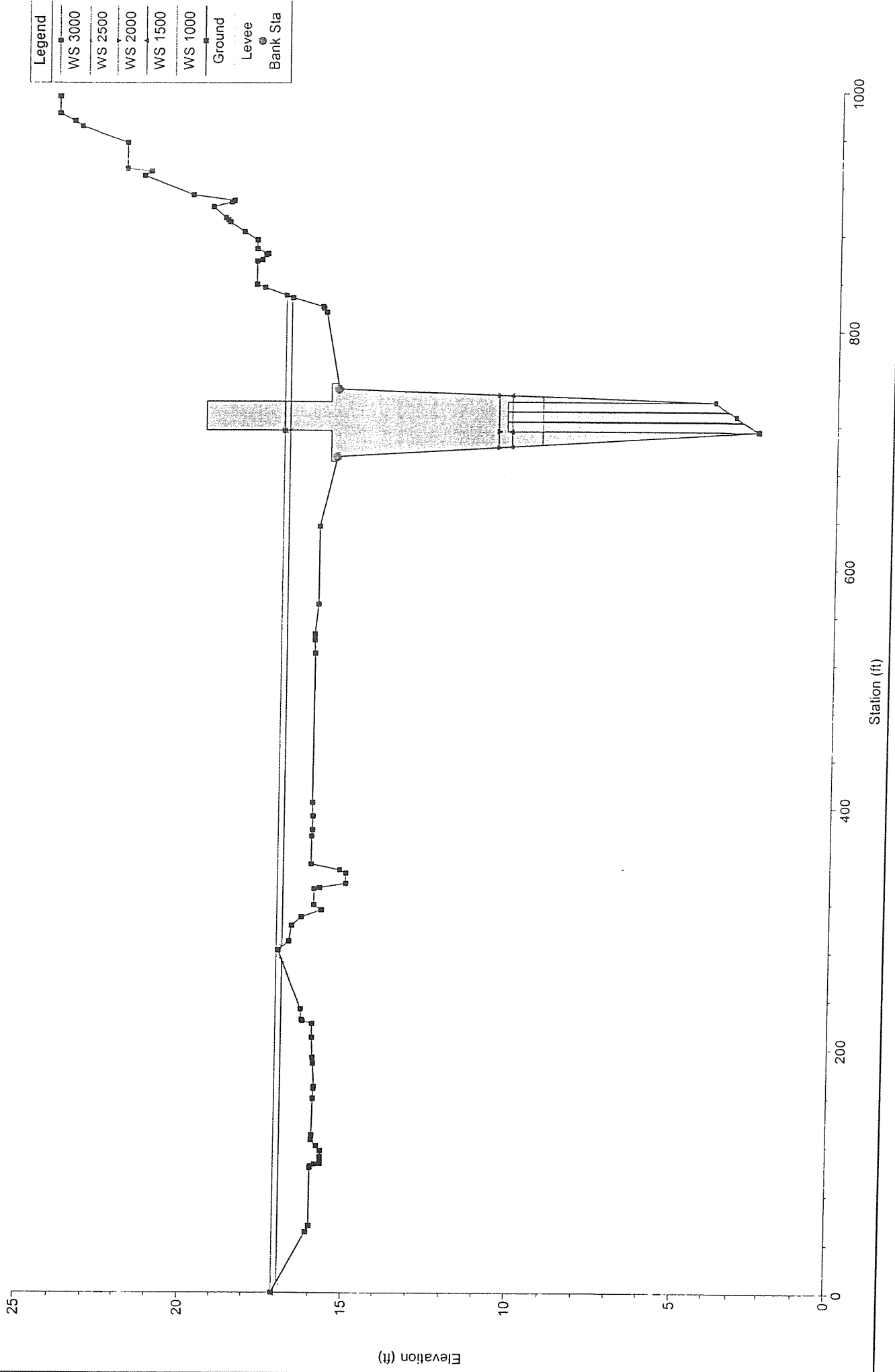

Sycamore Creek Plan: EXISTING-WITH BRIDGES 3/10/2003  
 RS = 710.610 POR LA MAR CIRCLE #1 - DOWNSTREAM SIDE - RS 710

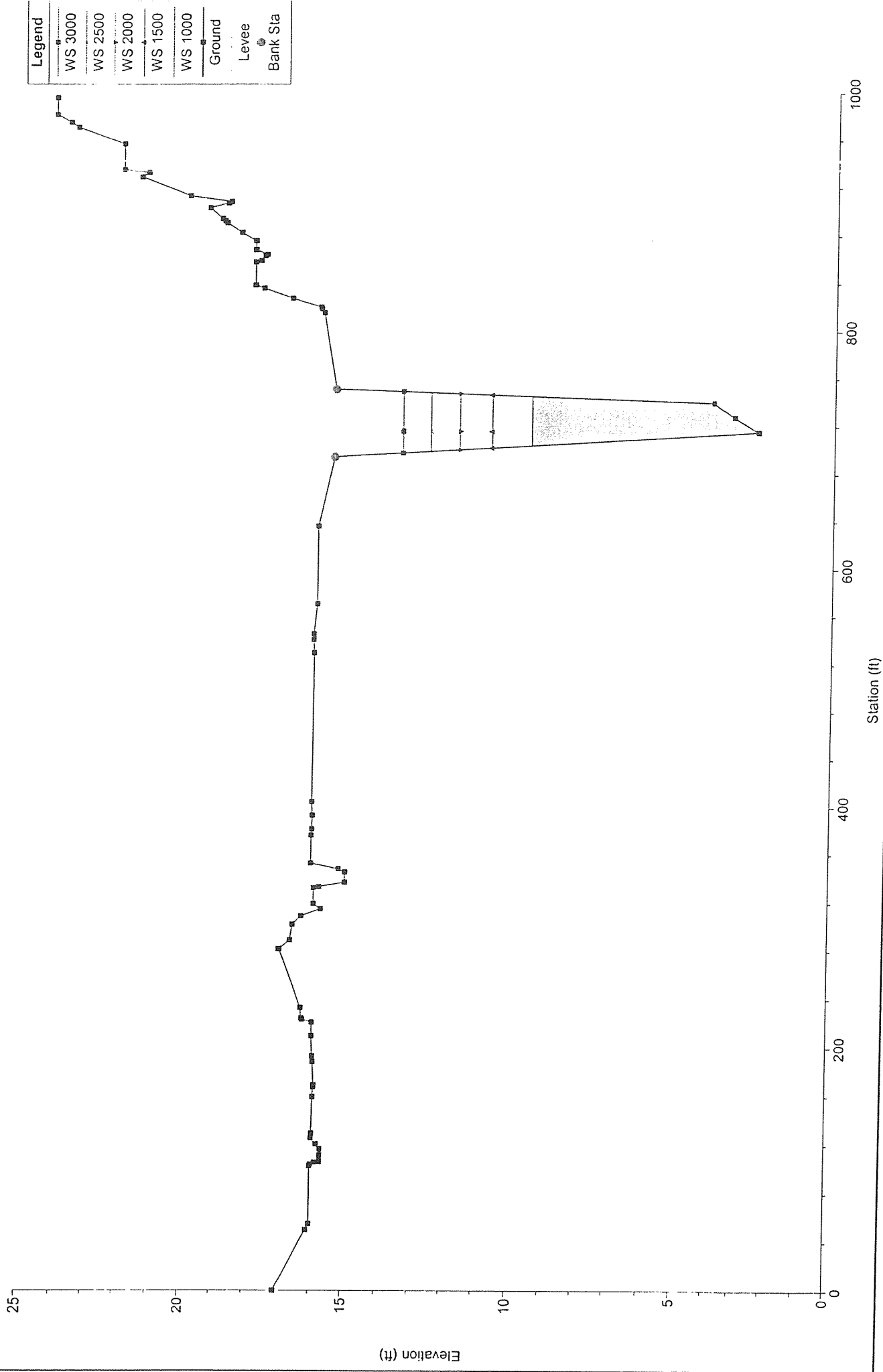

Legend	
WS 3000	□
WS 2500	○
WS 2000	△
WS 1500	▽
WS 1000	◇
Ground	—
Levee	—
Bank Sta	—

Sycamore Creek Plan: EXISTING-WITH BRIDGES 3/10/2003  
 RS = 604.965 BETWEEN CABRILLO AND POR LA MAR #1 - RS 604

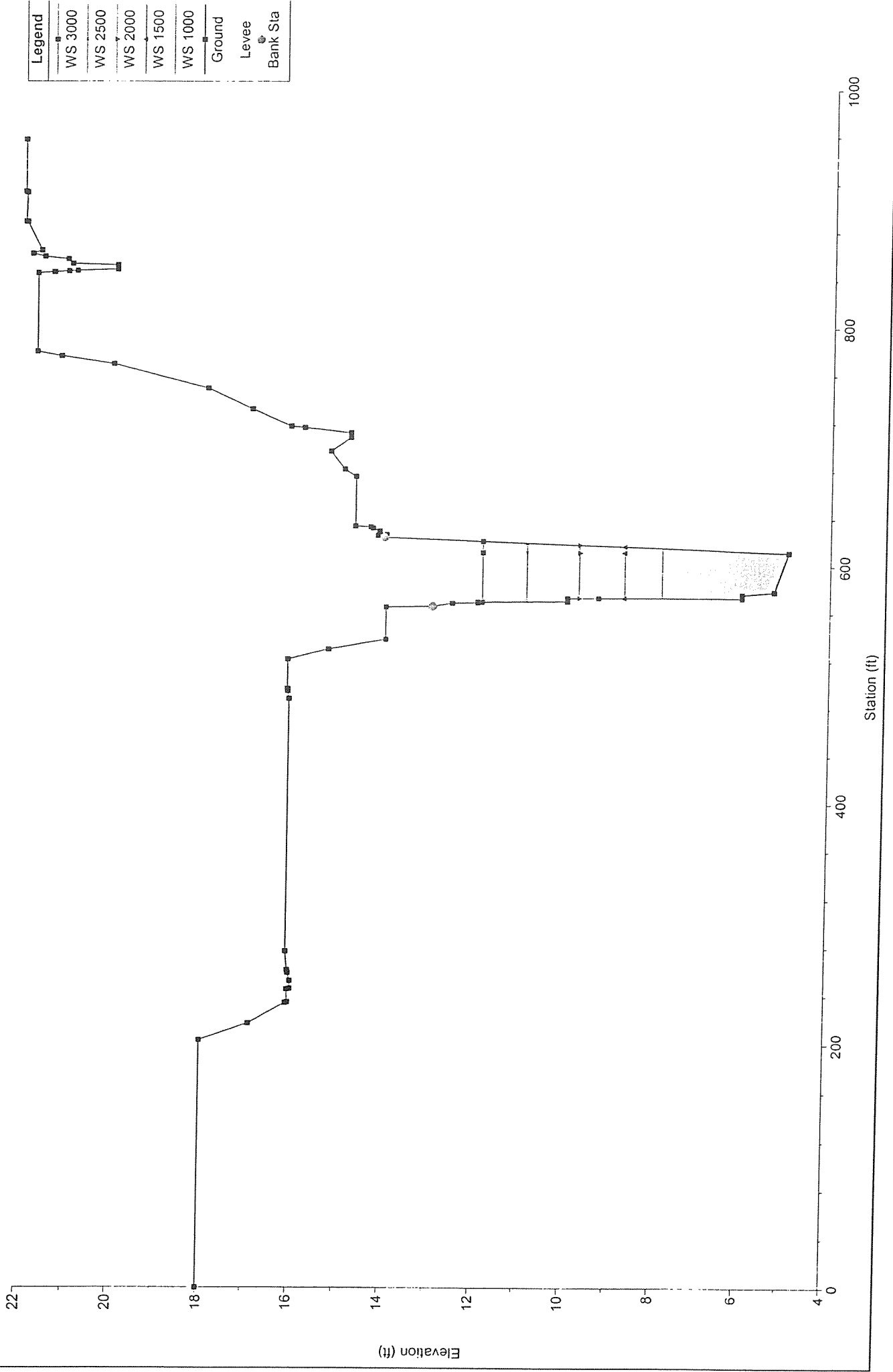

Legend	
—■—	WS 3000
- - -■- - -	WS 2500
- · - · - · -	WS 2000
- · · - · · -	WS 1500
- · · · - · · · -	WS 1000
—■—	Ground
○	Levee
●	Bank Sta

Sycamore Creek Plan: EXISTING-WITH BRIDGES 3/10/2003  
 RS = 465.300 CABRILLO BRIDGE - UPSTREAM SIDE - RS 465

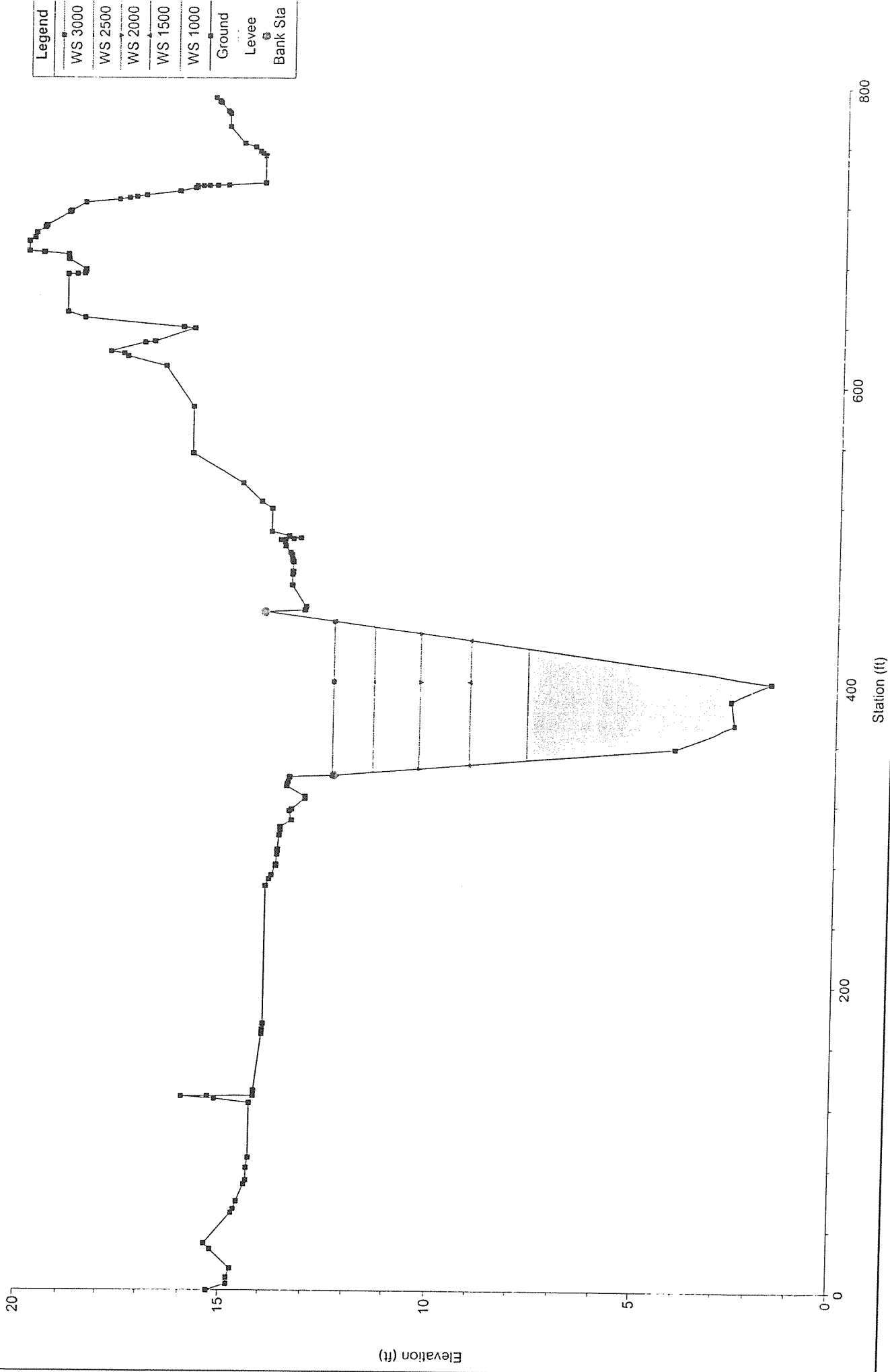

Legend	
□	WS 3000
□	WS 2500
□	WS 2000
□	WS 1500
□	WS 1000
—	Ground
- - -	Levee
⊗	Bank Sta



Sycamore Creek Plan: EXISTING-WITH BRIDGES 3/10/2003  
RS = 384 BR CABRILLO BLVD BRIDGE (F)

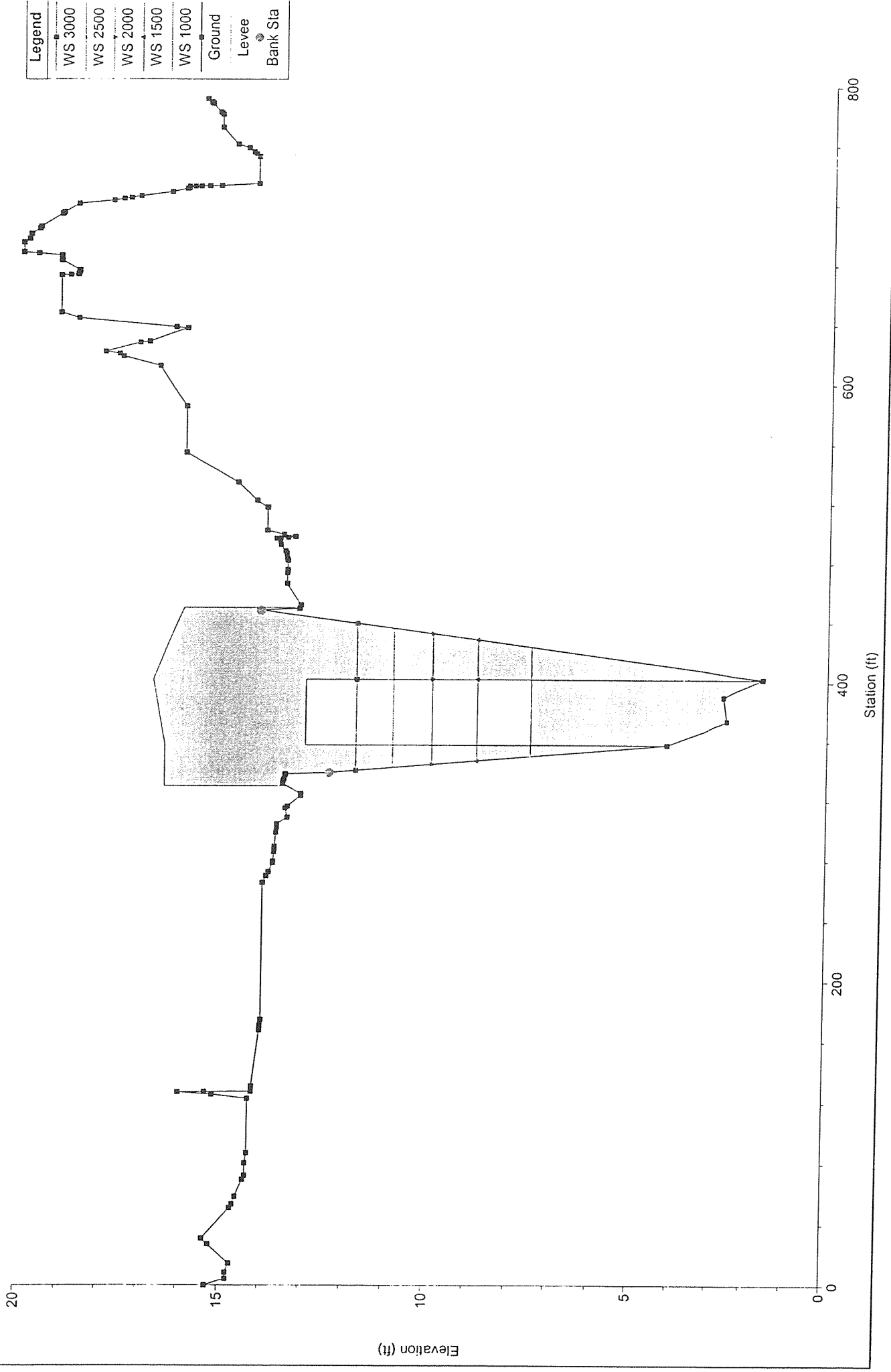

Sycamore Creek Plan: EXISTING-WITH BRIDGES 3/10/2003  
RS = 384 BR CABRILLO BLVD BRIDGE (F)

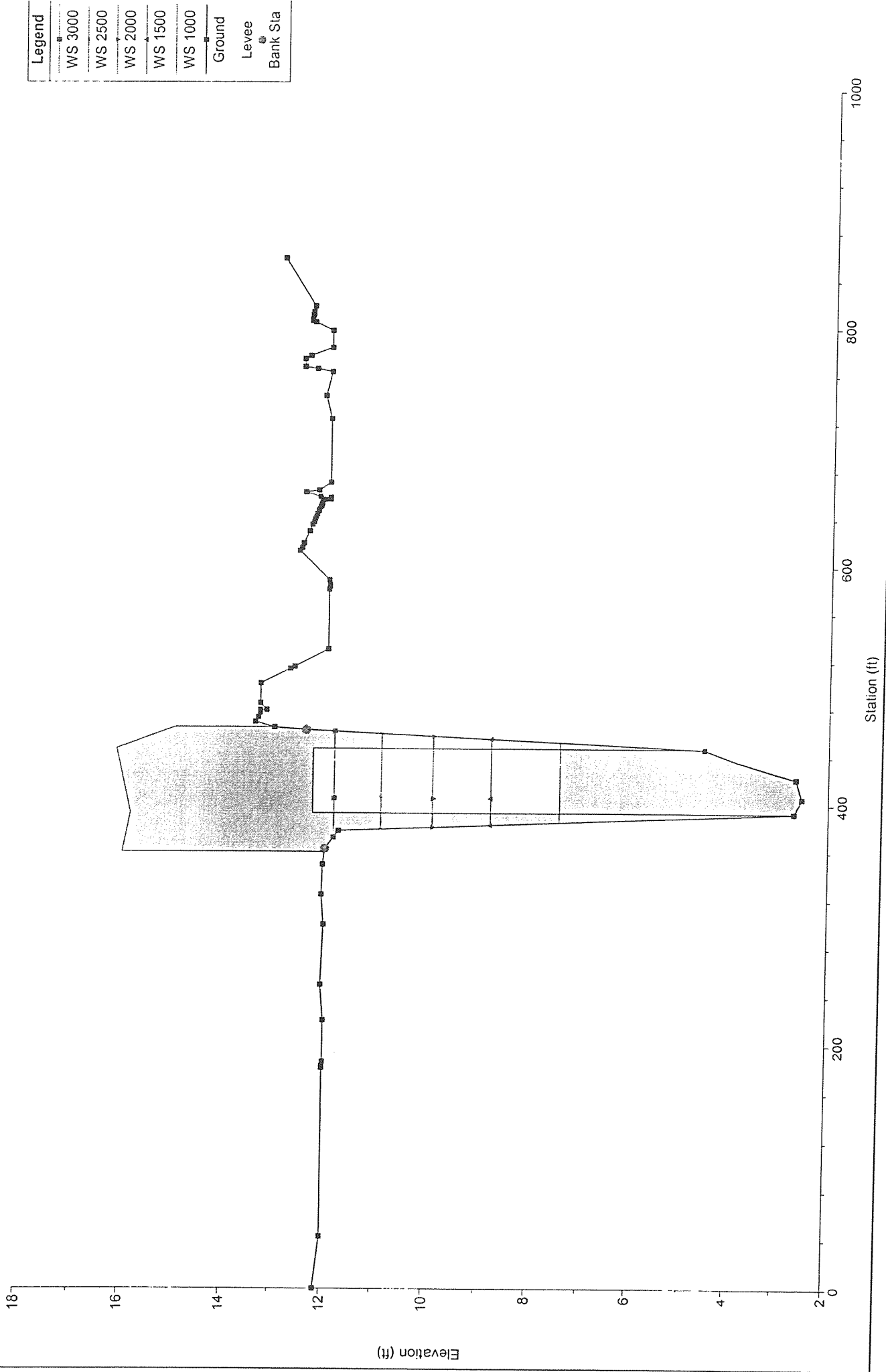

Sycamore Creek Plan: EXISTING-WITH BRIDGES 3/10/2003  
 RS = 359.426 CABRILLO BRIDGE - DOWNSTREAM SIDE - RS 359

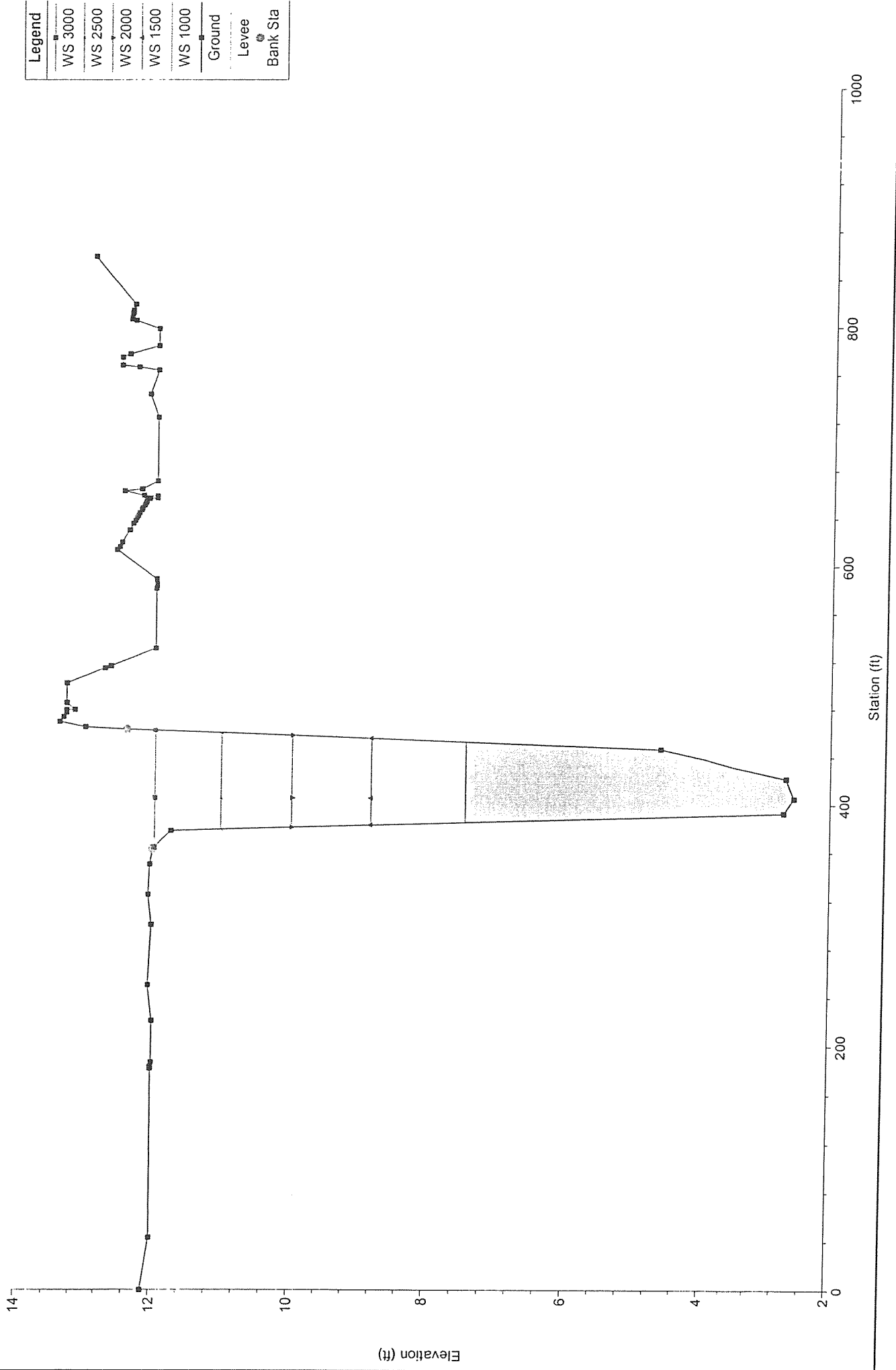

Legend	
—■—	WS 3000
—■—	WS 2500
—■—	WS 2000
—■—	WS 1500
—■—	WS 1000
—■—	Ground
—○—	Levee
—■—	Bank Sta

Sycamore Creek Plan: EXISTING-WITH BRIDGES 3/10/2003  
 RS = 344.409 EAST BEACH PEDESTRIAN BRIDGE - UPSTREAM SIDE - RS 344

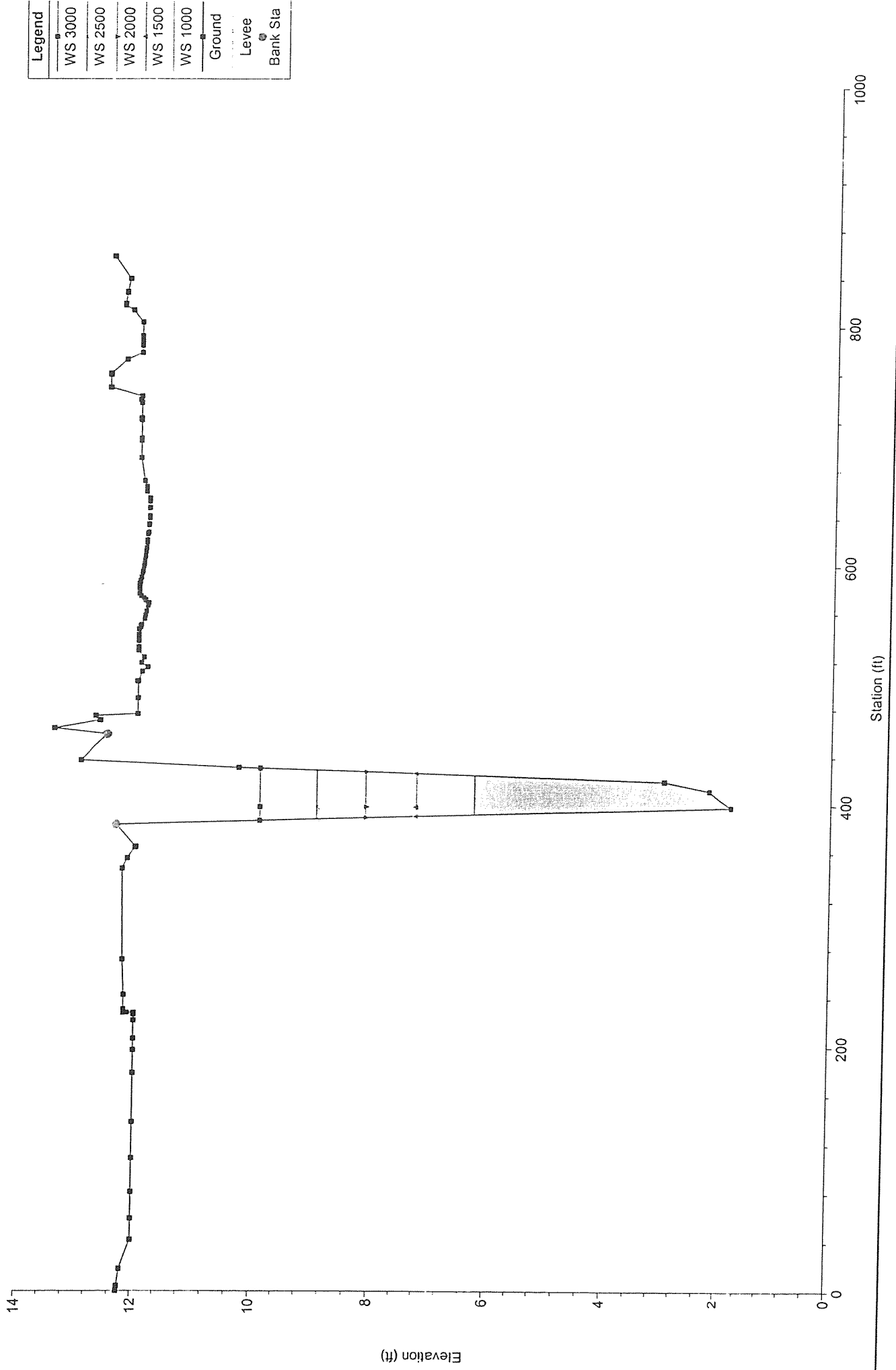

Legend	
—■—	WS 3000
—■—	WS 2500
—■—	WS 2000
—■—	WS 1500
—■—	WS 1000
—	Ground
- - -	Levee
○	Bank Sta

Sycamore Creek Plan: EXISTING-WITH BRIDGES 3/10/2003  
 RS = 334.5 BR EAST BEACH PEDESTRIAN BRIDGE (G)

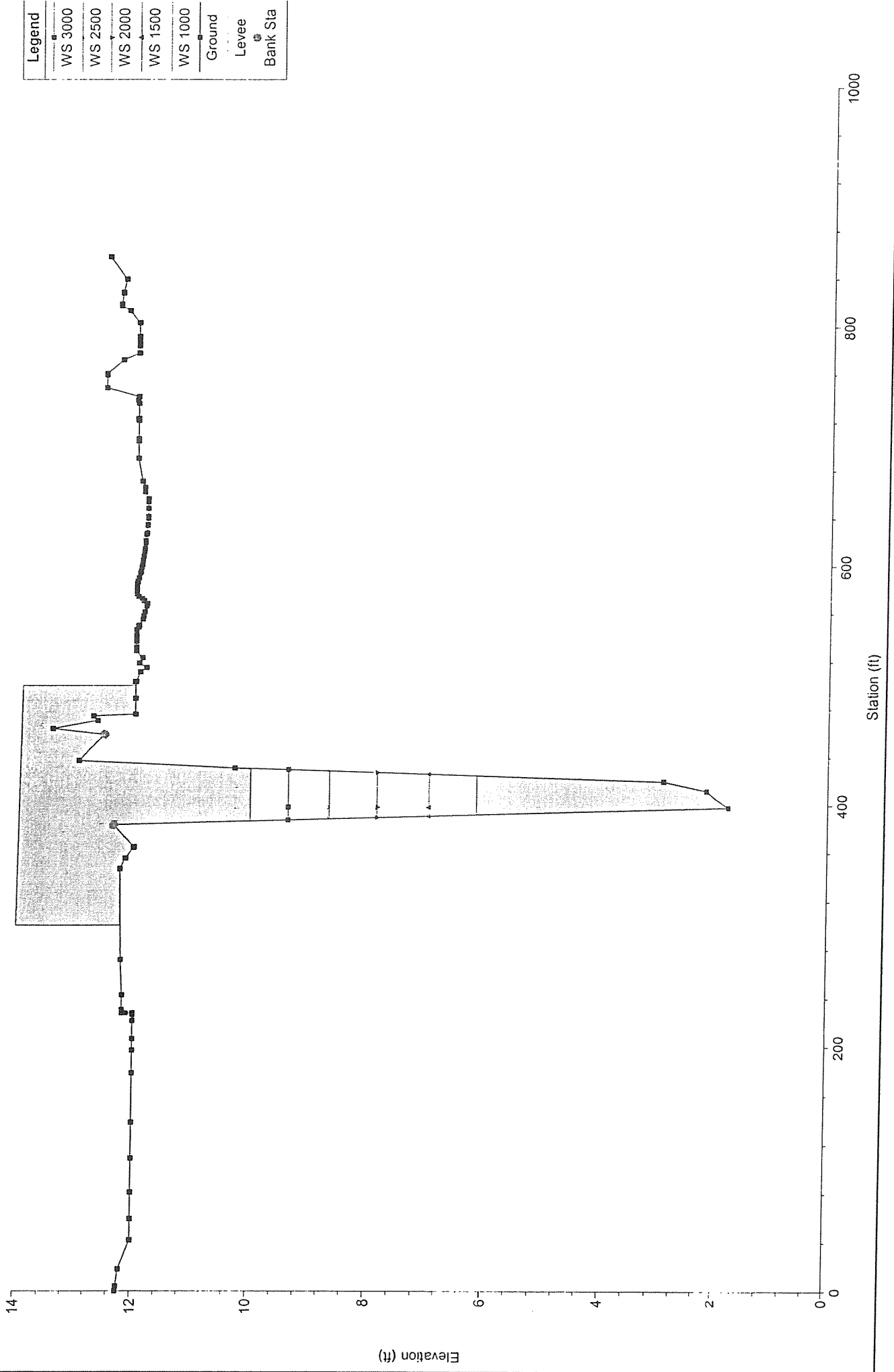

Sycamore Creek Plan: EXISTING-WITH BRIDGES 3/10/2003  
 RS = 334.5 BR EAST BEACH PEDESTRIAN BRIDGE (G)

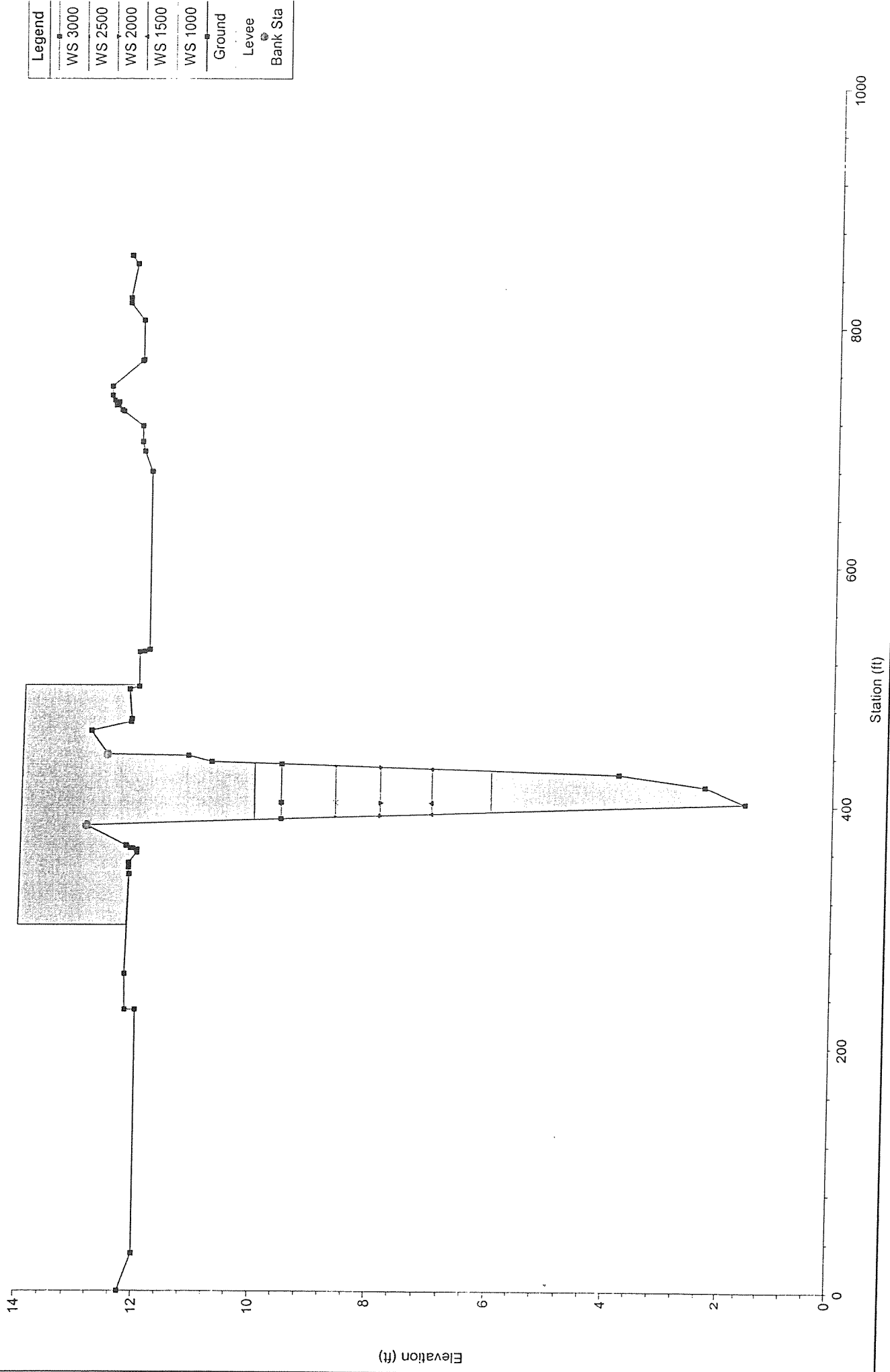

Sycamore Creek Plan: EXISTING-WITH BRIDGES 3/10/2003  
 RS = 334,409 EAST BEACH PEDESTRIAN BRIDGE - DOWNSTREAM SIDE - RS 334

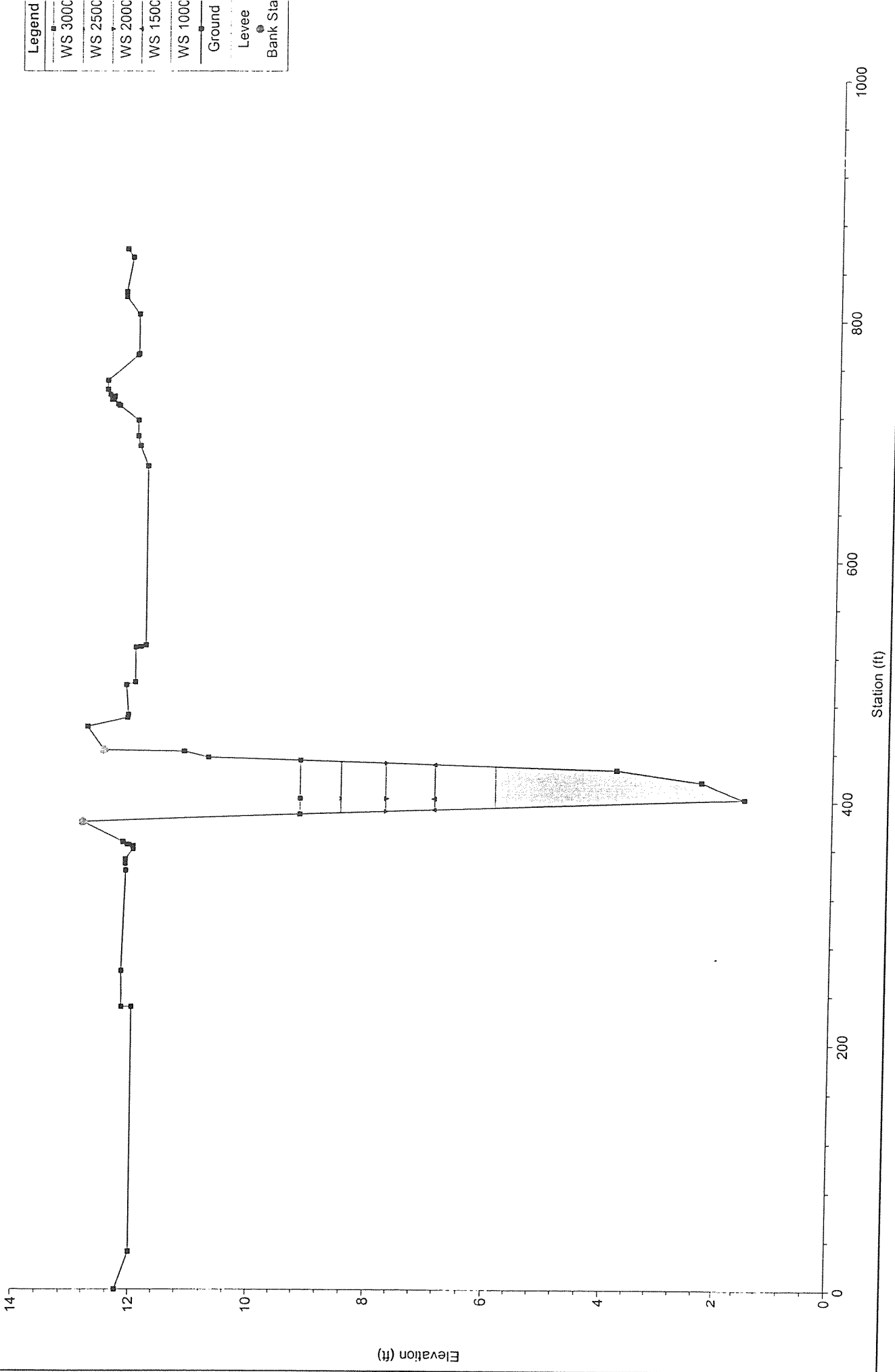

**HEC-RAS Cross Sections and Profiles  
For Master Plan Analysis**



Project Number: 14643.01  
 Description: SYCAMORE CREEK  
 Client: County Flood Control  
 Date: 10/29/2003  
 File: 14643CAPACITIES-MASTERPLAN.xls

Prepared By:

Penfield Smith  
 P.O. Box 98  
 Santa Barbara, CA 93102  
 (805)963-9532

REACH #	REACH NAME	RIVER STATION RANGE	CAPACITY
1	East Beach Pedestrian Bridge	334 to 344	5,500
2	Cabrillo Blvd Bridge	344 to 465	5,000
3	Between Cabrillo and Por La Mar Circle #1	604	5,500
4	Por La Mar Circle Bridge #1	710 to 755	5,500
5	Between Por La Mar Circle #1 and #2	932	4,500
6	Por La Mar Circle Bridge #2	1110 to 1161	3,500
7	Between Por La Mar Circle #2 and Zoo	1214	4,000
8	Zoo Bridge	1270 to 1328	3,000
9	Between Zoo and Railroad	1510	3,000
10	Railroad Bridge	1652 to 1674	5,000
11	101 Bridge	1723 to 1831	3,000
12	Between 101 and Punta Gorda	2051	3,000
13	Punta Gorda Bridge	2144 to 2181	3,000
14	Between Punta Gorda and Indio Muerto	2294 to 2529	3,500
15	Indio Muerto Bridge	2729 to 2773	3,500
16	Between Indio Muerto and Cacique Street	2805 to 3198	3,500
17	Cacique Street Bridge	3277 to 3287	4,500
18	Between Cacique and Carpinteria	3792 to 3837	7,000
19	Carpinteria Bridge	3914 to 3953	5,500
20	Between Carpinteria and Quinientos	4018 to 4322	6,000
21	Quinientos Bridge	4440 to 4484	6,000
22	Between Quinientos and Mason	4574 to 5021	6,000
23	Mason Street Bridge	5112 to 5150	4,000
24	Between Mason and Yanonali	5300 to 5535	3,500
25	Yanonali Bridge	6139 to 6167	3,000

Legend  
WS 30  
Ground

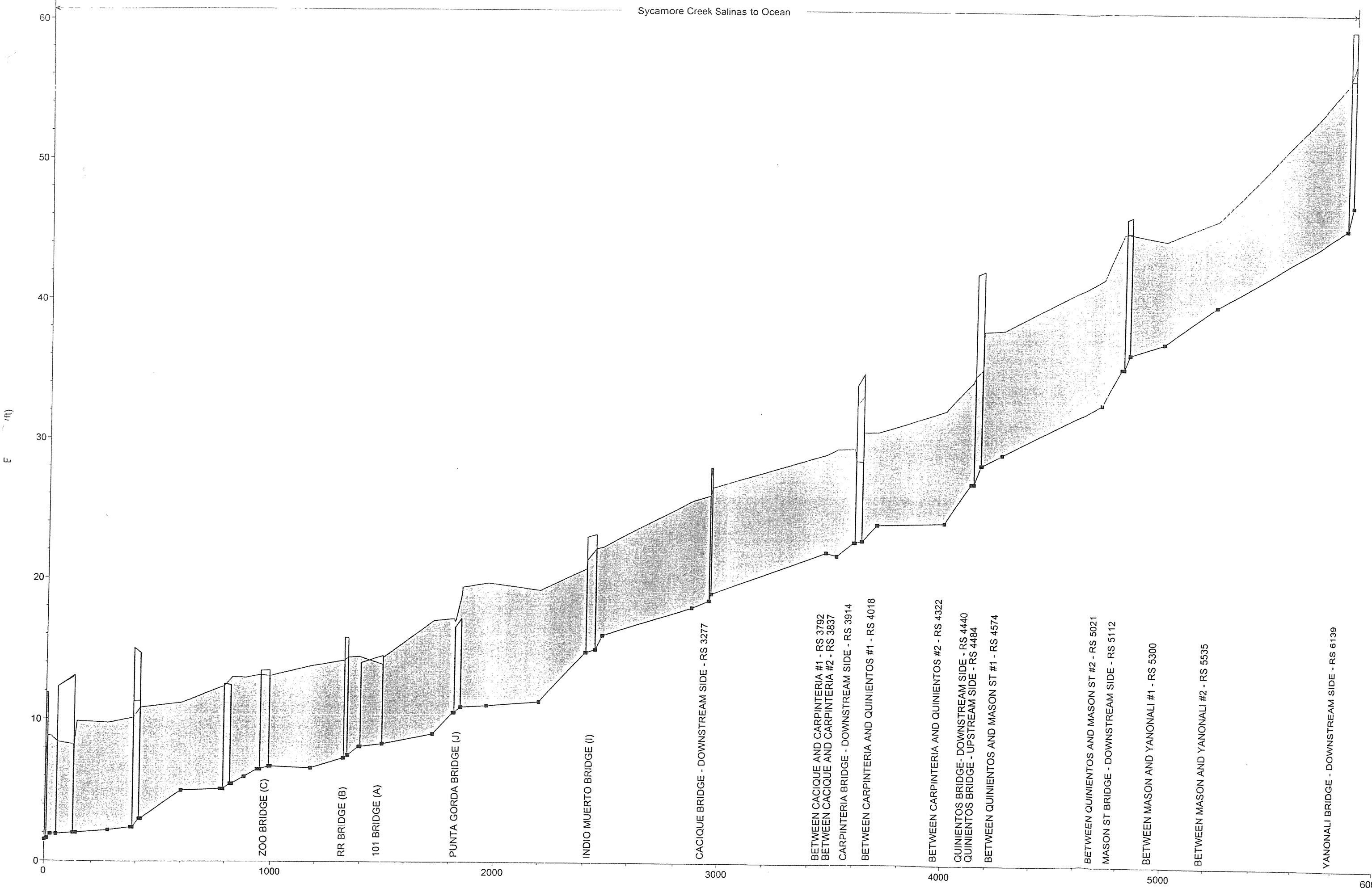

ZOO BRIDGE (C)

RR BRIDGE (B)

101 BRIDGE (A)

PUNTA GORDA BRIDGE (J)

INDIO MUERTO BRIDGE (I)

CACIQUE BRIDGE - DOWNSTREAM SIDE - RS 3277

BETWEEN CACIQUE AND CARPINTERIA #1 - RS 3792

BETWEEN CACIQUE AND CARPINTERIA #2 - RS 3837

CARPINTERIA BRIDGE - DOWNSTREAM SIDE - RS 3914

BETWEEN CARPINTERIA AND QUINIENTOS #1 - RS 4018

BETWEEN CARPINTERIA AND QUINIENTOS #2 - RS 4322

QUINIENTOS BRIDGE - DOWNSTREAM SIDE - RS 4440

QUINIENTOS BRIDGE - UPSTREAM SIDE - RS 4484

BETWEEN QUINIENTOS AND MASON ST #1 - RS 4574

BETWEEN QUINIENTOS AND MASON ST #2 - RS 5021

MASON ST BRIDGE - DOWNSTREAM SIDE - RS 5112

BETWEEN MASON AND YANONALI #1 - RS 5300

BETWEEN MASON AND YANONALI #2 - RS 5535

YANONALI BRIDGE - DOWNSTREAM SIDE - RS 6139



Sycamore Creek Plan: MASTER PLAN CAPACITY RUN 10/29/2003  
RS = 334.5 BR EAST BEACH PEDESTRIAN BRIDGE (G)



Sycamore Creek Plan: MASTER PLAN CAPACITY RUN 10/29/2003  
RS = 334.5 BR EAST BEACH PEDESTRIAN BRIDGE (G)

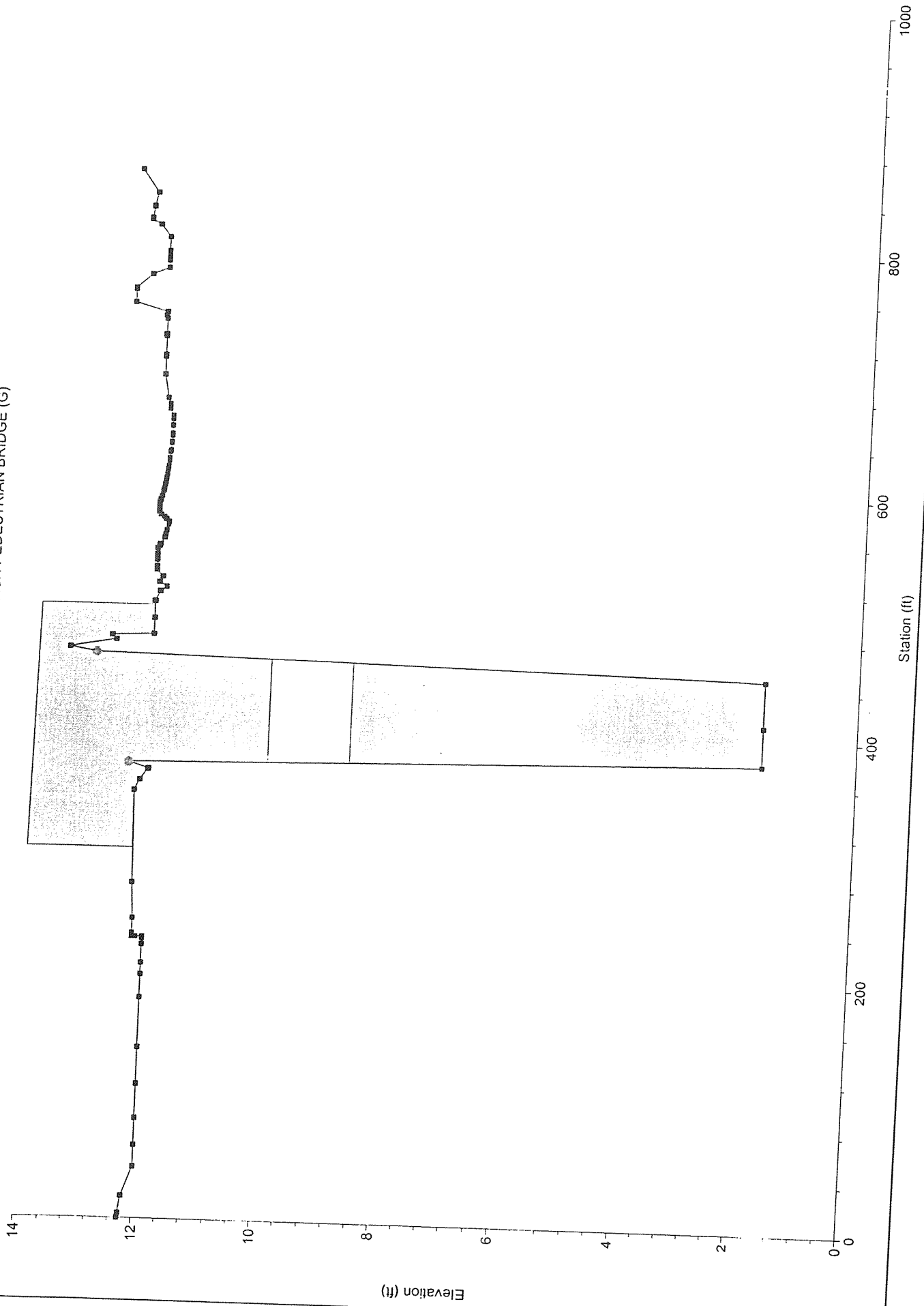

Sycamore Creek Plan: MASTER PLAN CAPACITY RUN 10/29/2003  
RS = 344.409 EAST BEACH PEDESTRIAN BRIDGE - UPSTREAM SIDE - RS 344

Legend	
WS 300	Ground
Levee	Bank Sta

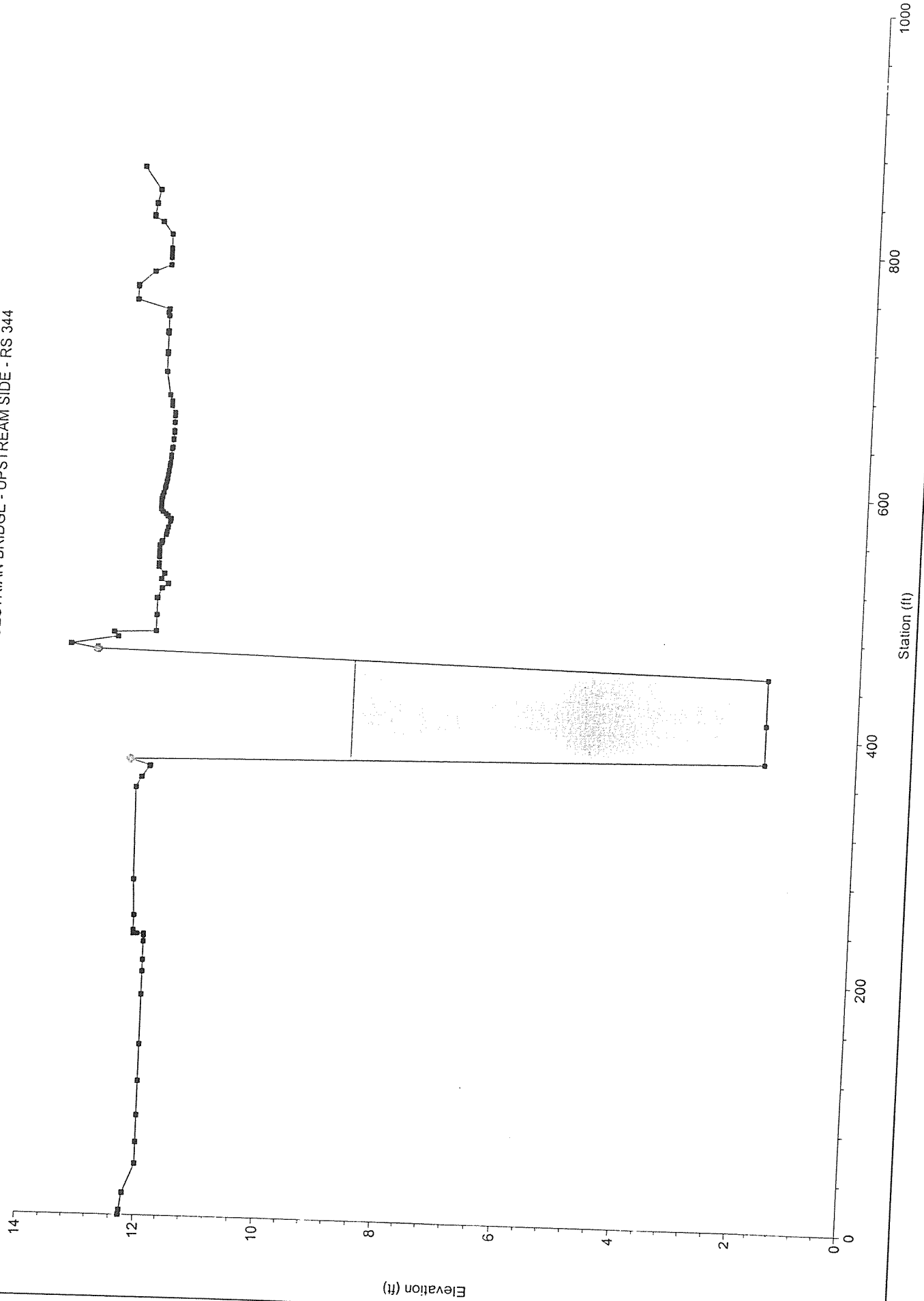

Sycamore Creek Plan: MASTER PLAN CAPACITY RUN 10/29/2003  
RS = 359.426 CABRILLO BRIDGE - DOWNSTREAM SIDE - RS 359

Legen	
WS 300	Ground
Levee	Bank St

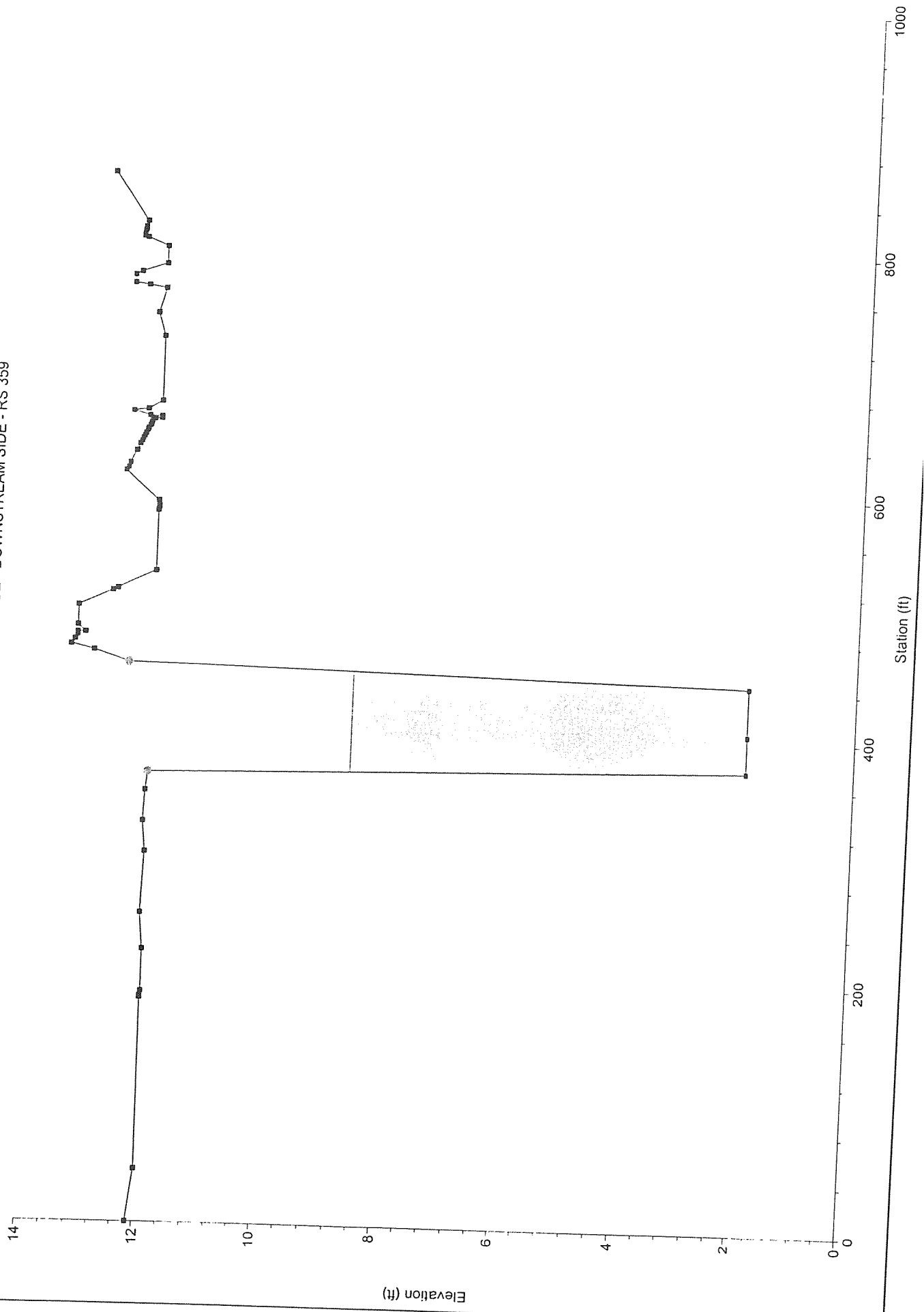

Sycamore Creek Plan: MASTER PLAN CAPACITY RUN 10/29/2003  
RS = 384 BR CABRILLO BLVD BRIDGE (F)

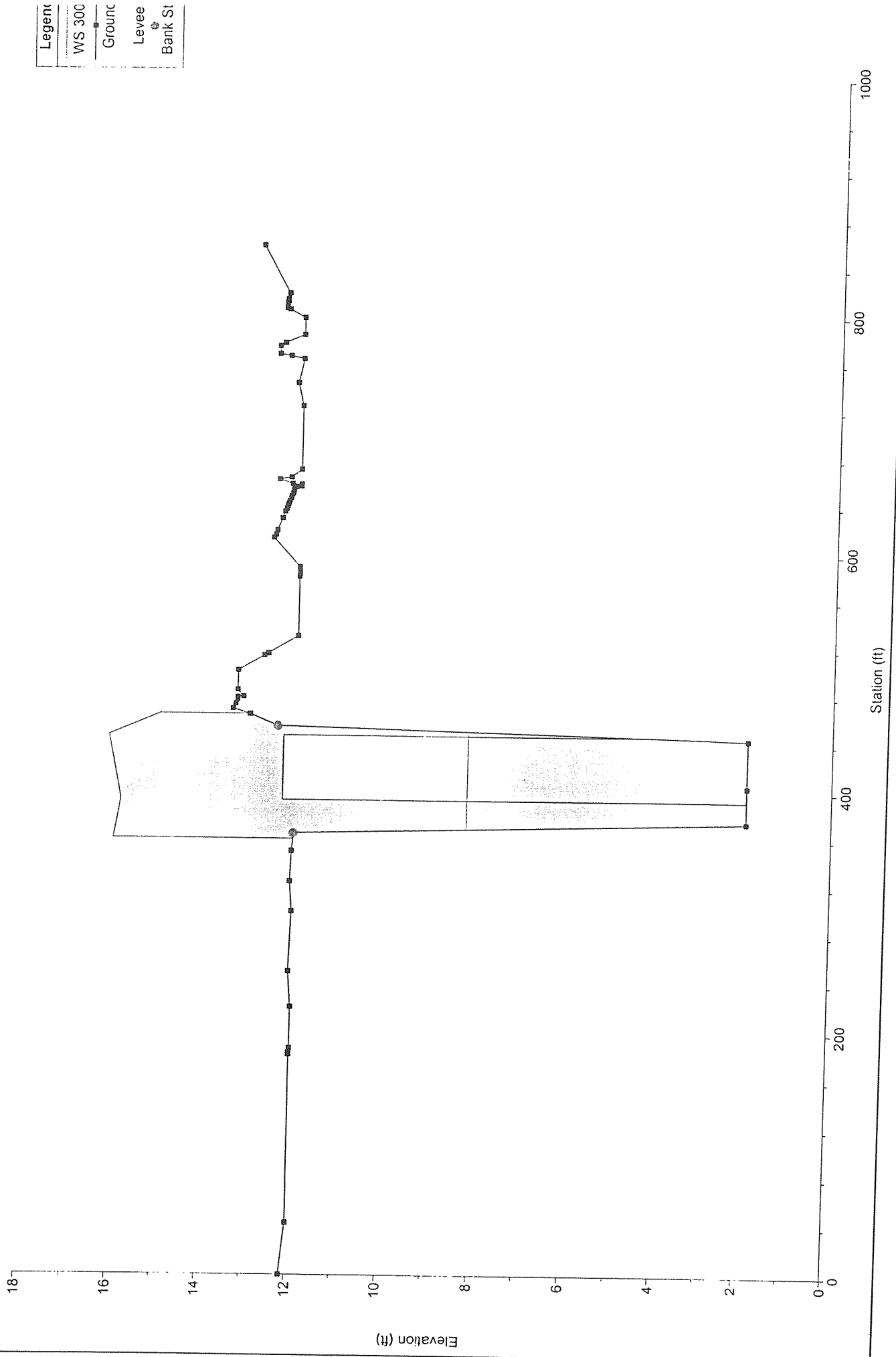

Legend	
WS 300	Ground
Levee	Levee
Bank St	Bank St



Sycamore Creek Plan: MASTER PLAN CAPACITY RUN 10/29/2003  
RS = 384 BR CABRILLO BLVD BRIDGE (F)

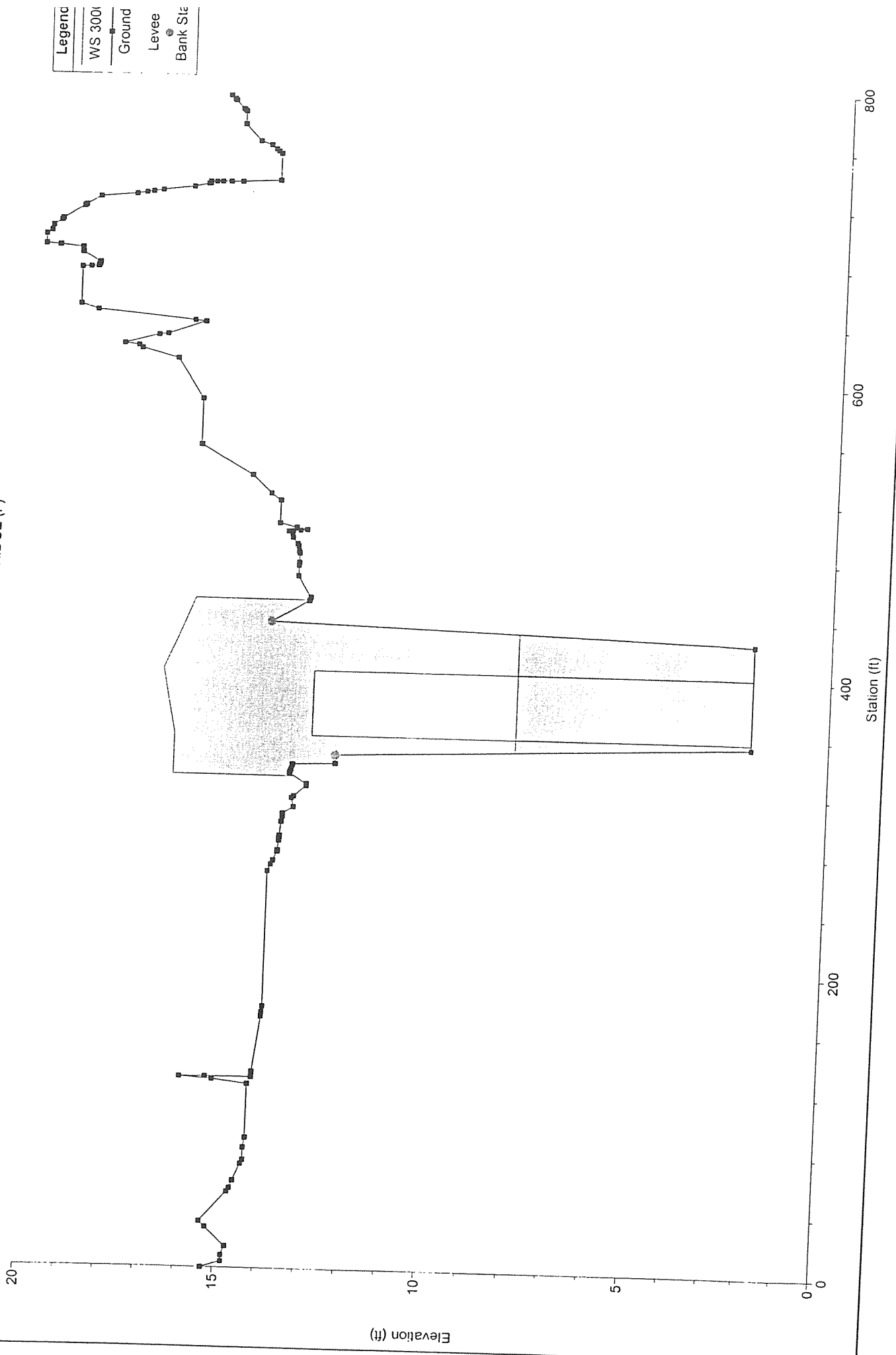

Sycamore Creek Plan: MASTER PLAN CAPACITY RUN 10/29/2003  
RS = 465.300 CABRILLO BRIDGE - UPSTREAM SIDE - RS 465

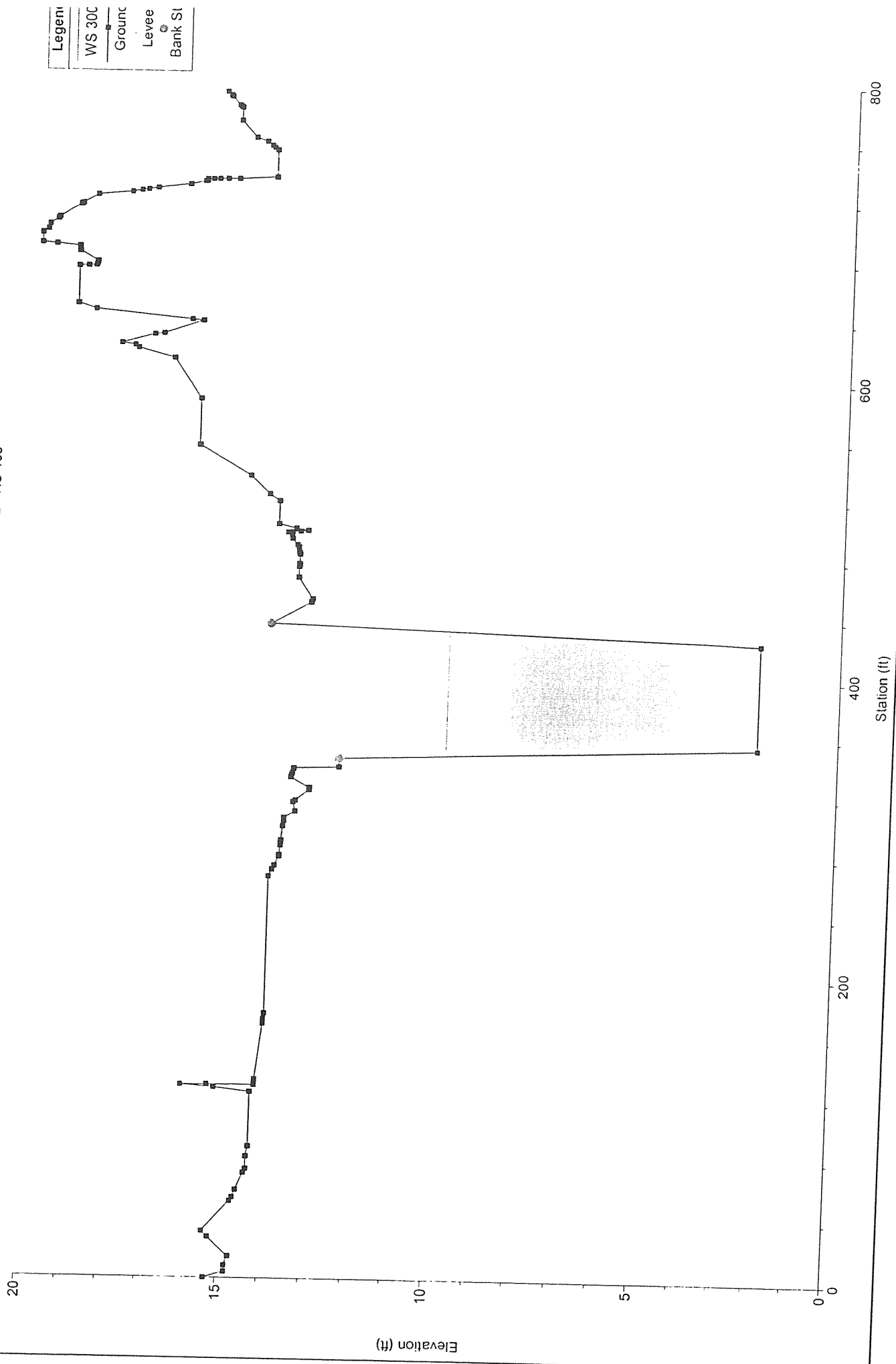

Legend	
WS 30C	—
Ground	—
Levee	—
Bank St	○

Sycamore Creek Plan: MASTER PLAN CAPACITY RUN 10/29/2003  
 RS = 604.965 BETWEEN CABRILLO AND POR LA MAR #1 - RS 604

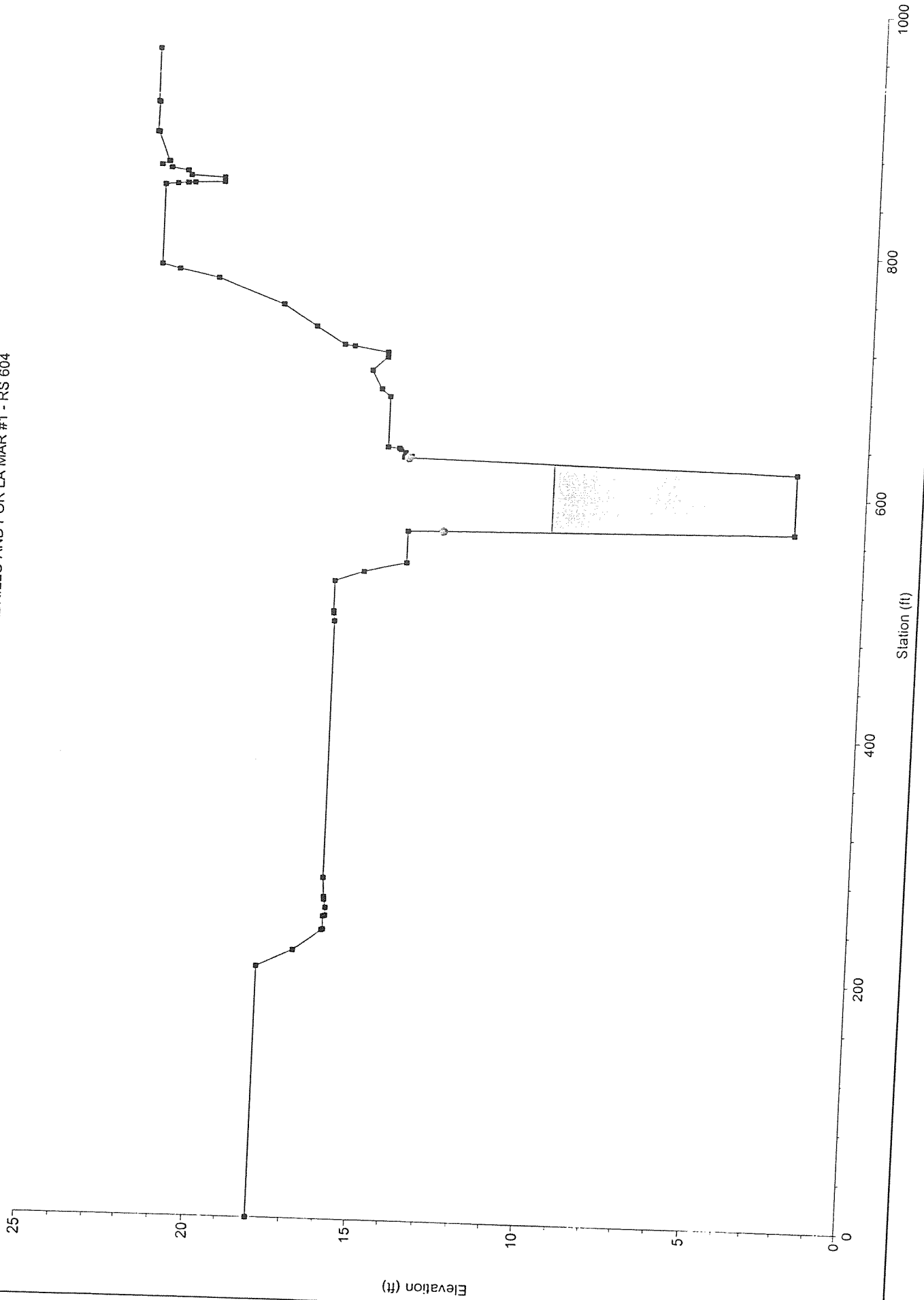

Legend	
WS 30C	Ground
Levee	Bank St

Sycamore Creek Plan: MASTER PLAN CAPACITY RUN 10/29/2003  
RS = 710.610 POR LA MAR CIRCLE #1 - DOWNSTREAM SIDE - RS 710

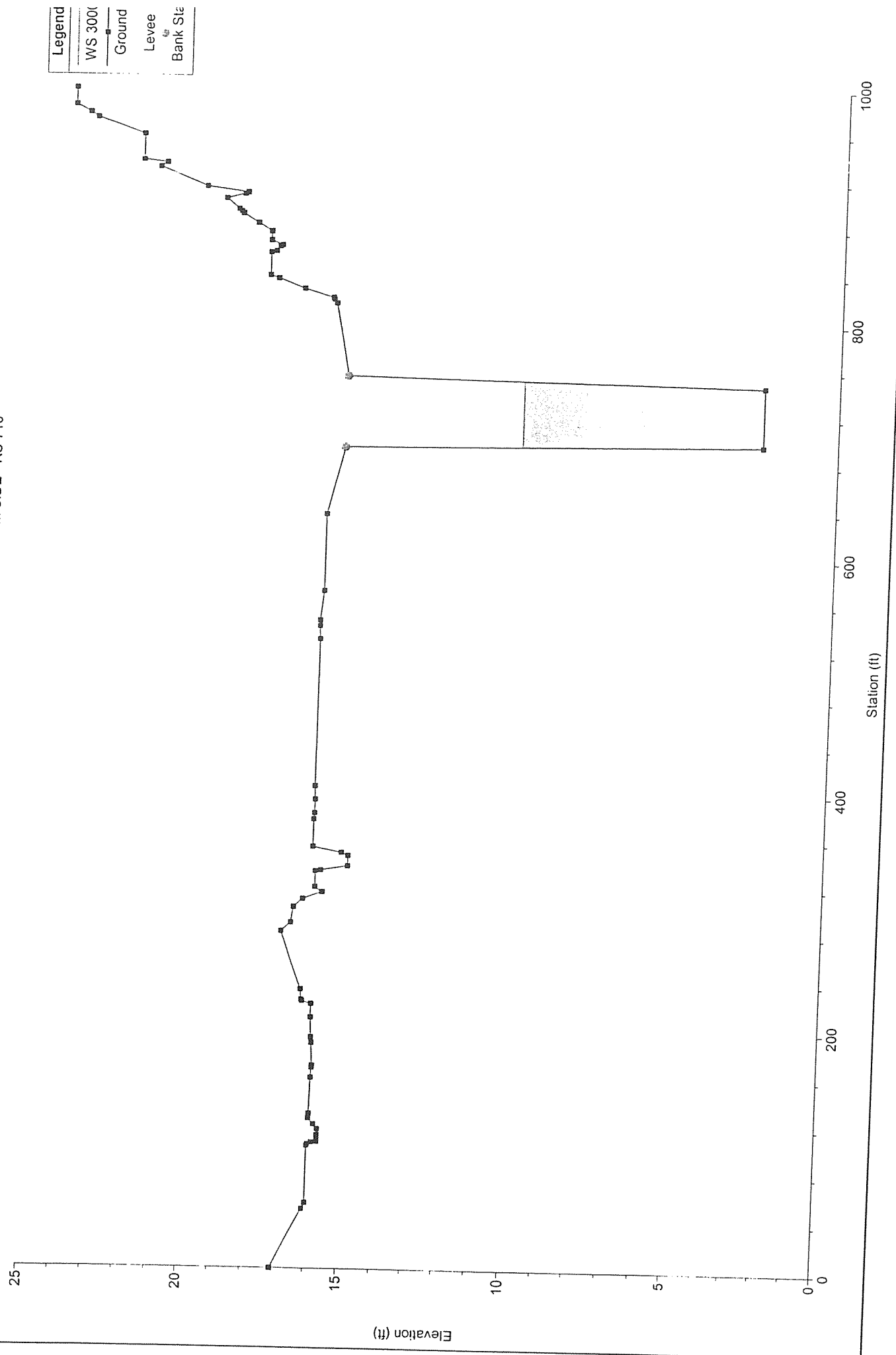

Sycamore Creek Plan: MASTER PLAN CAPACITY RUN 10/29/2003  
 RS = 718 BR POR LA MAR BRIDGE #1 (E)

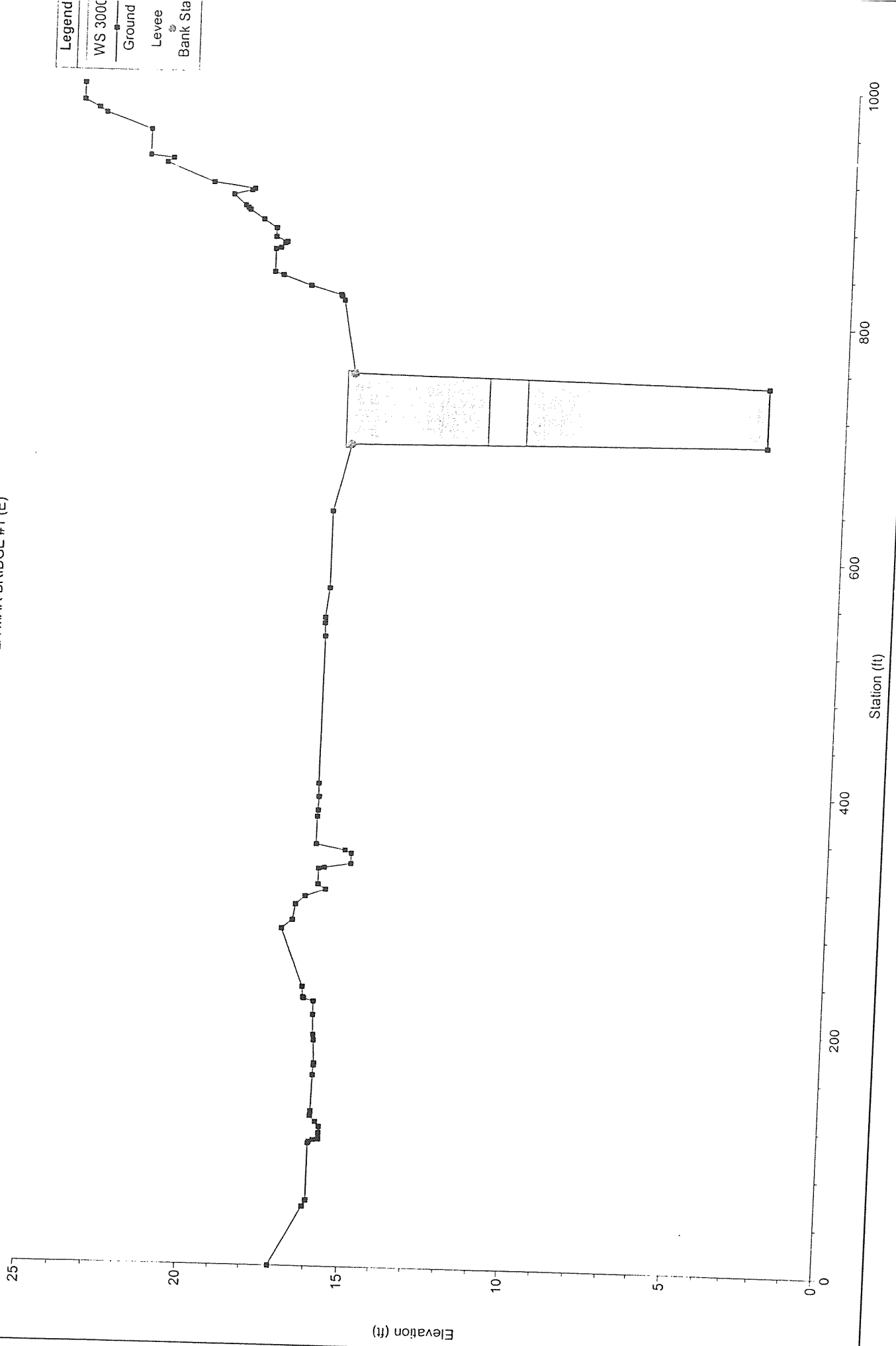

Sycamore Creek Plan: MASTER PLAN CAPACITY RUN 10/29/2003  
RS = 718 BR FOR LA MAR BRIDGE #1 (E)

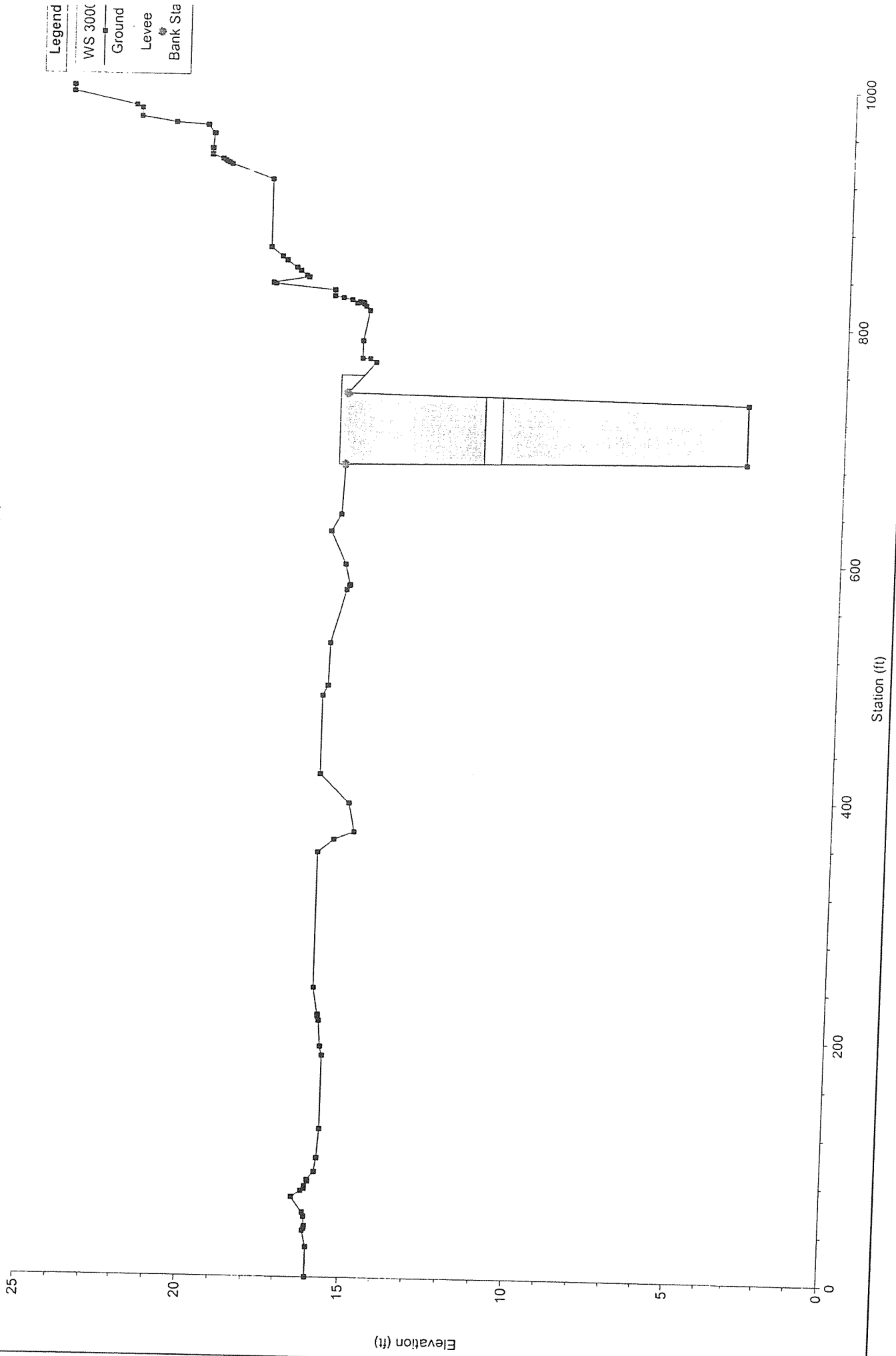

Legend  
WS 3000  
Ground  
Levee  
Bank Sta

Sycamore Creek Plan: MASTER PLAN CAPACITY RUN 10/29/2003  
RS = 755.267 POR LA MAR CIRCLE #1 - UPSTREAM SIDE - RS 755

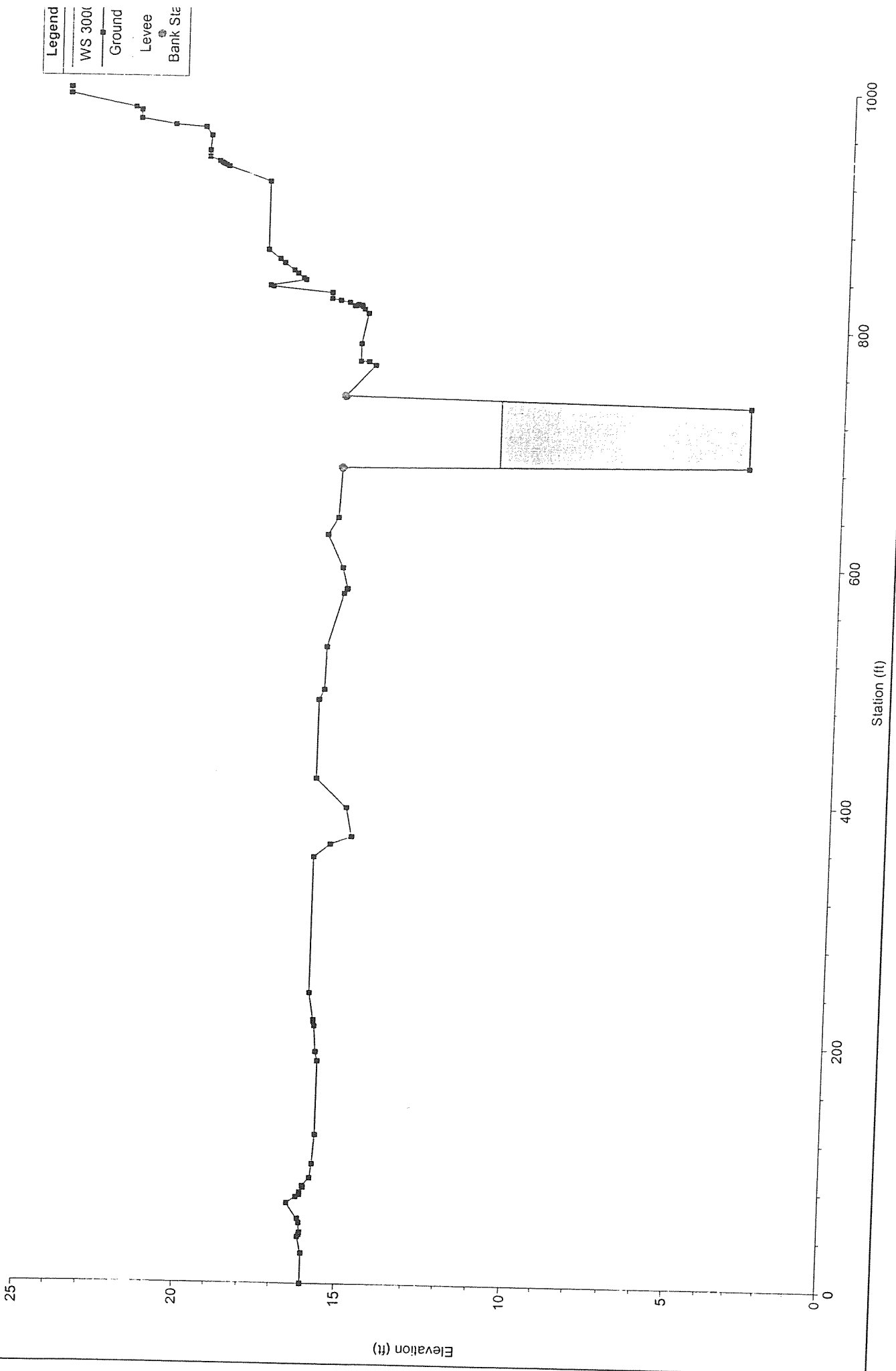

Legend  
WS 3000  
Ground  
Levee  
Bank Site

Sycamore Creek Plan: MASTER PLAN CAPACITY RUN 10/29/2003  
 RS = 932.393 BETWEEN POR LA MAR #1 AND #2 - RS 932

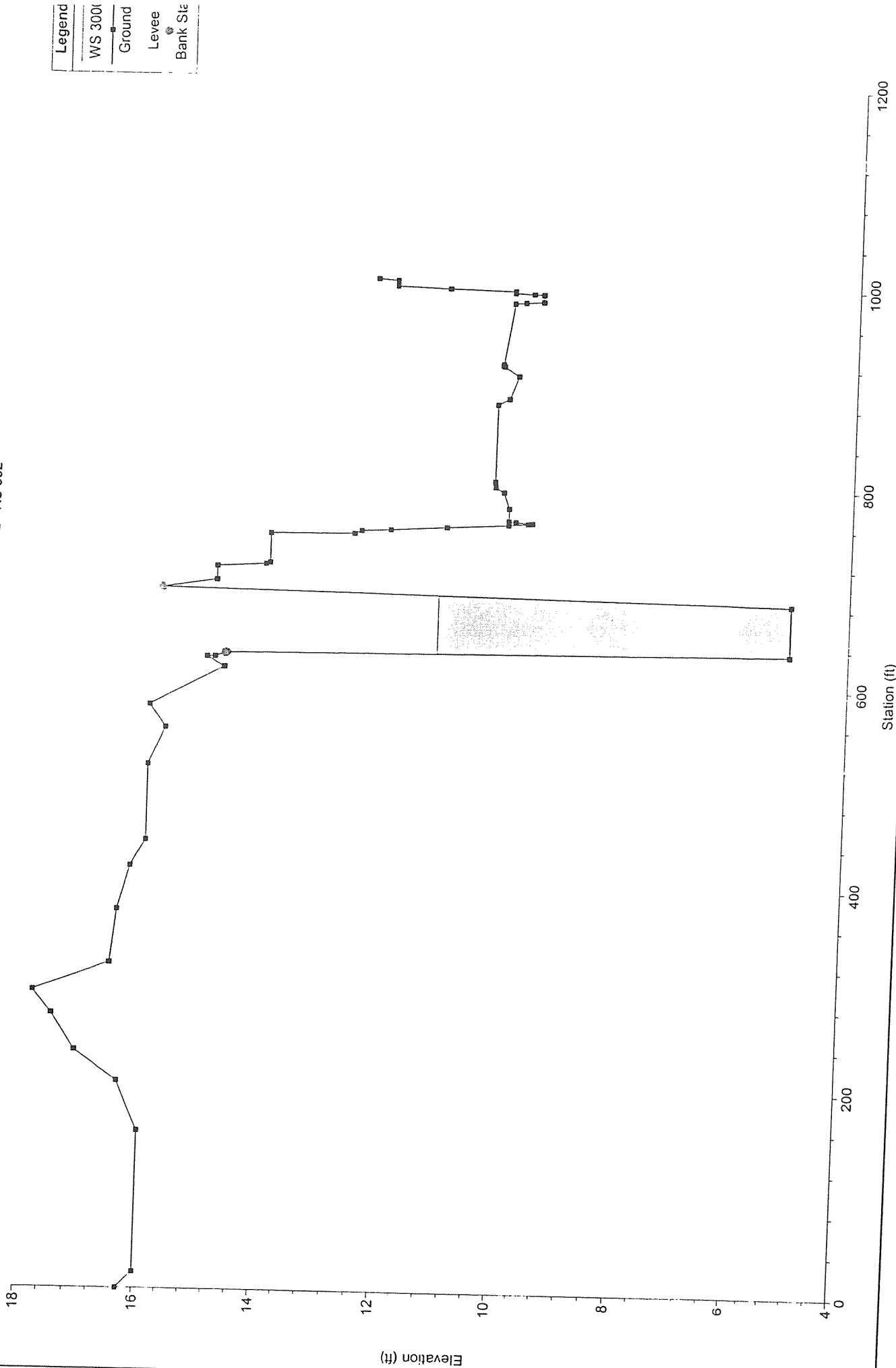

Legend	
WS 300'	
Ground	—■—
Levee	- - -■- - -
Bank Site	⊗



Sycamore Creek Plan: MASTER PLAN CAPACITY RUN 10/29/2003  
 RS = 1110.025 FOR LA MAR CIRCLE #2 - DOWNSTREAM SIDE - RS 1110

Legend	
WS 300C	Ground
	Levee
	Bank Sta

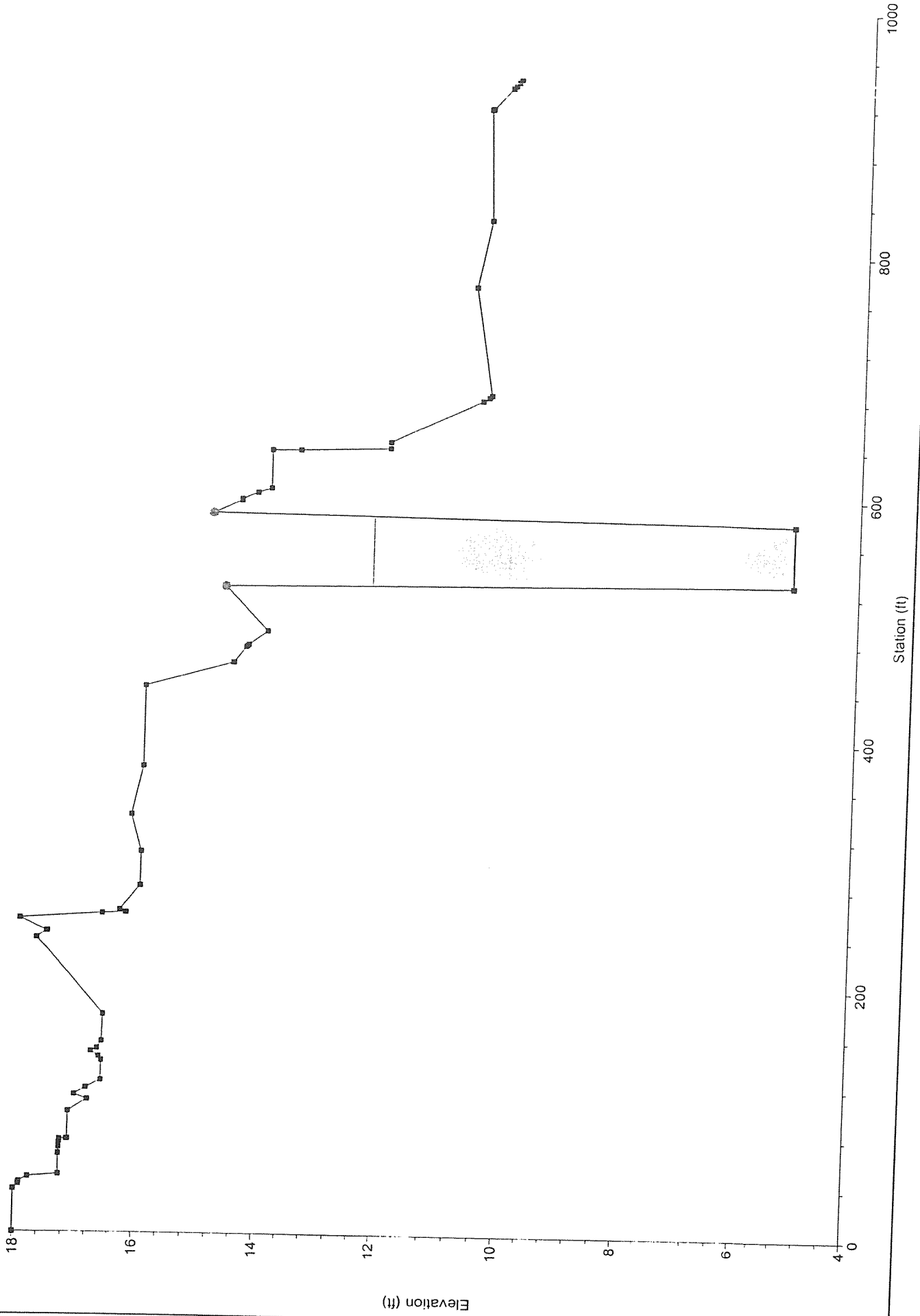

Sycamore Creek Plan: MASTER PLAN CAPACITY RUN 10/29/2003  
RS = 1123 BR POR LA MAR BRIDGE #2 (D)

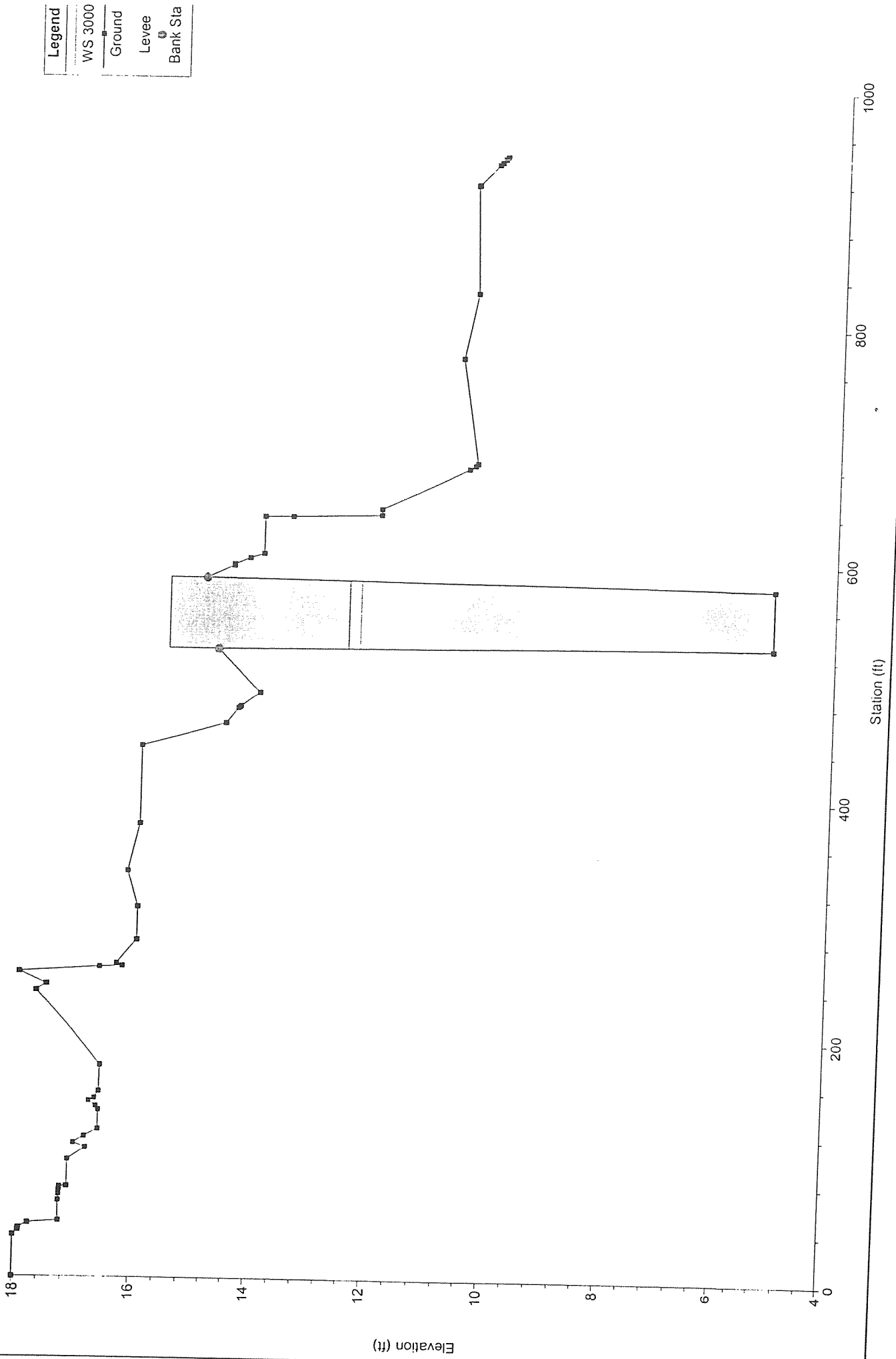

Sycamore Creek Plan: MASTER PLAN CAPACITY RUN 10/29/2003  
 RS = 1123 BR FOR LA MAR BRIDGE #2 (D)

Legend	
WS 3000	Ground
Levee	Bank Sta

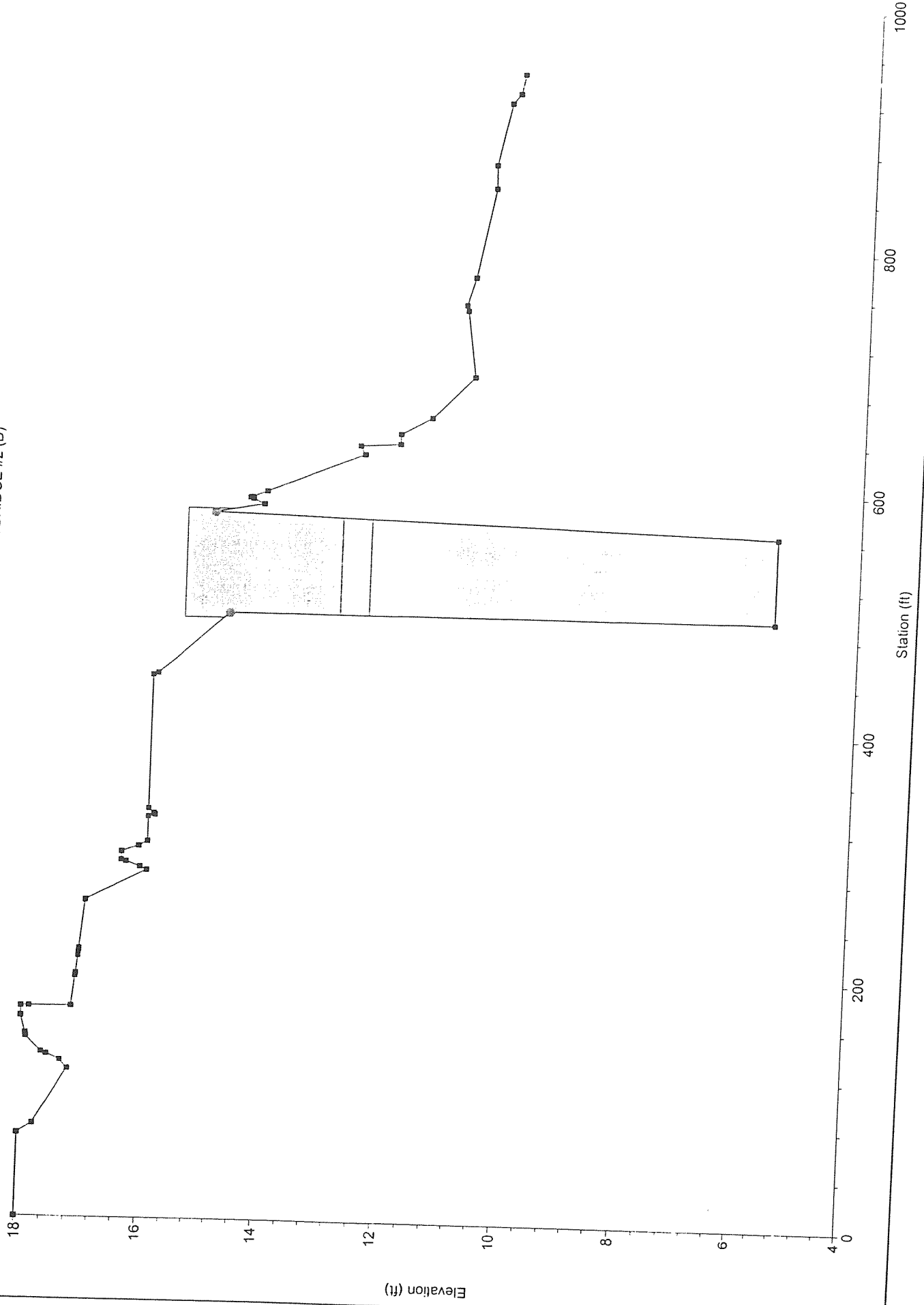

Sycamore Creek Plan: MASTER PLAN CAPACITY RUN 10/29/2003  
RS = 1161.097 FOR LA MAR CIRCLE #2 - UPSTREAM SIDE - RS 1161

Legend	
WS 3000	○
Ground	—
Levee	▭
Bank Sta	●

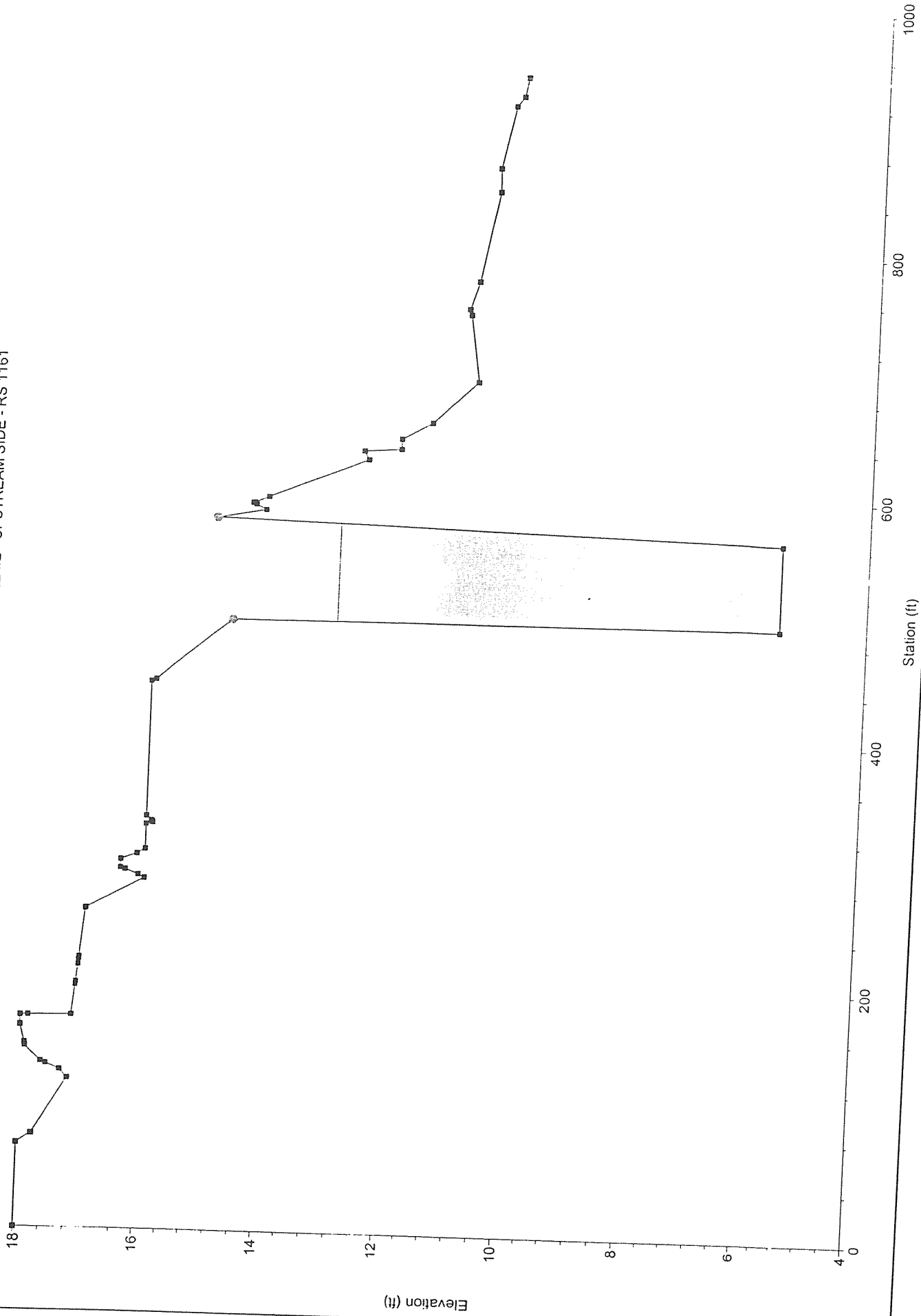

Sycamore Creek Plan: MASTER PLAN CAPACITY RUN 10/29/2003  
 RS = 1214.093 BETWEEN FOR LA MAR #2 AND ZOO - RS 1214

Legend	
WS 3000	
Ground	■
Levee	○
Bank Sta	●

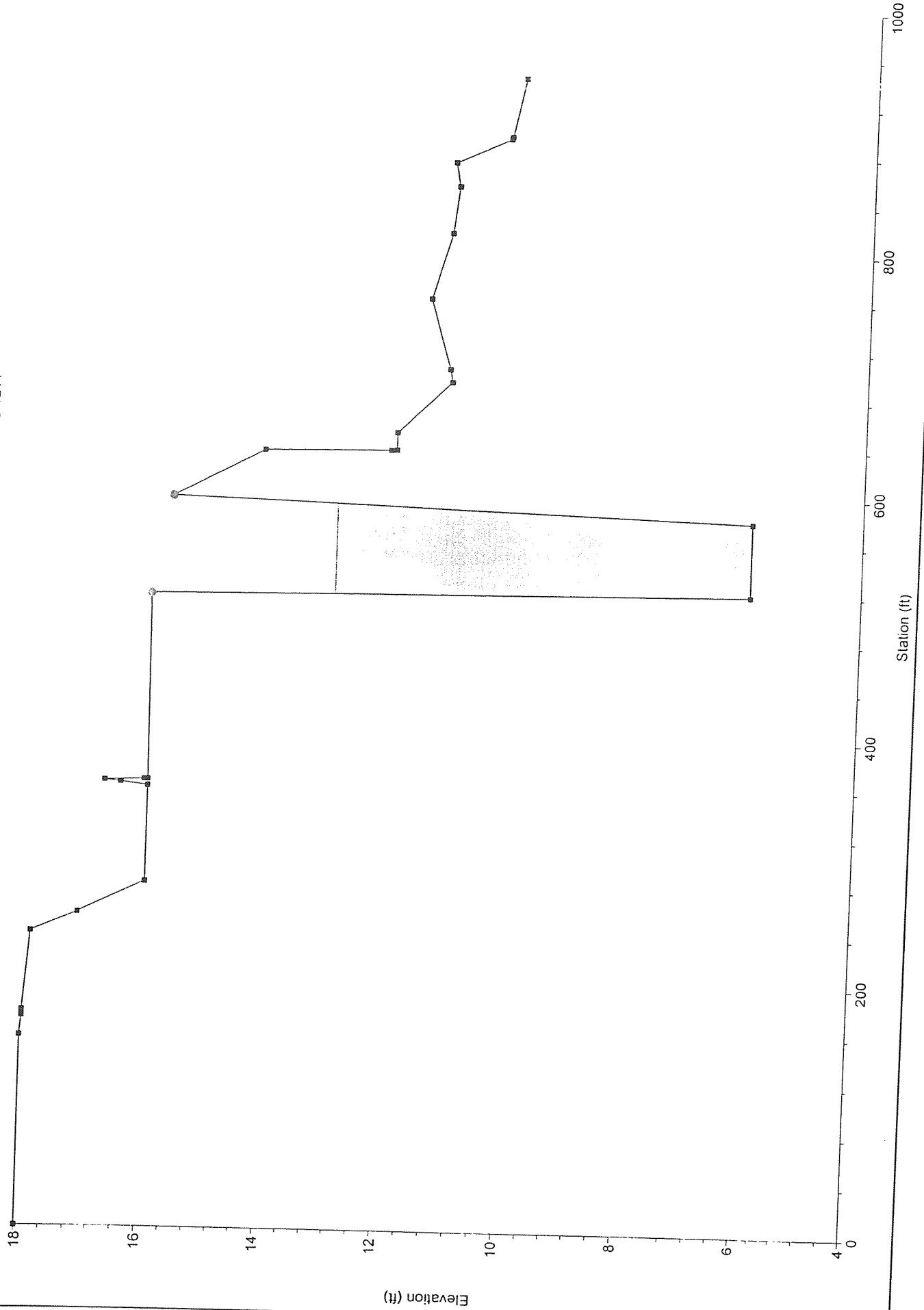

Sycamore Creek Plan: MASTER PLAN CAPACITY RUN 10/29/2003  
 RS = 1270.314 ZOO BRIDGE - DOWNSTREAM SIDE - RS 1270

Legend	
WS 3000	Ground
Levee	Bank Sta

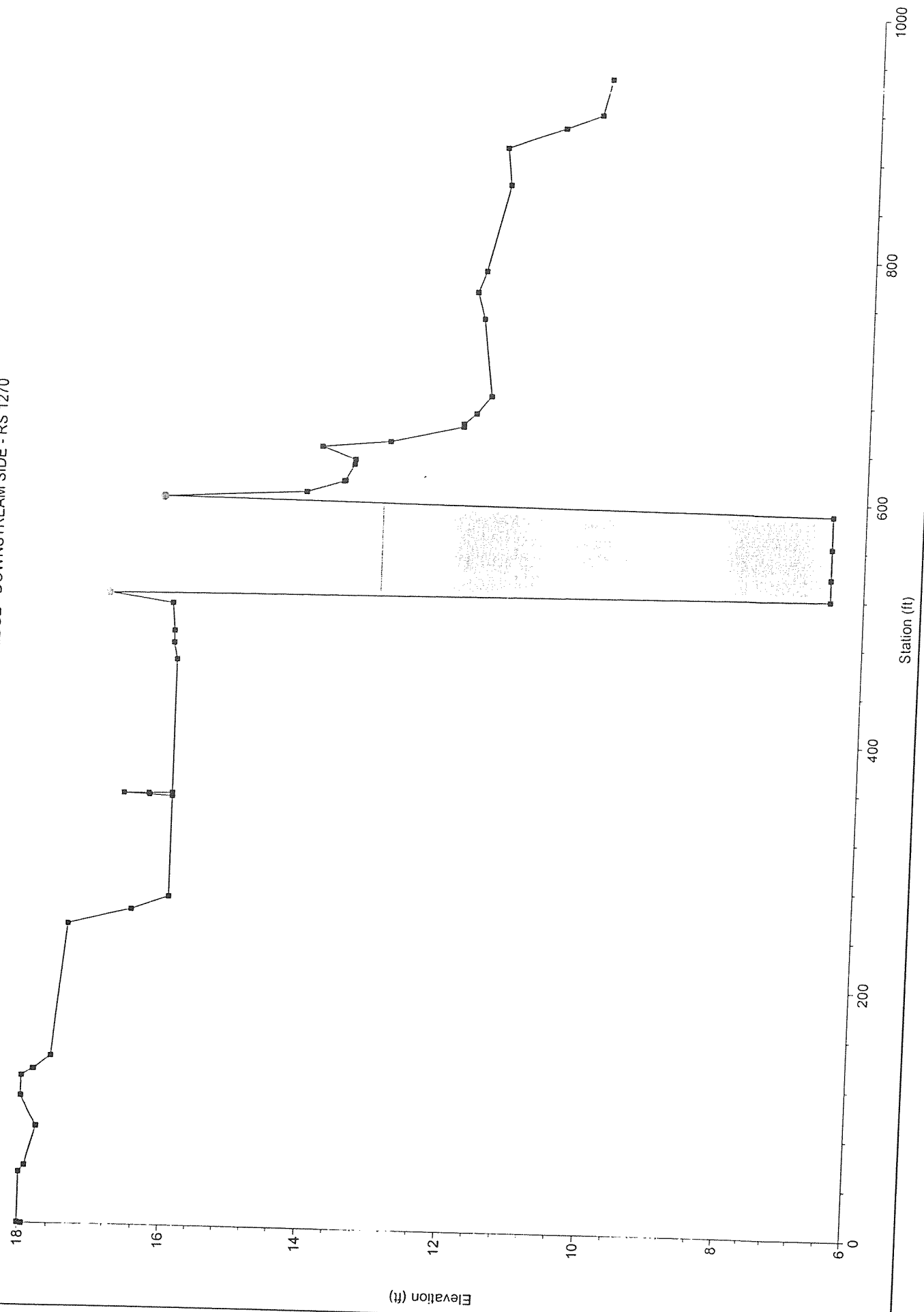

Sycamore Creek Plan: MASTER PLAN CAPACITY RUN 10/29/2003  
 RS = 1282 BR ZOO BRIDGE (C)

Legend	
WS 3000	—
Ground	■
Levee	□
Bank Sta	●

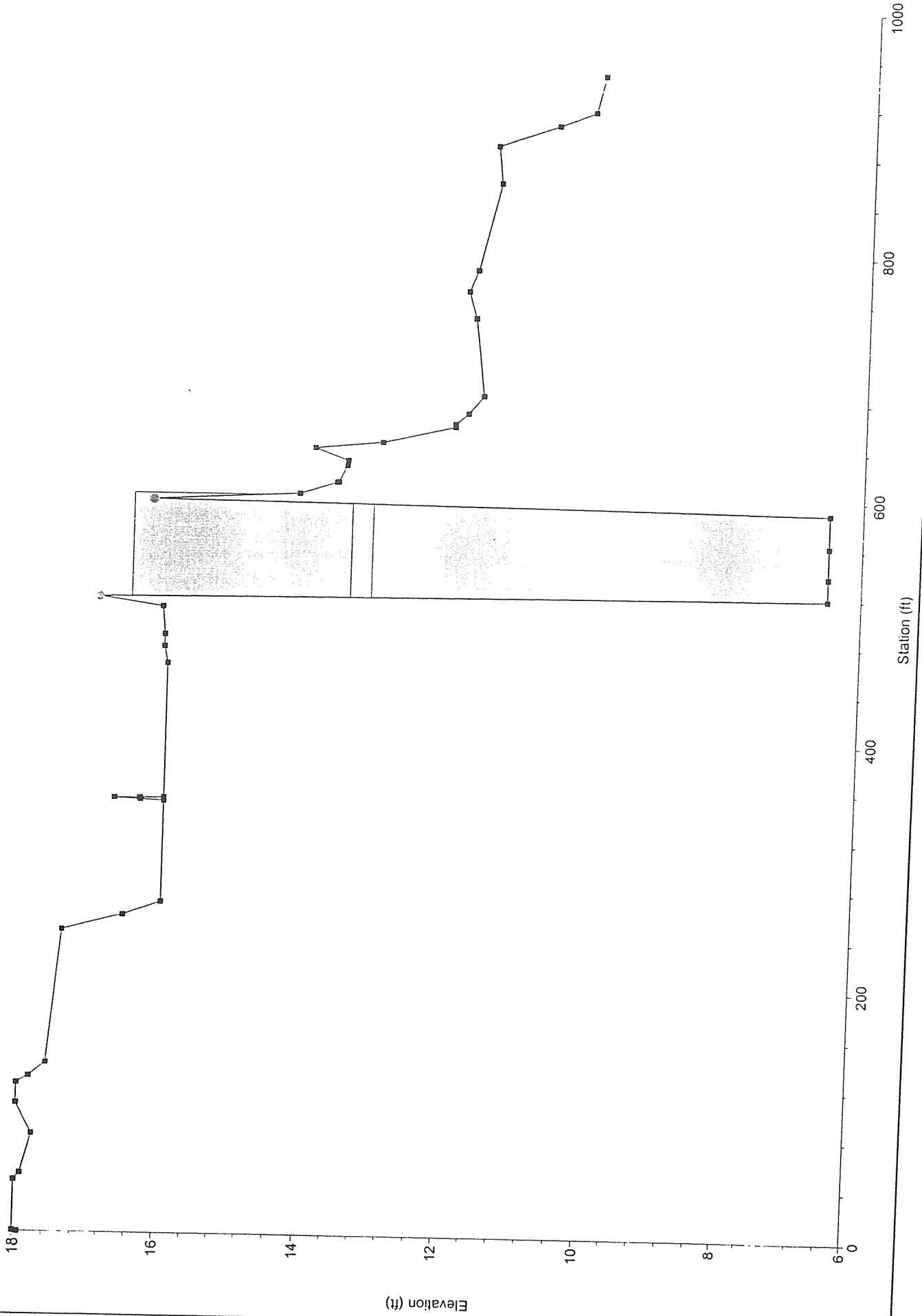

Sycamore Creek Plan: MASTER PLAN CAPACITY RUN 10/29/2003  
 RS = 1282 BR ZOO BRIDGE (C)

Legend	
WS 3000	Ground
Levee	Bank Sta

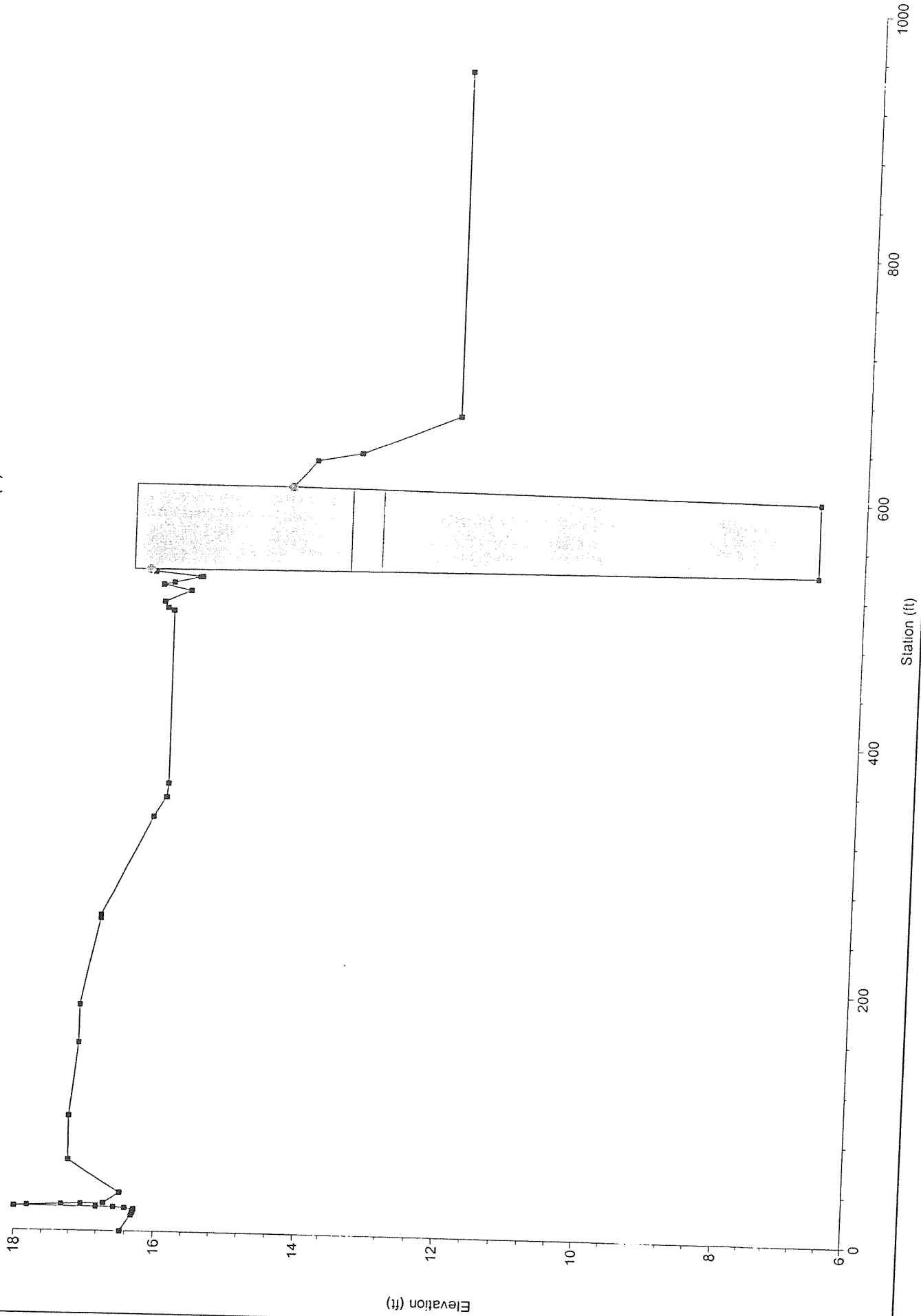

Elevation (ft)

Station (ft)



Sycamore Creek Plan: MASTER PLAN CAPACITY RUN 10/29/2003  
 RS = 1328.387 ZOO BRIDGE - UPSTREAM SIDE - RS 1328

Legend	
WS 3000	Ground
Levee	Bank Sta

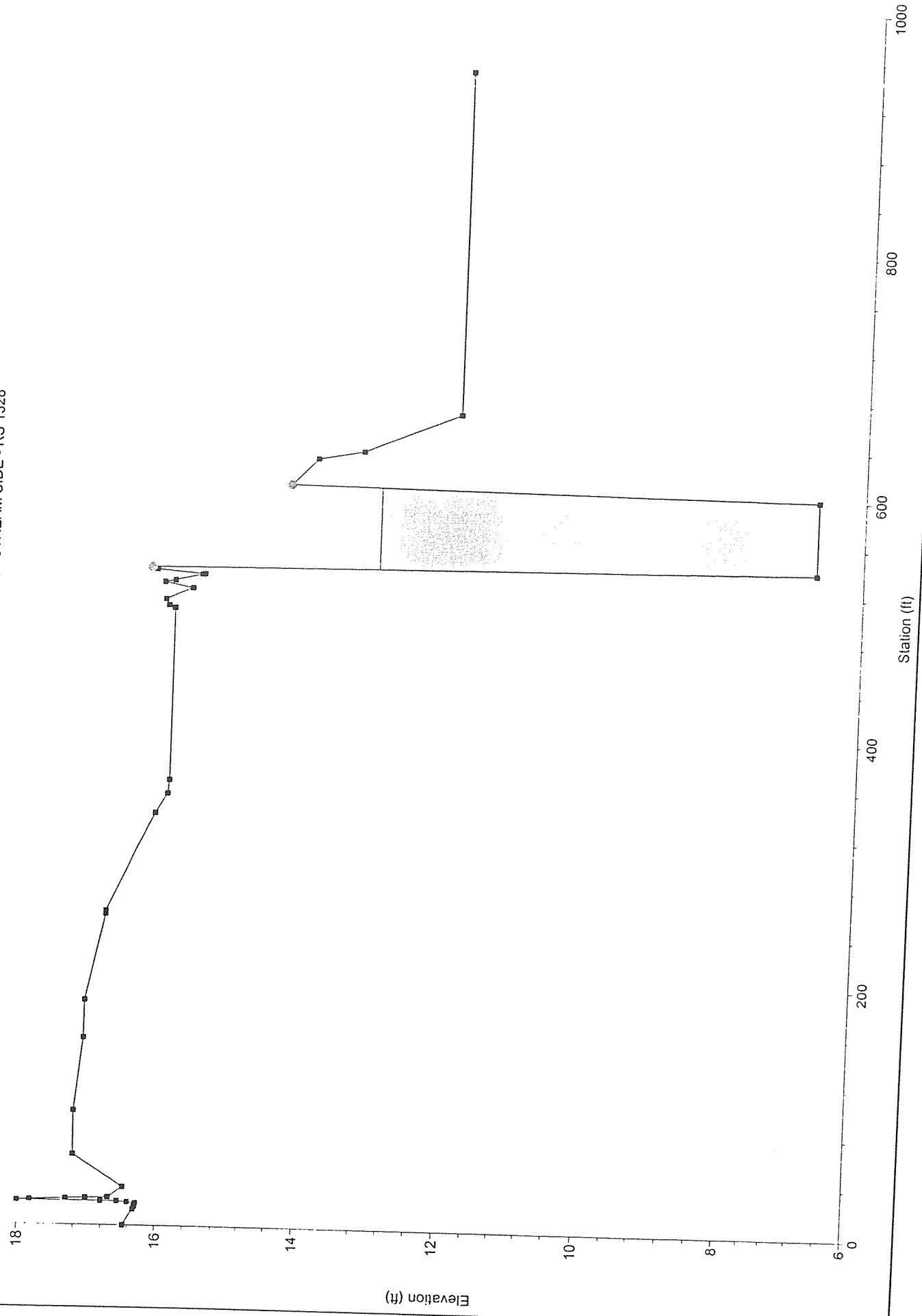

Sycamore Creek Plan: MASTER PLAN CAPACITY RUN 10/29/2003  
 RS = 1510.343 BETWEEN ZOO AND RAILROAD - RS 1510

Legend	
WS 3000	—
Ground	■
Levee	⊗
Bank Sta	⊙

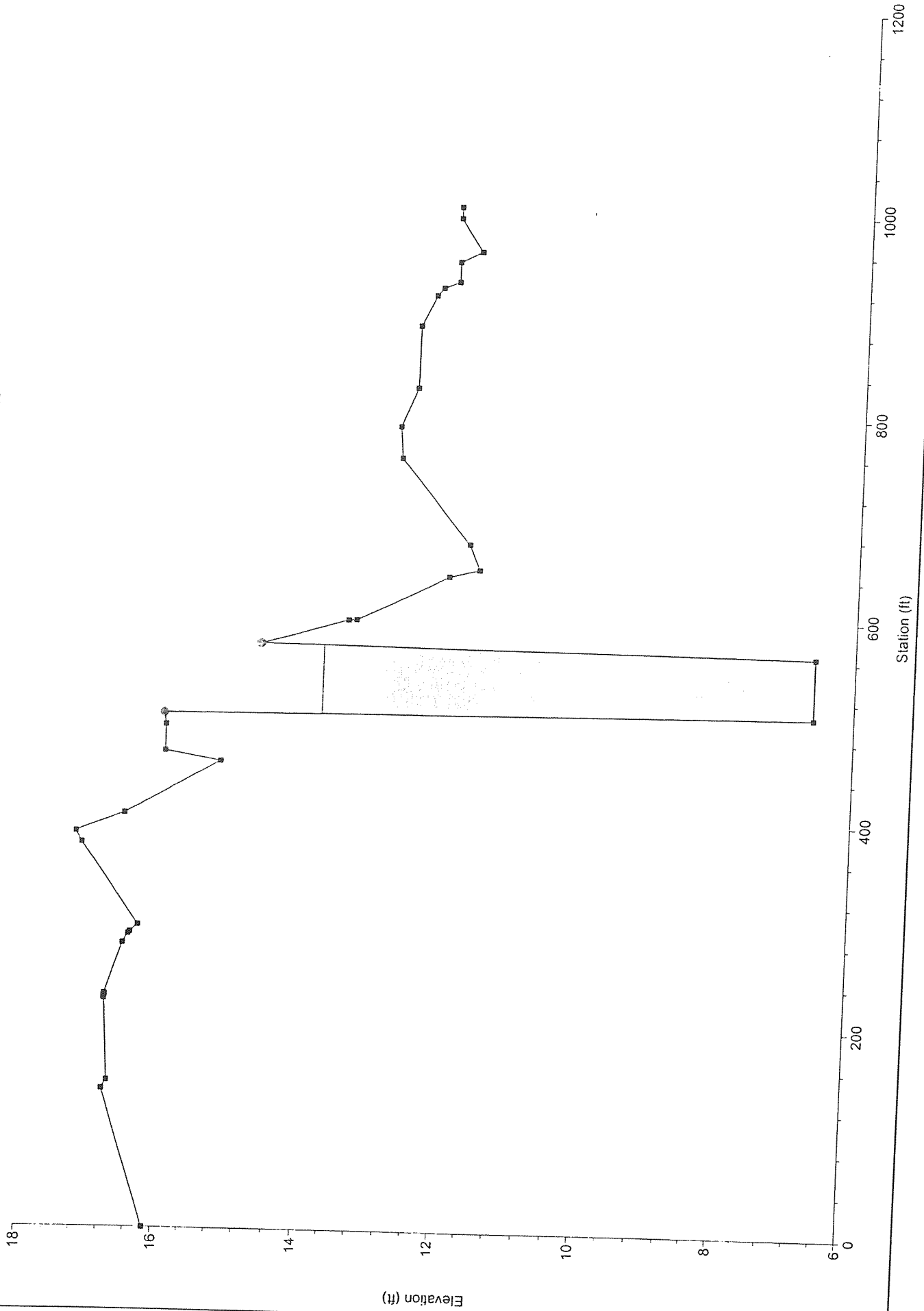

Sycamore Creek Plan: MASTER PLAN CAPACITY RUN 10/29/2003  
 RS = 1652.758 RR BRIDGE - DOWNSTREAM SIDE - RS 1652

Legend	
WS 3000	Ground
Levee	Bank Sta

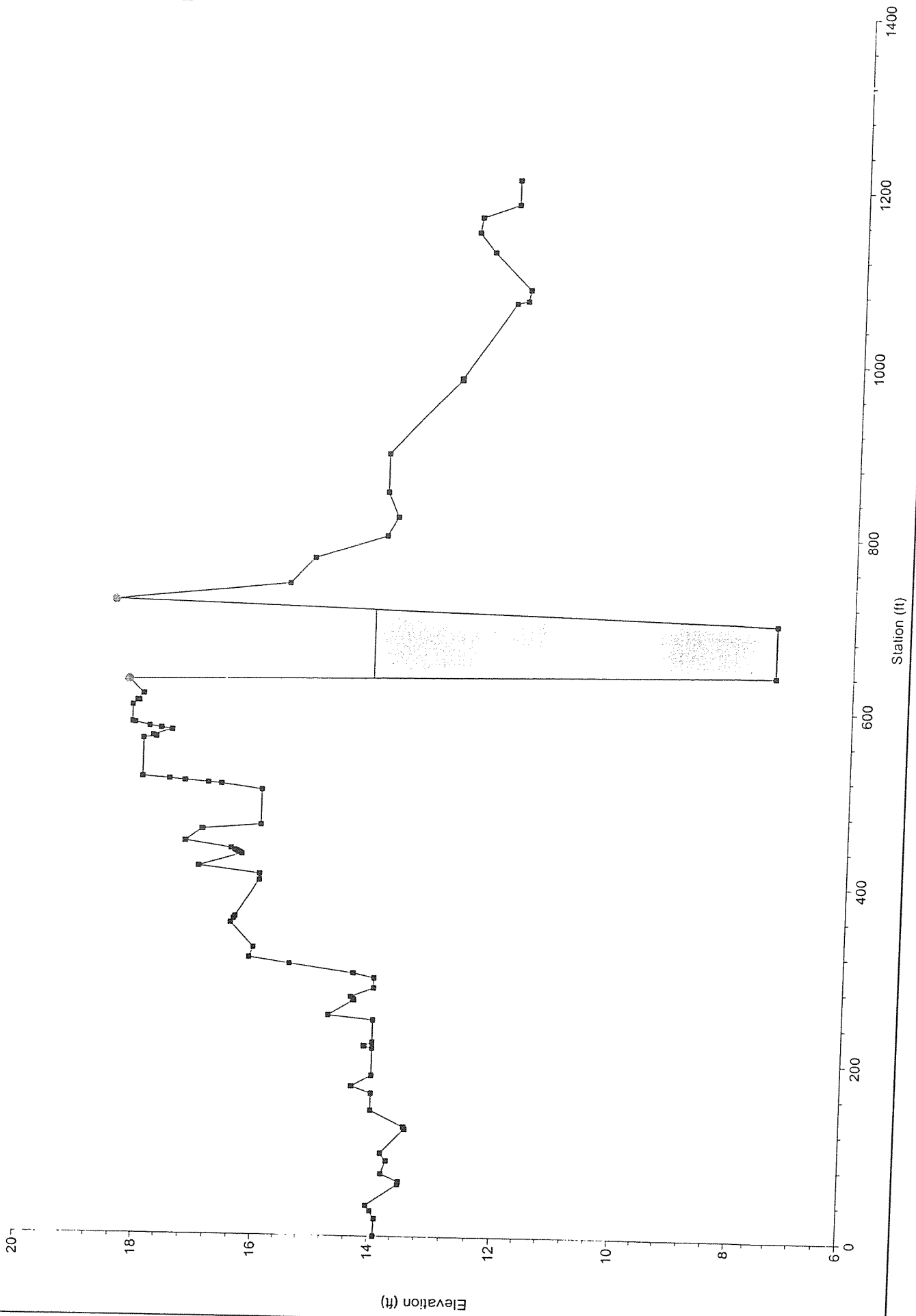

Sycamore Creek Plan: MASTER PLAN CAPACITY RUN 10/29/2003  
RS = 1655 BR RR BRIDGE (B)

Legend	
WS 3000	□
Ground	○
Levee	▨
Bank Sta	●

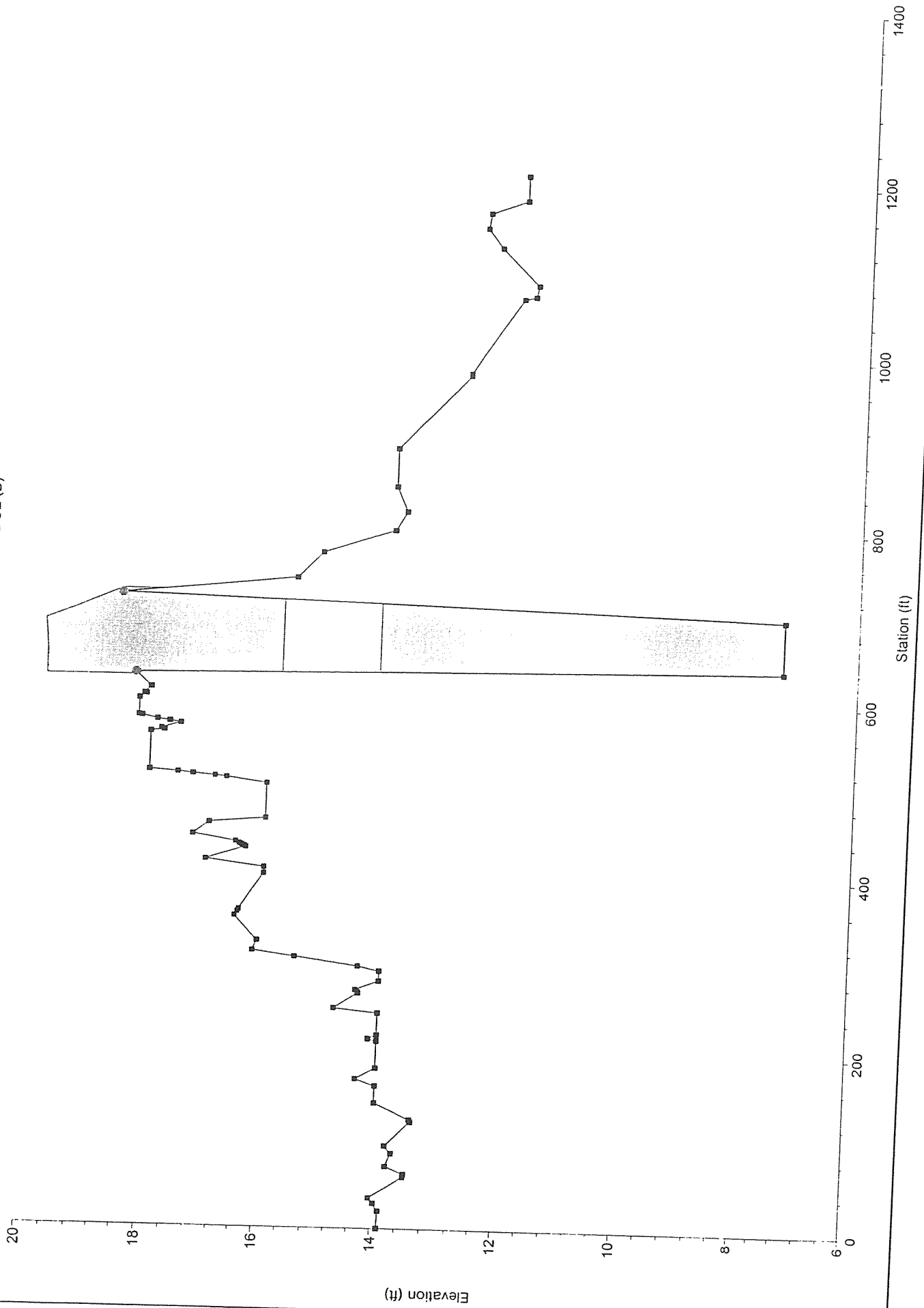

Sycamore Creek Plan: MASTER PLAN CAPACITY RUN 10/29/2003  
 RS = 1655 BR RR BRIDGE (B)

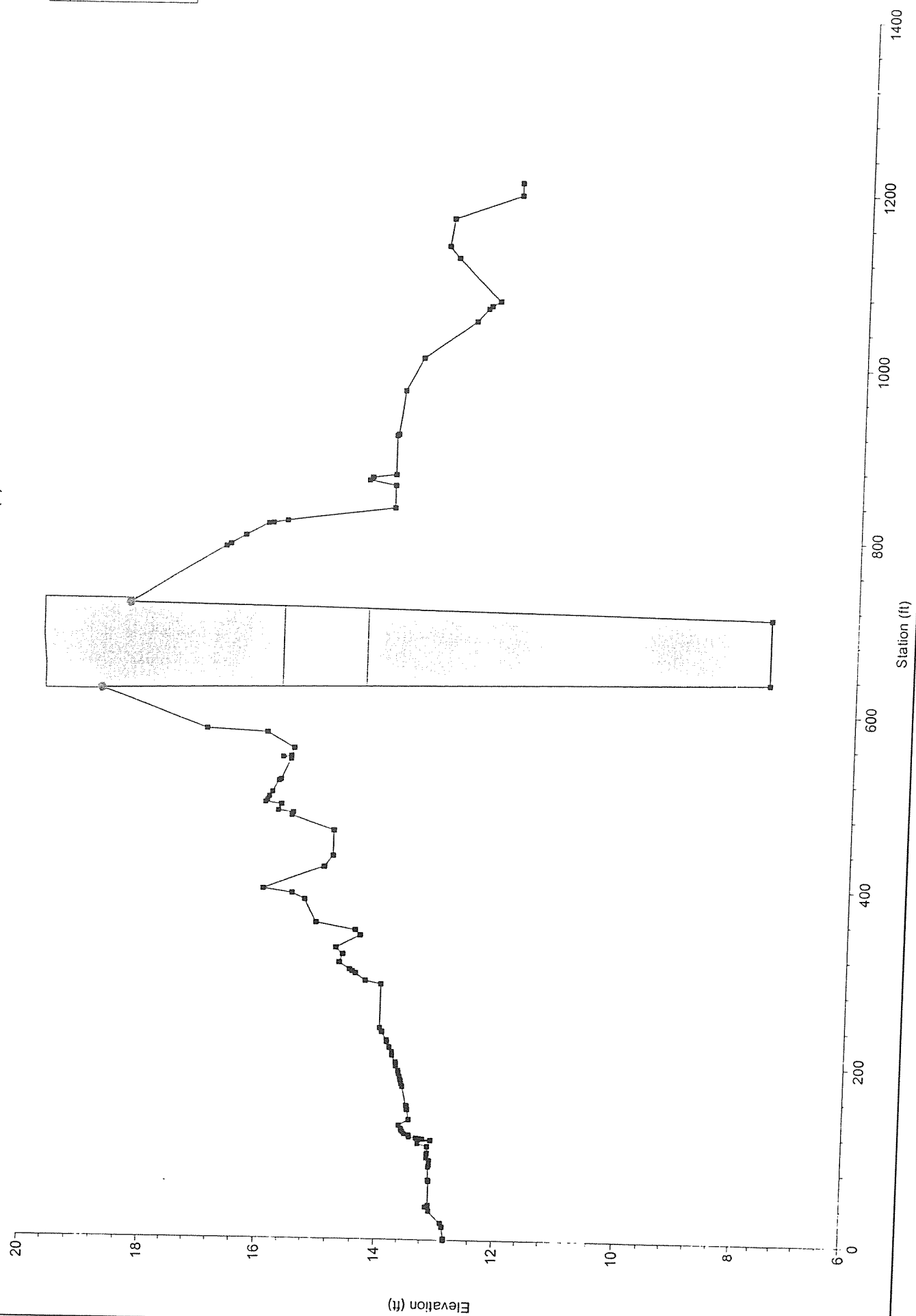

Legend	
WS 3000	—■—
Ground	—■—
Levee	■
Bank Sta	●

Sycamore Creek Plan: MASTER PLAN CAPACITY RUN 10/29/2003  
 RS = 1674.270 RR BRIDGE - UPSTREAM SIDE - RS 1674

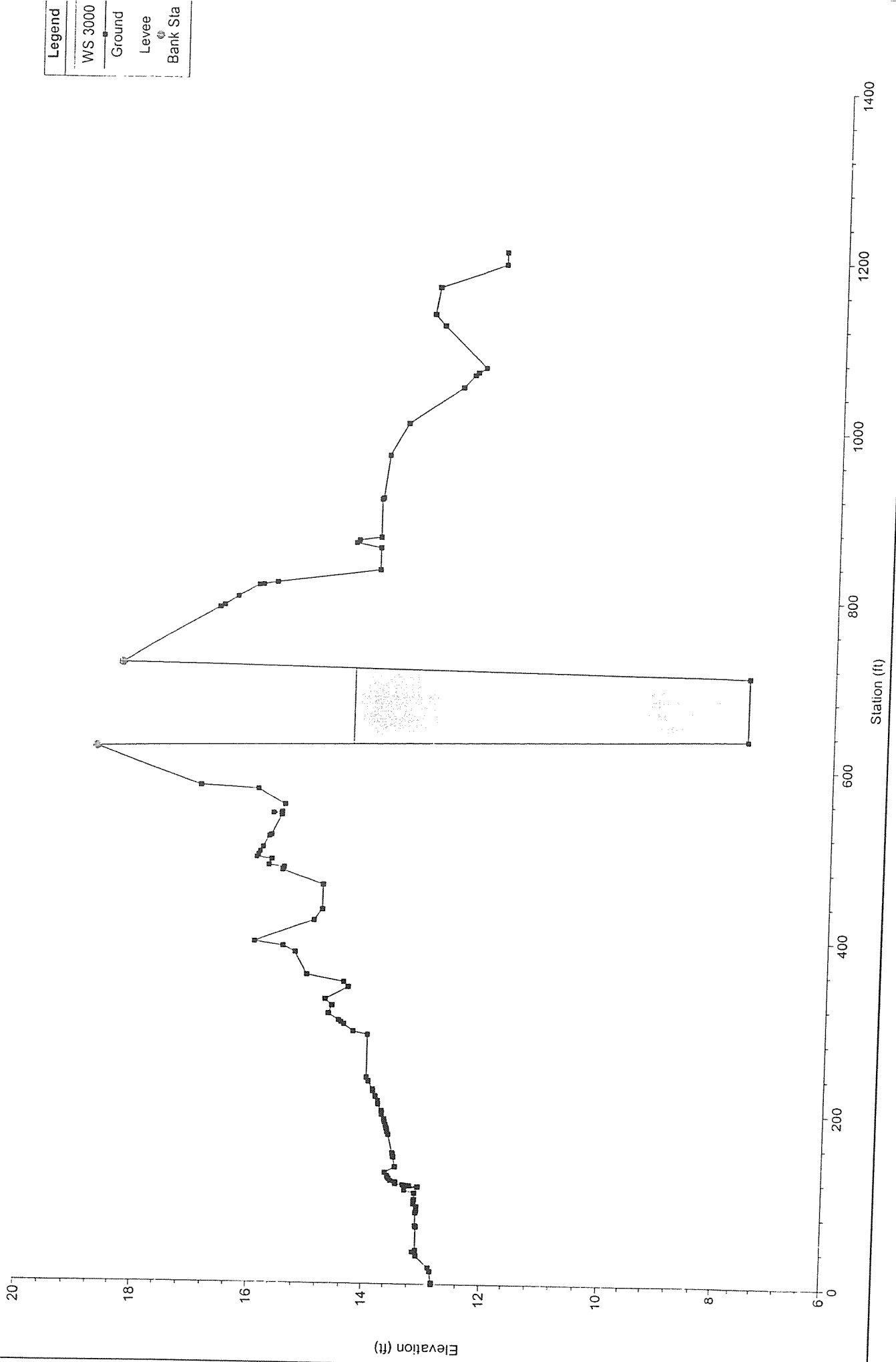

Legend	
WS 3000	—
Ground	■
Levee	○
Bank Sta	□

Sycamore Creek Plan: MASTER PLAN CAPACITY RUN 10/29/2003  
RS = 1723.388 101 BRIDGE - DOWNSTREAM SIDE - RS 1723

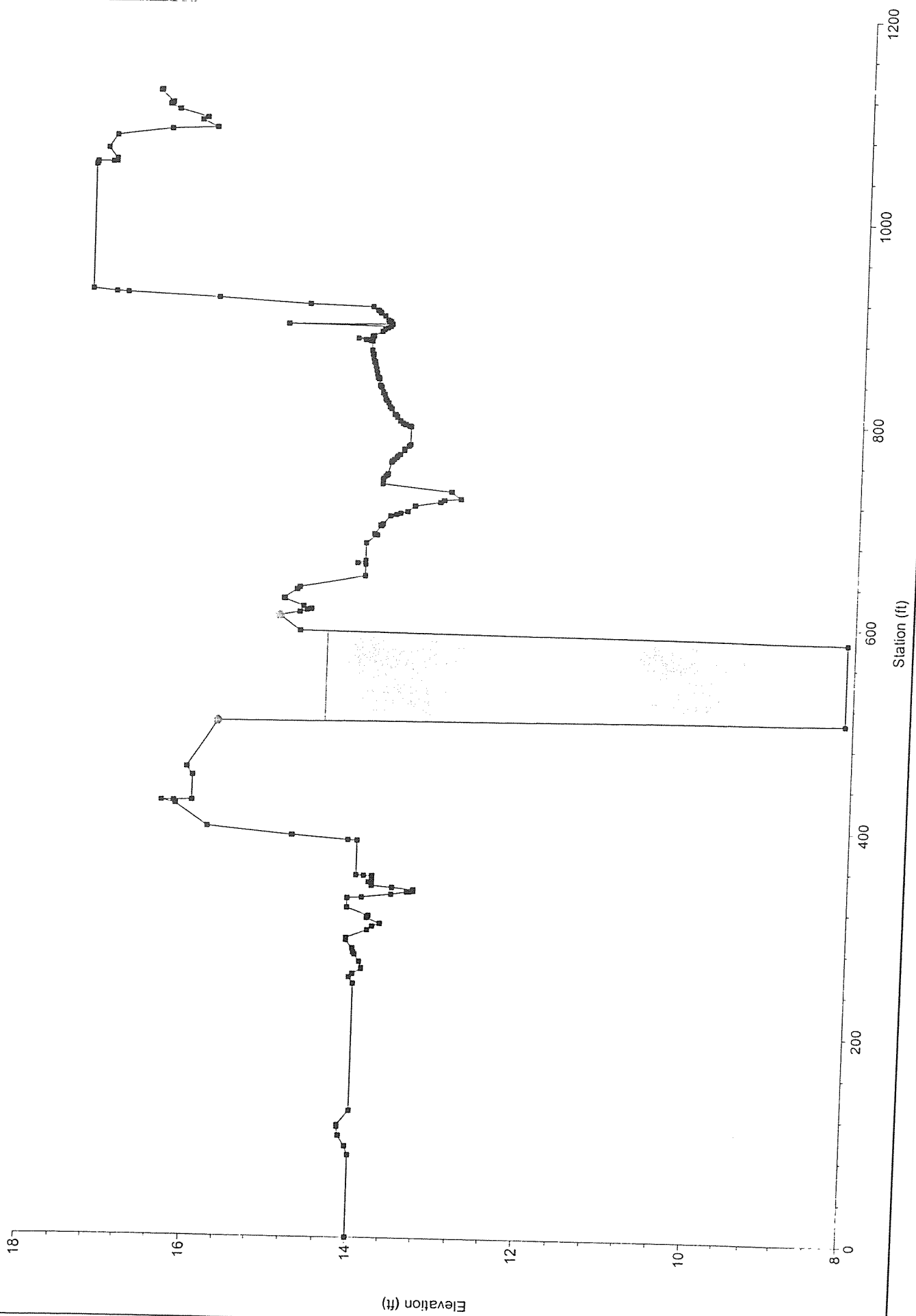

Legend	
WS 3000	Ground
Levee	Levee
Bank Sta	Bank Sta

Sycamore Creek Plan: MASTER PLAN CAPACITY RUN 10/29/2003  
RS = 1730 BR 101 BRIDGE (A)

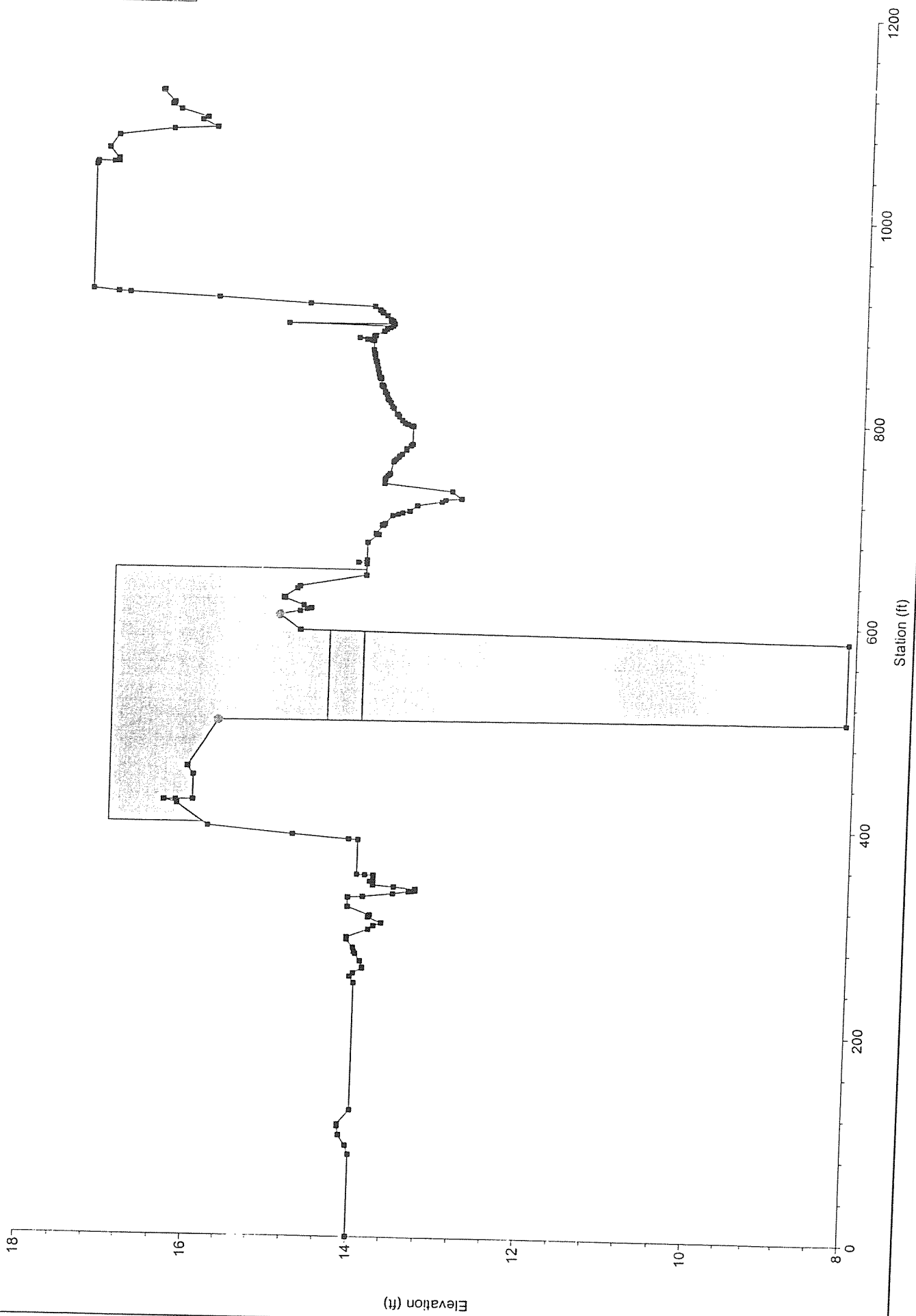

Legend	
WS 3000	Ground
Ground	Levee
Levee	Bank Sta
Bank Sta	



Sycamore Creek Plan: MASTER PLAN CAPACITY RUN 10/29/2003  
RS = 1730 BR 101 BRIDGE (A)

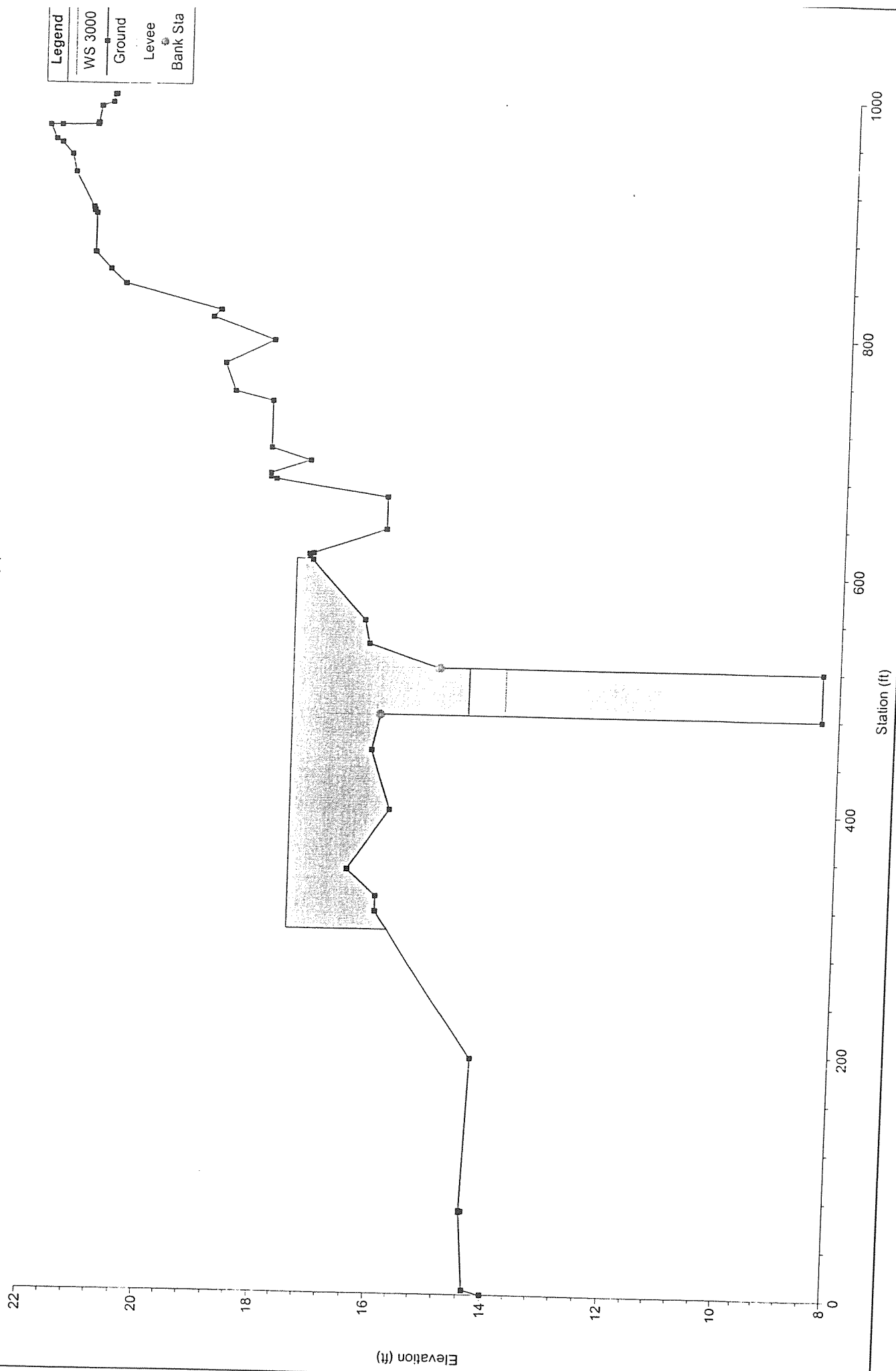

Sycamore Creek Plan: MASTER PLAN CAPACITY RUN 10/29/2003  
RS = 1831.350 101 BRIDGE - UPSTREAM SIDE - RS 1831

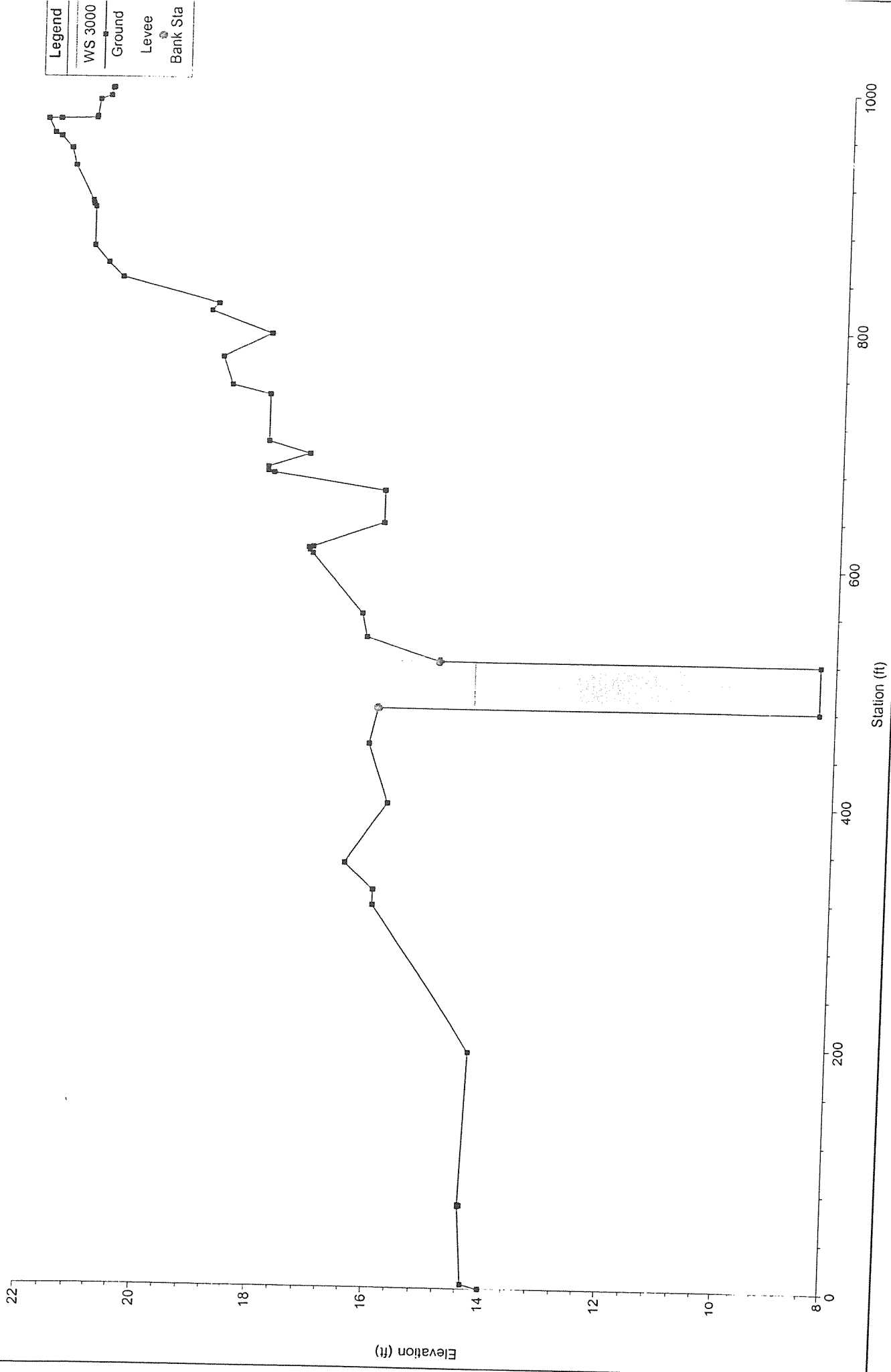

Sycamore Creek Plan: MASTER PLAN CAPACITY RUN 10/29/2003  
 RS = 2051.565 BETWEEN 101 AND PUNTA GORDA - RS 2051

Legend	
WS 3000	—
Ground	—
Levee	⊗
Bank Sta	⊙

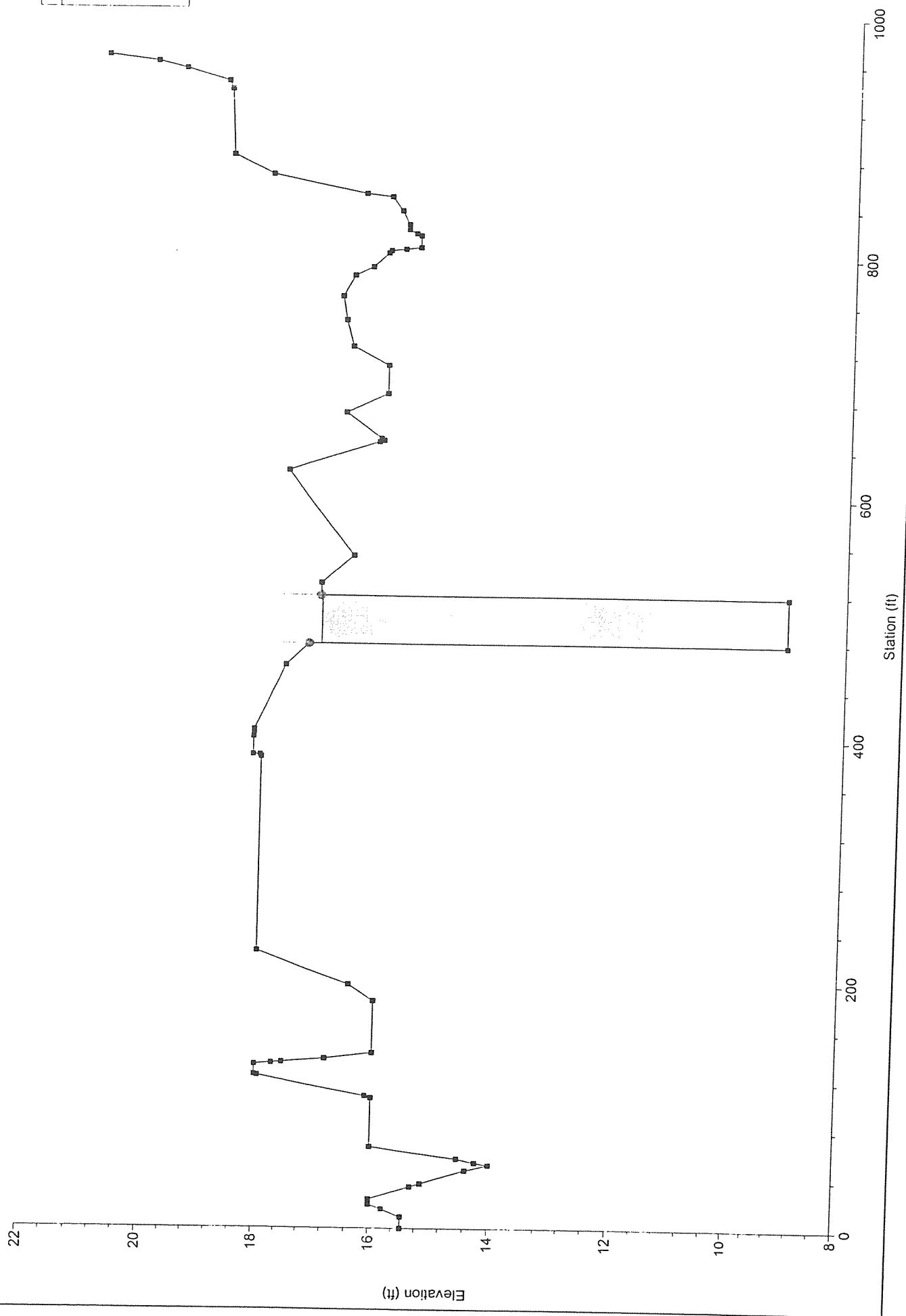

Sycamore Creek Plan: MASTER PLAN CAPACITY RUN 10/29/2003  
 RS = 2144.783 PUNTA GORDA BRIDGE - DOWNSTREAM SIDE - RS 2144

Legend	
WS 3000	Ground
Levee	Bank Sta

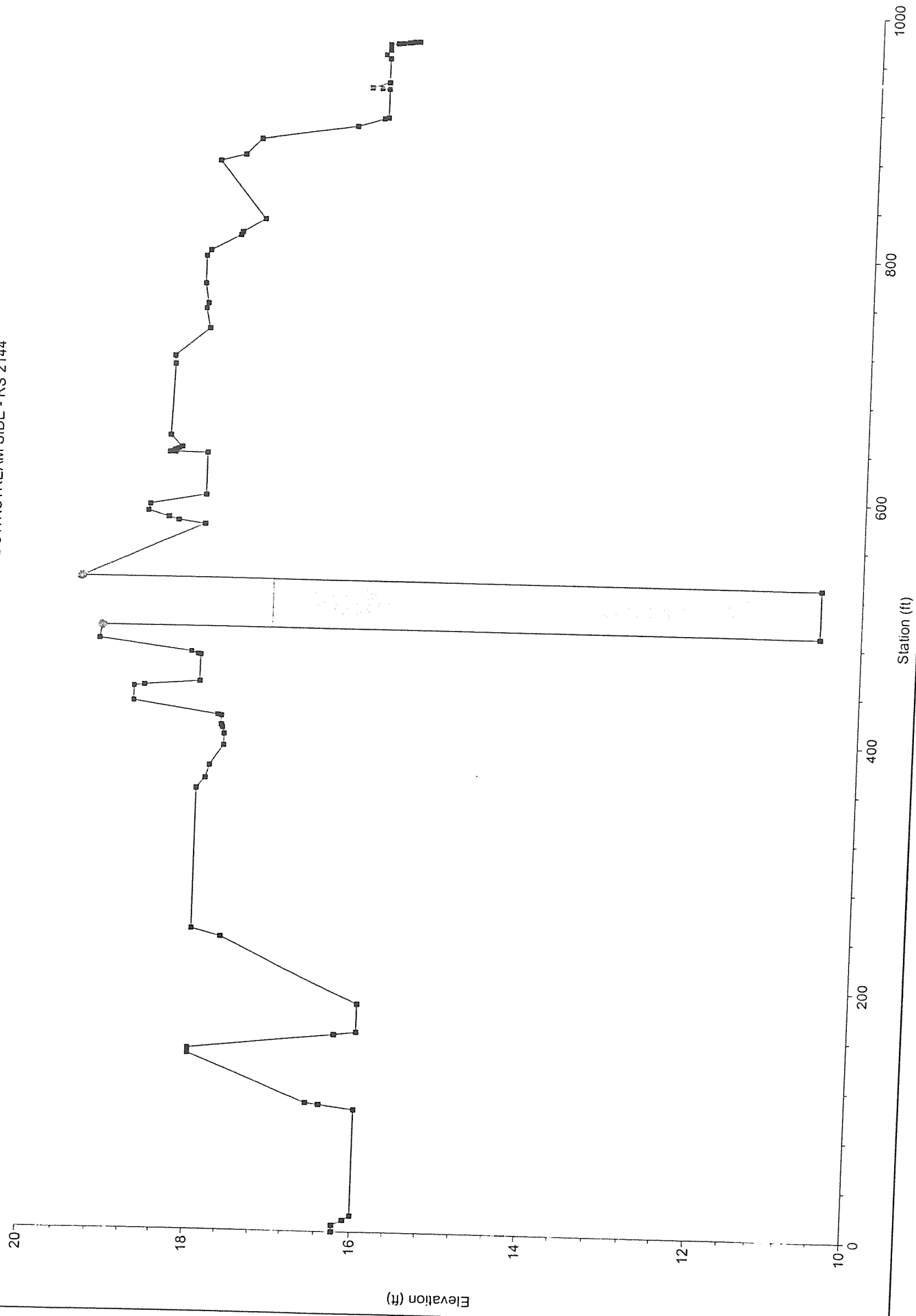

Sycamore Creek Plan: MASTER PLAN CAPACITY RUN 10/29/2003  
RS = 2151 BR PUNTA GORDA BRIDGE (J)

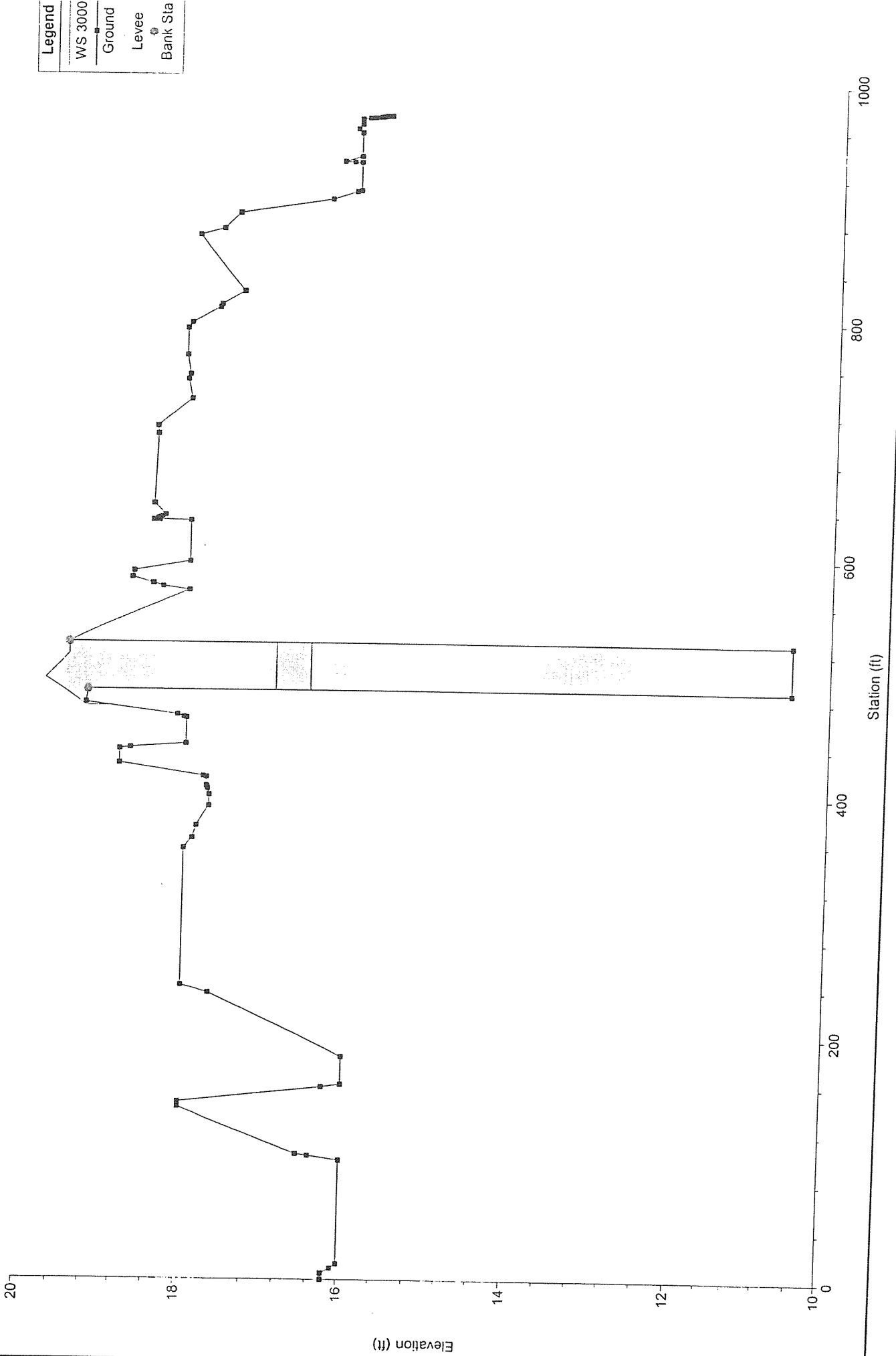

Sycamore Creek Plan: MASTER PLAN CAPACITY RUN 10/29/2003  
 RS = 2151 BR PUNTA GORDA BRIDGE (J)

Legend	
WS 3000	Ground
Levee	Bank Sta

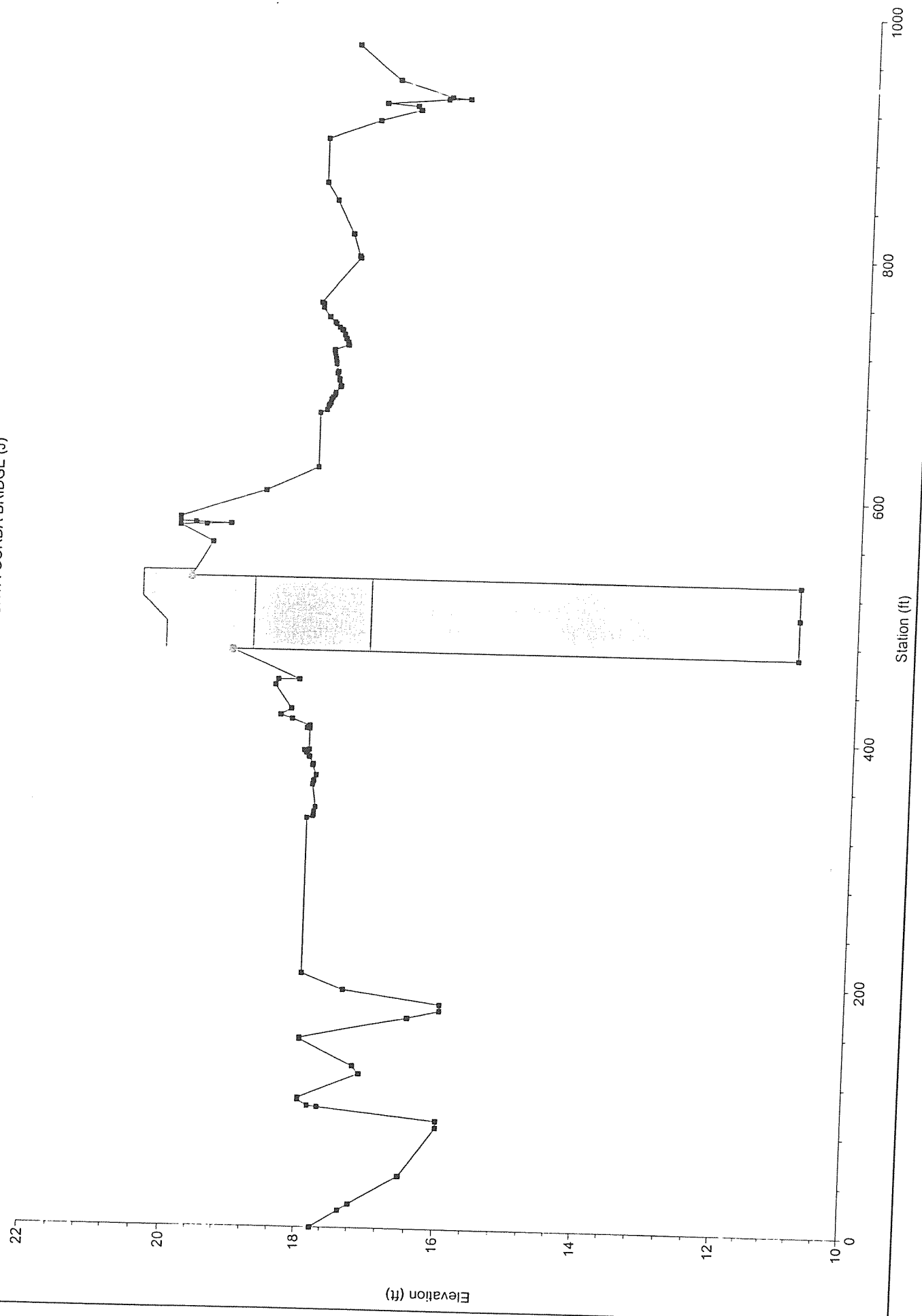

Sycamore Creek Plan: MASTER PLAN CAPACITY RUN 10/29/2003  
 RS = 2181.047 PUNTA GORDA BRIDGE - UPSTREAM SIDE - RS 2181

Legend	
WS 3000	Ground
	Levee
	Bank Sta

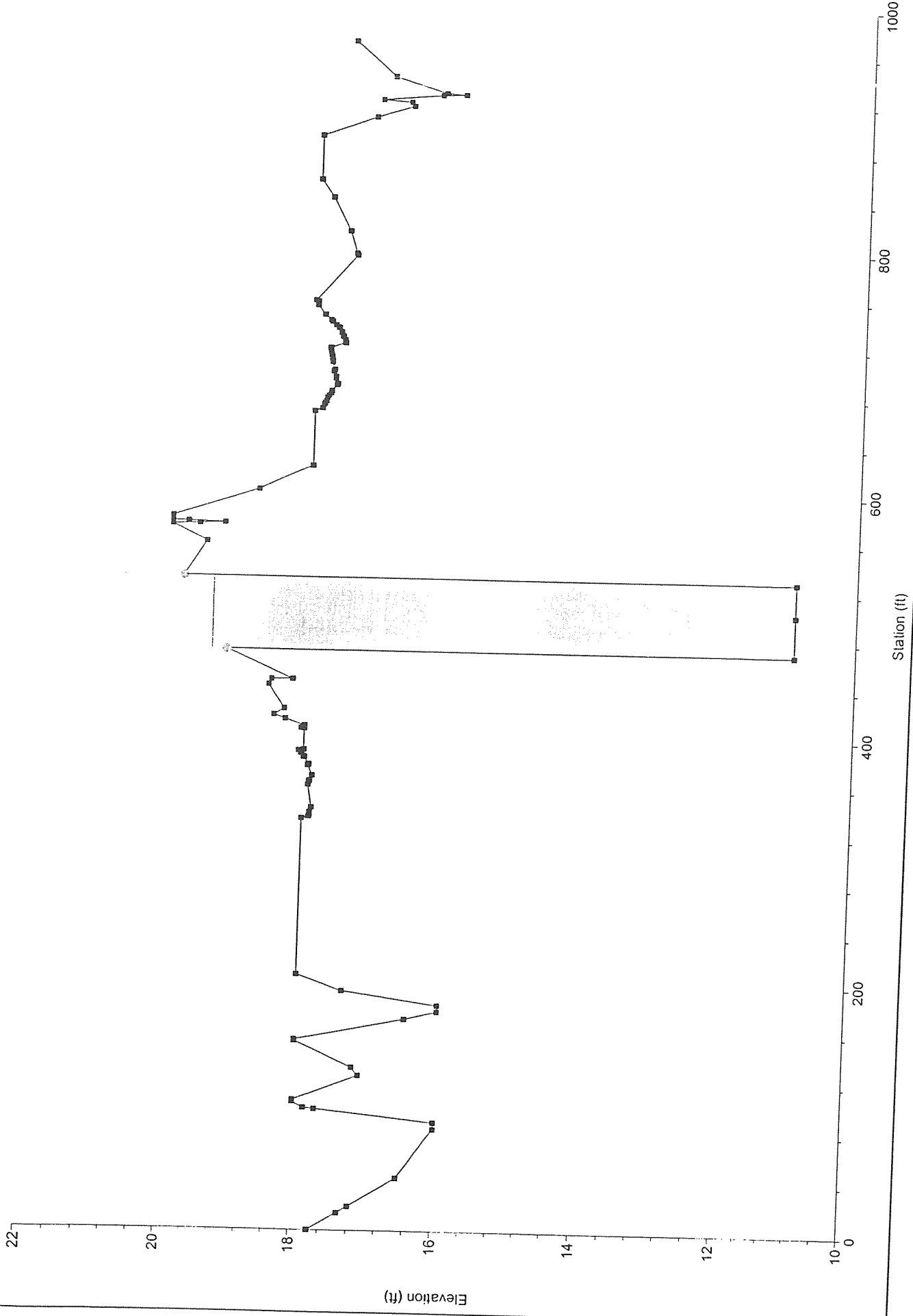

Sycamore Creek Plan: MASTER PLAN CAPACITY RUN 10/29/2003  
 RS = 2294.216 BETWEEN PUNTA GORDA AND INDIO MUERTO #1 - RS 2294

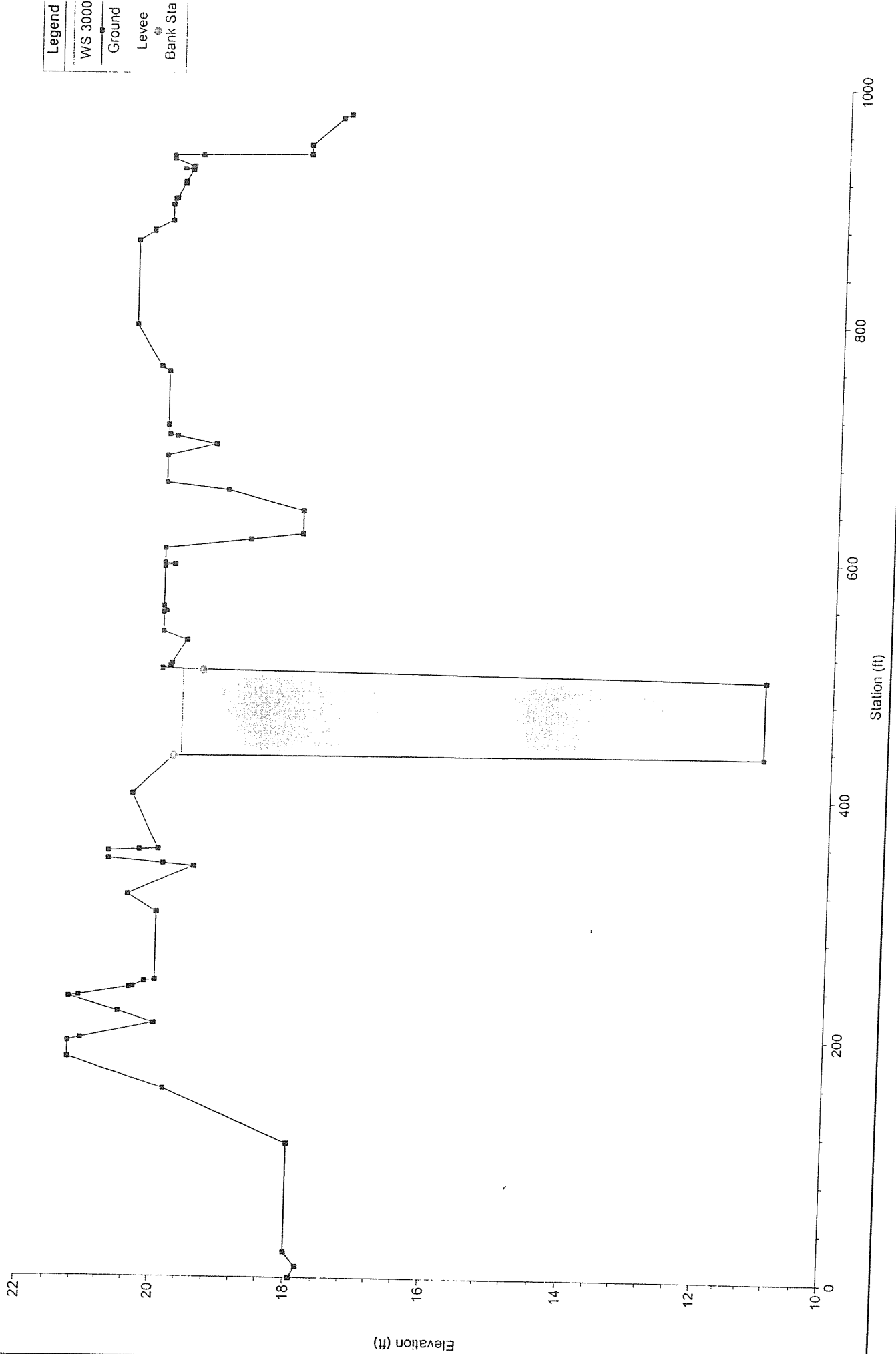

Legend  
 WS 3000  
 Ground  
 Levee  
 Bank Sta



Sycamore Creek Plan: MASTER PLAN CAPACITY RUN 10/29/2003  
RS = 2529.295 BETWEEN PUNTA GORDA AND INDIO MUERTO #2 - RS 2529

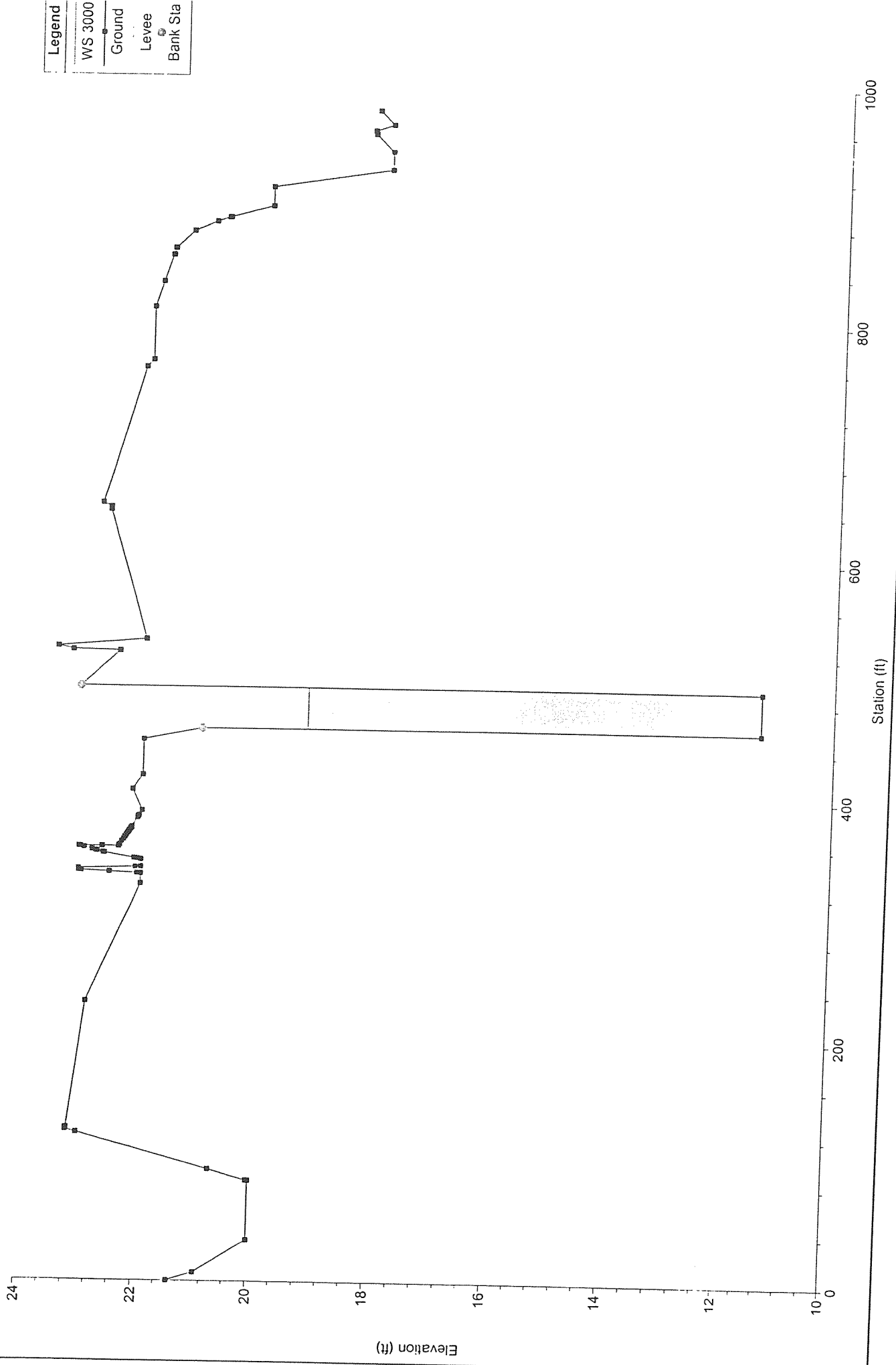

Sycamore Creek Plan: MASTER PLAN CAPACITY RUN 10/29/2003  
 RS = 2729.978 INDIO MUERTO BRIDGE - DOWNSTREAM SIDE - RS 2729

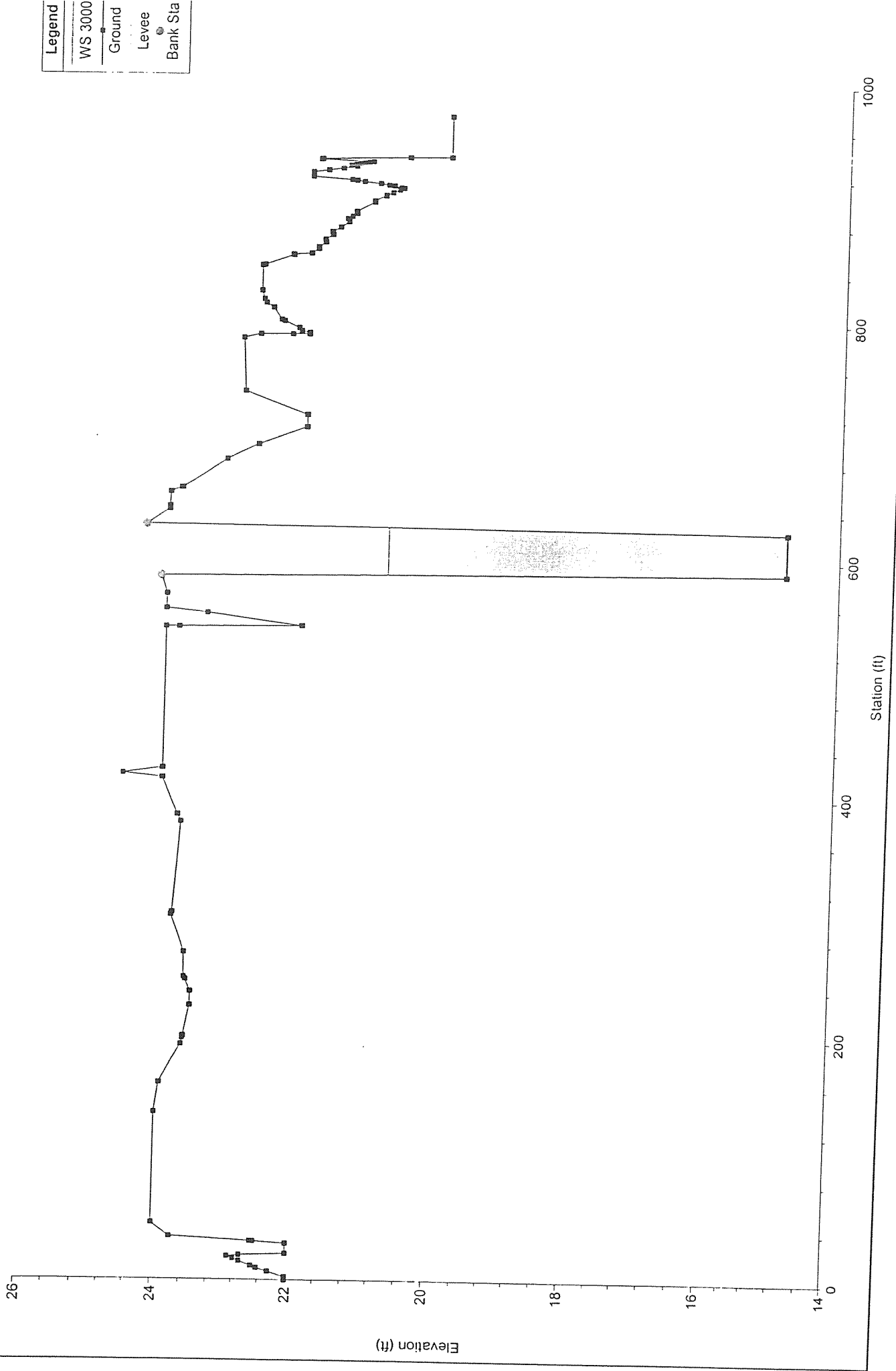

Legend	
WS 3000	—
Ground	—■—
Levee	▨
Bank Sta	○

Sycamore Creek Plan: MASTER PLAN CAPACITY RUN 10/29/2003  
RS = 2732 BR INDIO MUERTO BRIDGE (I)

Legend	
WS 3000	—
Ground	—
Levee	—
Bank Sta	⊕

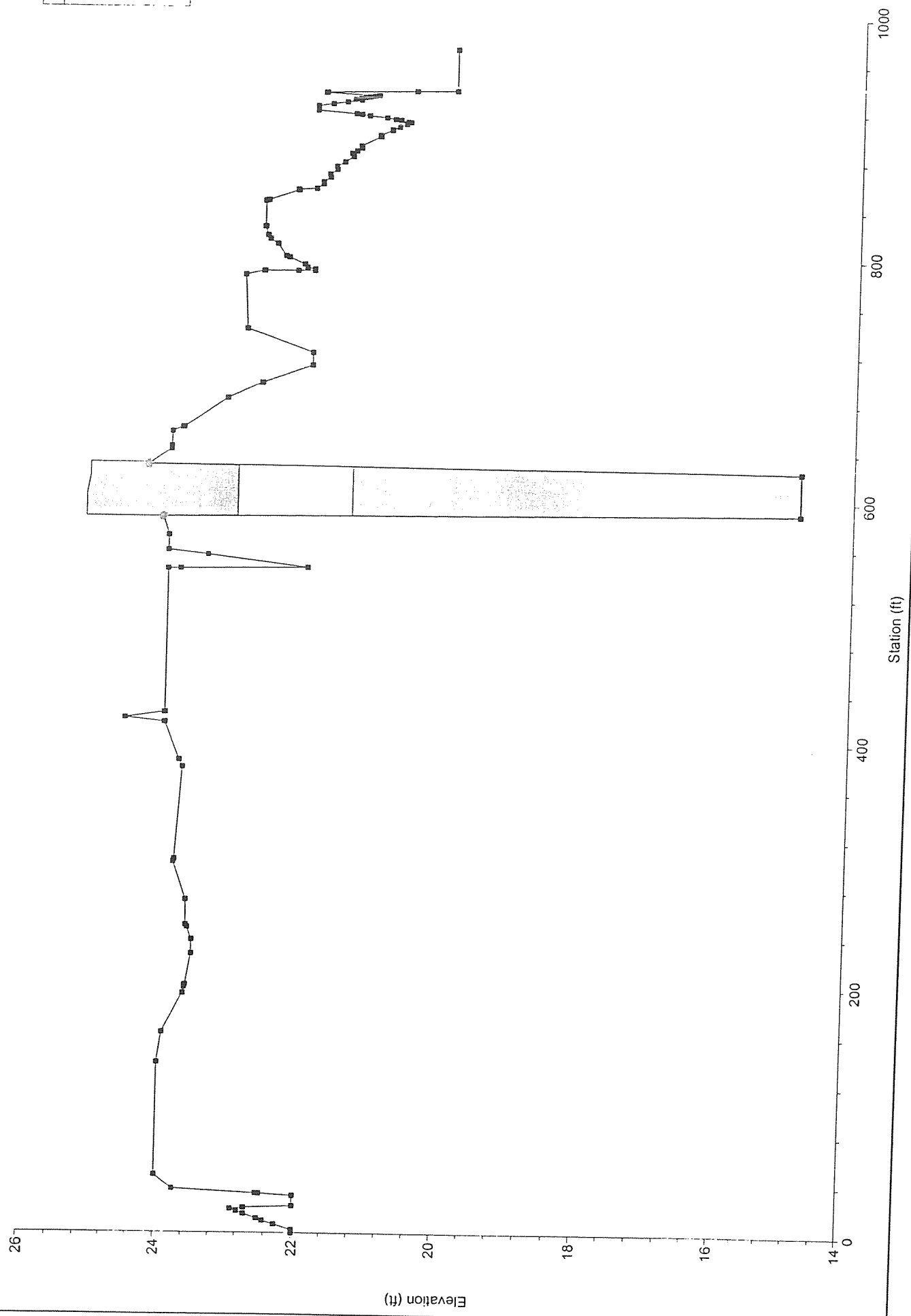

Sycamore Creek Plan: MASTER PLAN CAPACITY RUN 10/29/2003  
 RS = 2732 BR INDIO MUERTO BRIDGE (I)

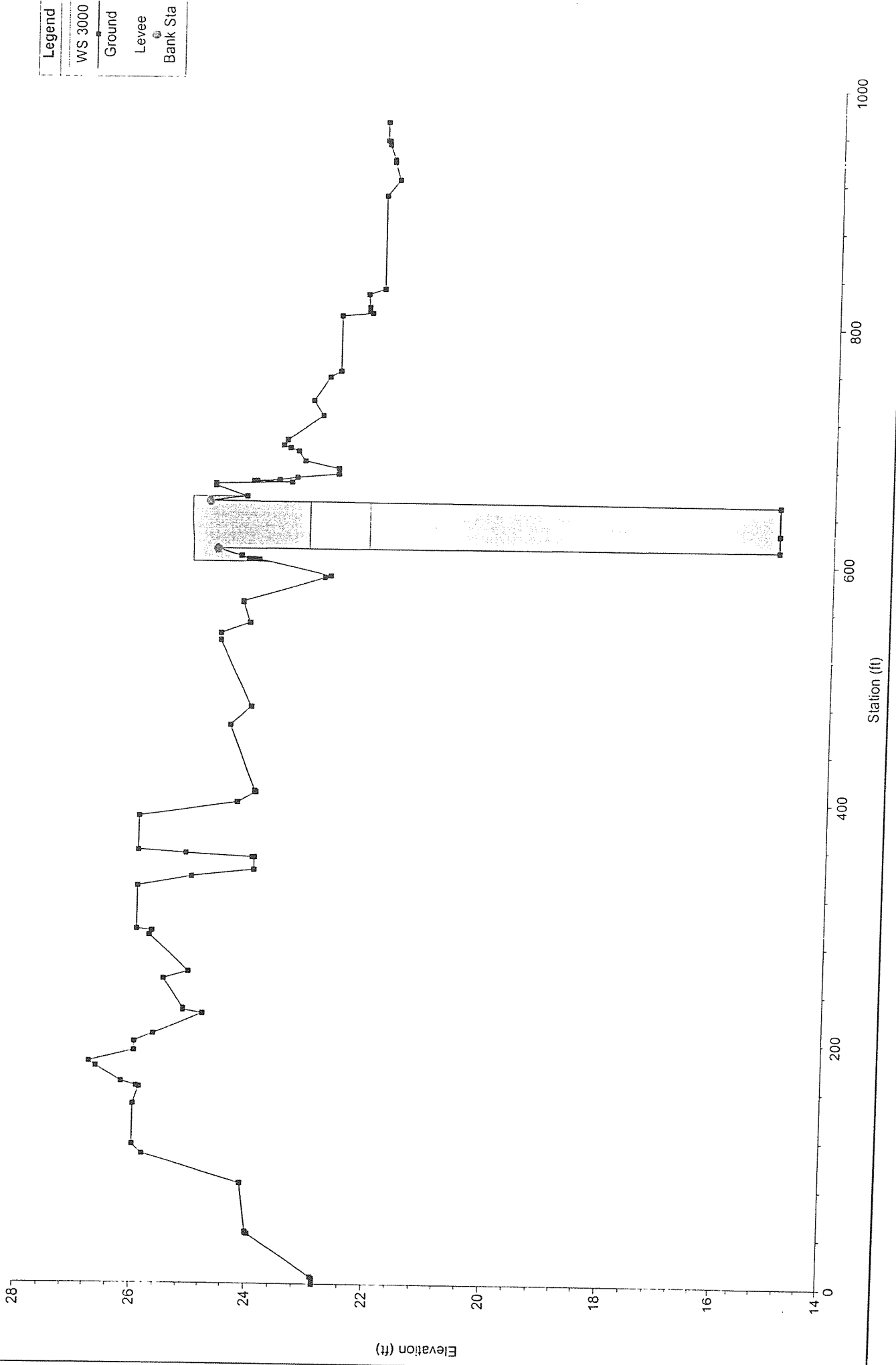

Sycamore Creek Plan: MASTER PLAN CAPACITY RUN 10/29/2003  
 RS = 2773.736 INDIO MUERTO BRIDGE- UPSTREAM SIDE - RS 2773

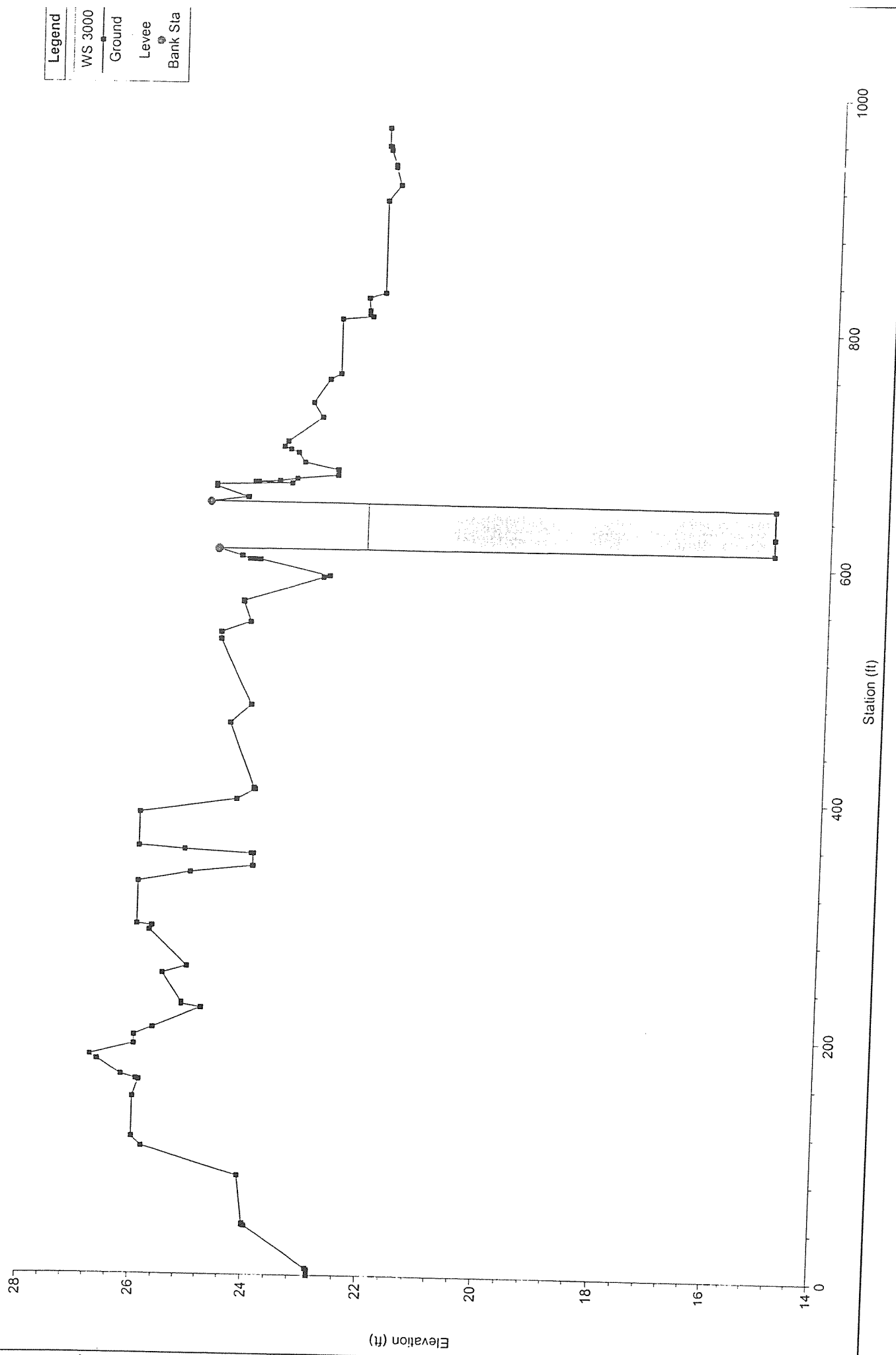

Sycamore Creek Plan: MASTER PLAN CAPACITY RUN 10/29/2003  
 RS = 2805.371 BETWEEN INDIO MUERTO AND CACIQUE #1 - RS 2805

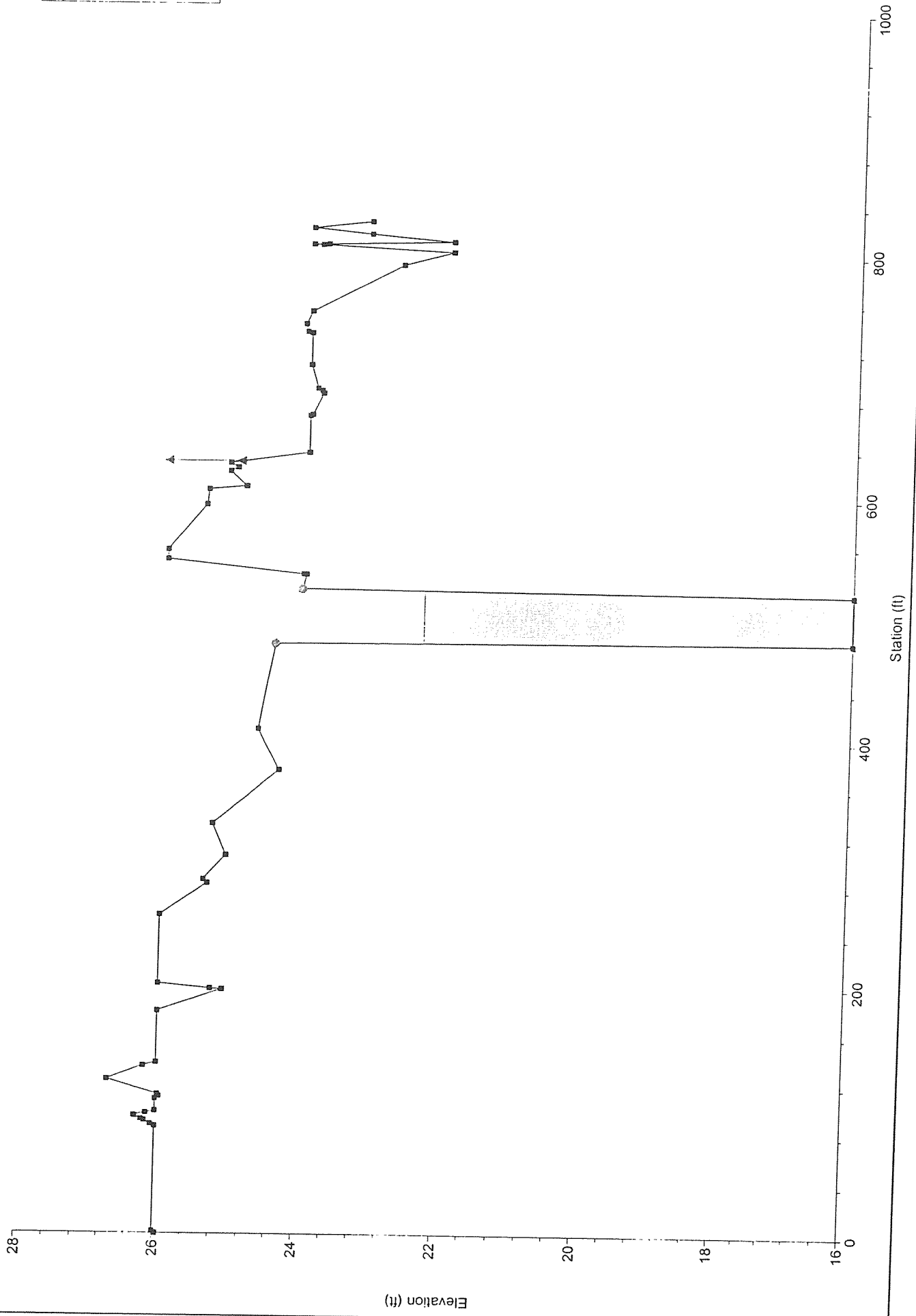

Legend	
WS 3000	Ground
Levee	Ineff
Bank Sta	

Sycamore Creek Plan: MASTER PLAN CAPACITY RUN 10/29/2003  
 RS = 3198.905 BETWEEN INDIJO MUERTO AND CACIQUE #2 - RS 3198

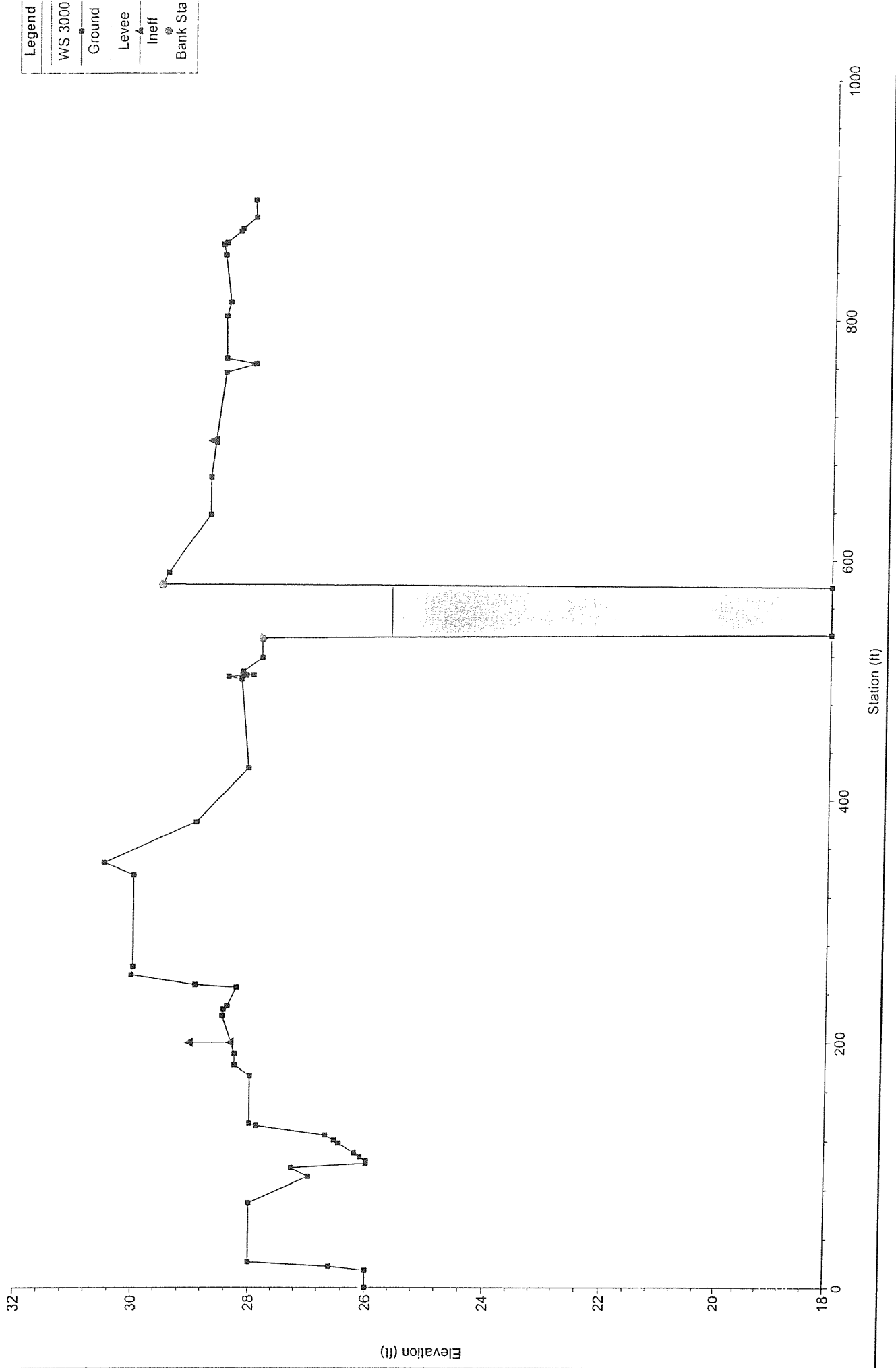

Sycamore Creek Plan: MASTER PLAN CAPACITY RUN 10/29/2003  
 RS = 3277.052 CACIQUE BRIDGE - DOWNSTREAM SIDE - RS 3277

Legend	
WS 3000	Ground
	Levee
	Bank Sta

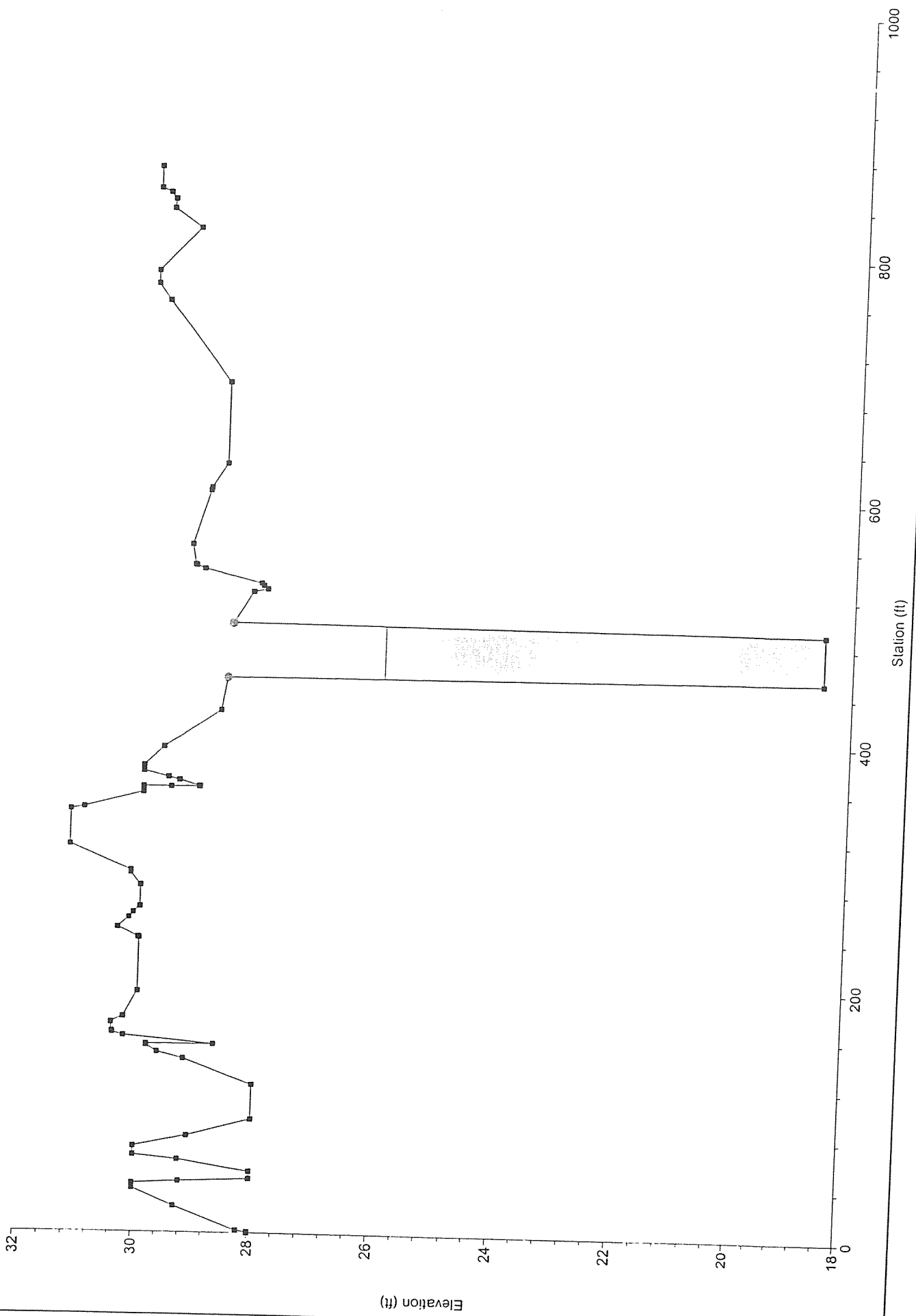



Sycamore Creek Plan: MASTER PLAN CAPACITY RUN 10/29/2003  
RS = 3278 BR CACIQUE BRIDGE (H)

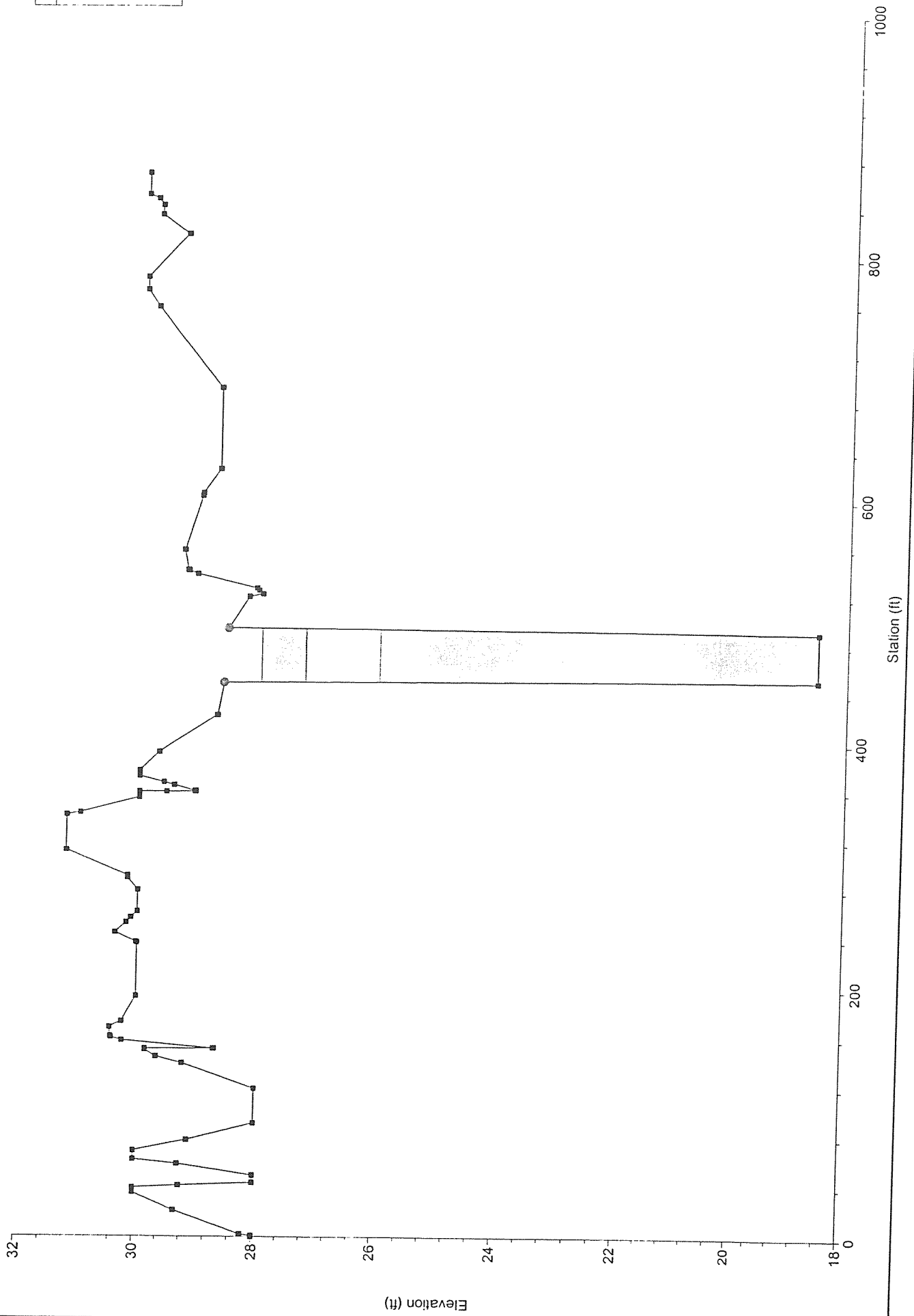

Legend  
WS 3000  
Ground  
Levee  
Bank Sta

Sycamore Creek Plan: MASTER PLAN CAPACITY RUN 10/29/2003  
RS = 3278 BR CACIQUE BRIDGE (H)

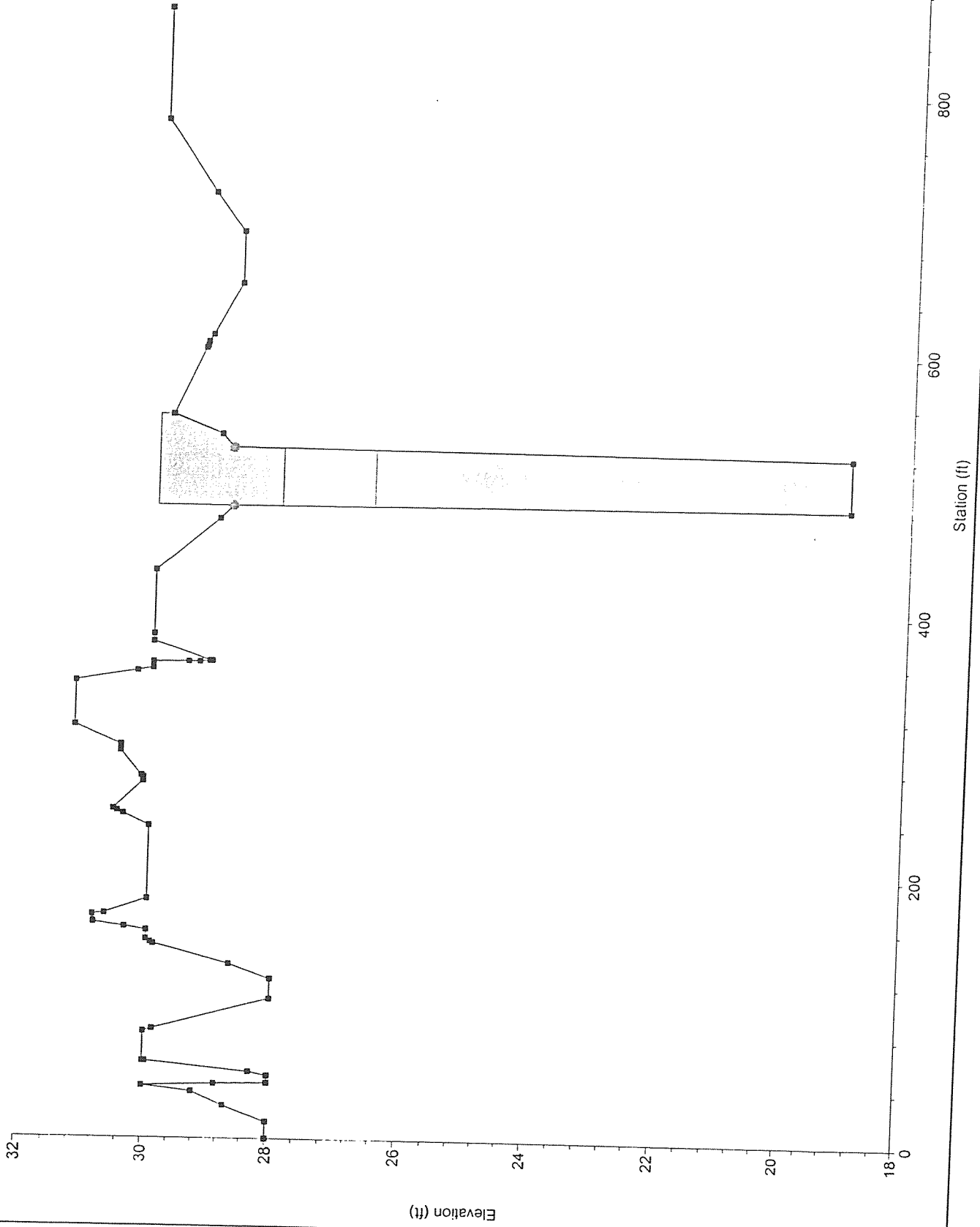

Sycamore Creek Plan: MASTER PLAN CAPACITY RUN 10/29/2003  
 RS = 3287.068 CACIQUE BRIDGE - UPSTREAM SIDE - RS 3287

Legend	
WS 3000	Ground
Levee	Bank Sta

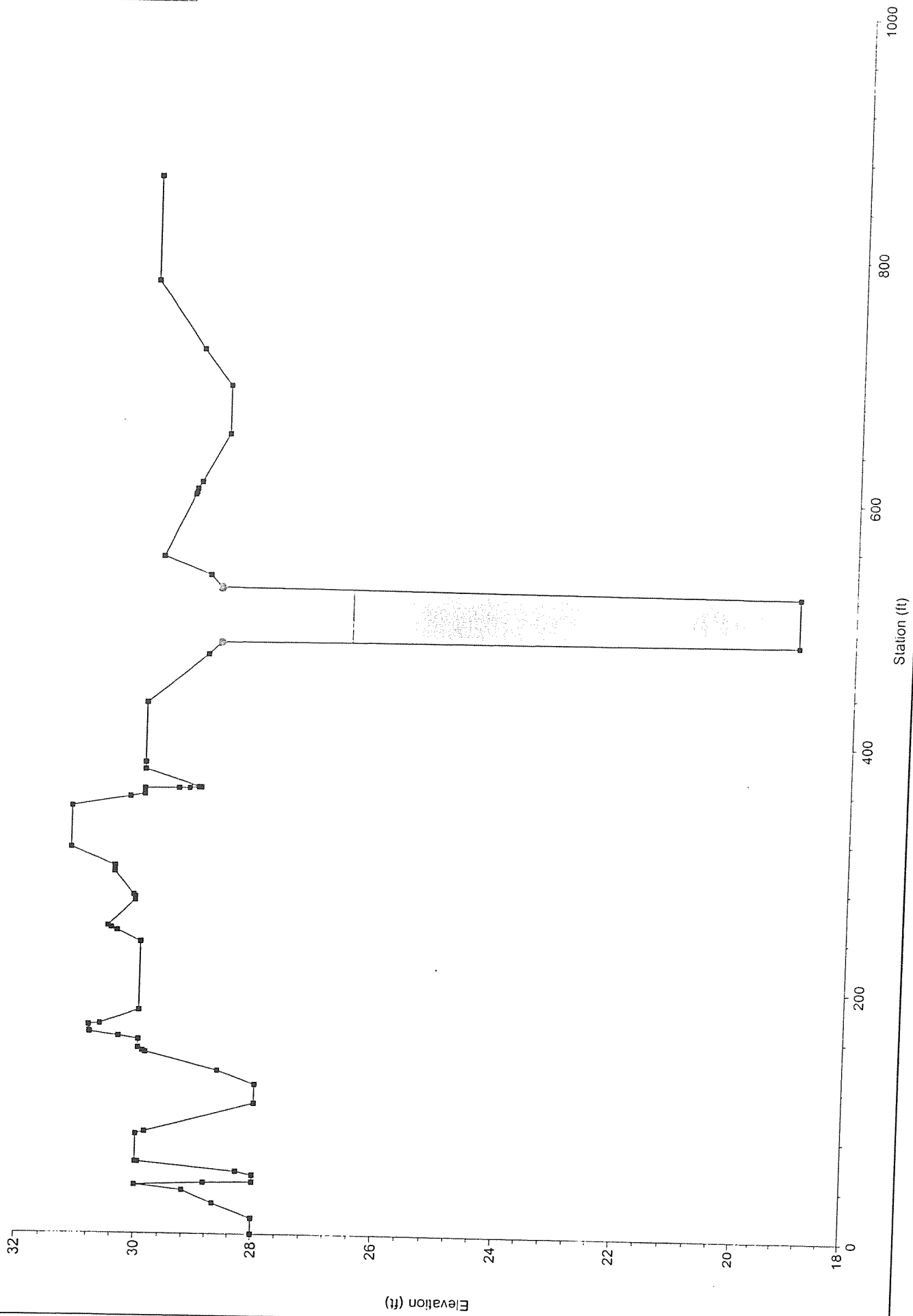

Sycamore Creek Plan: MASTER PLAN CAPACITY RUN 10/29/2003  
 RS = 3792.019 BETWEEN CACIQUE AND CARPINTERIA #1 - RS 3792

Legend	
WS 300f	—
Ground	—
Levee	▨
Bank Sta	⊙

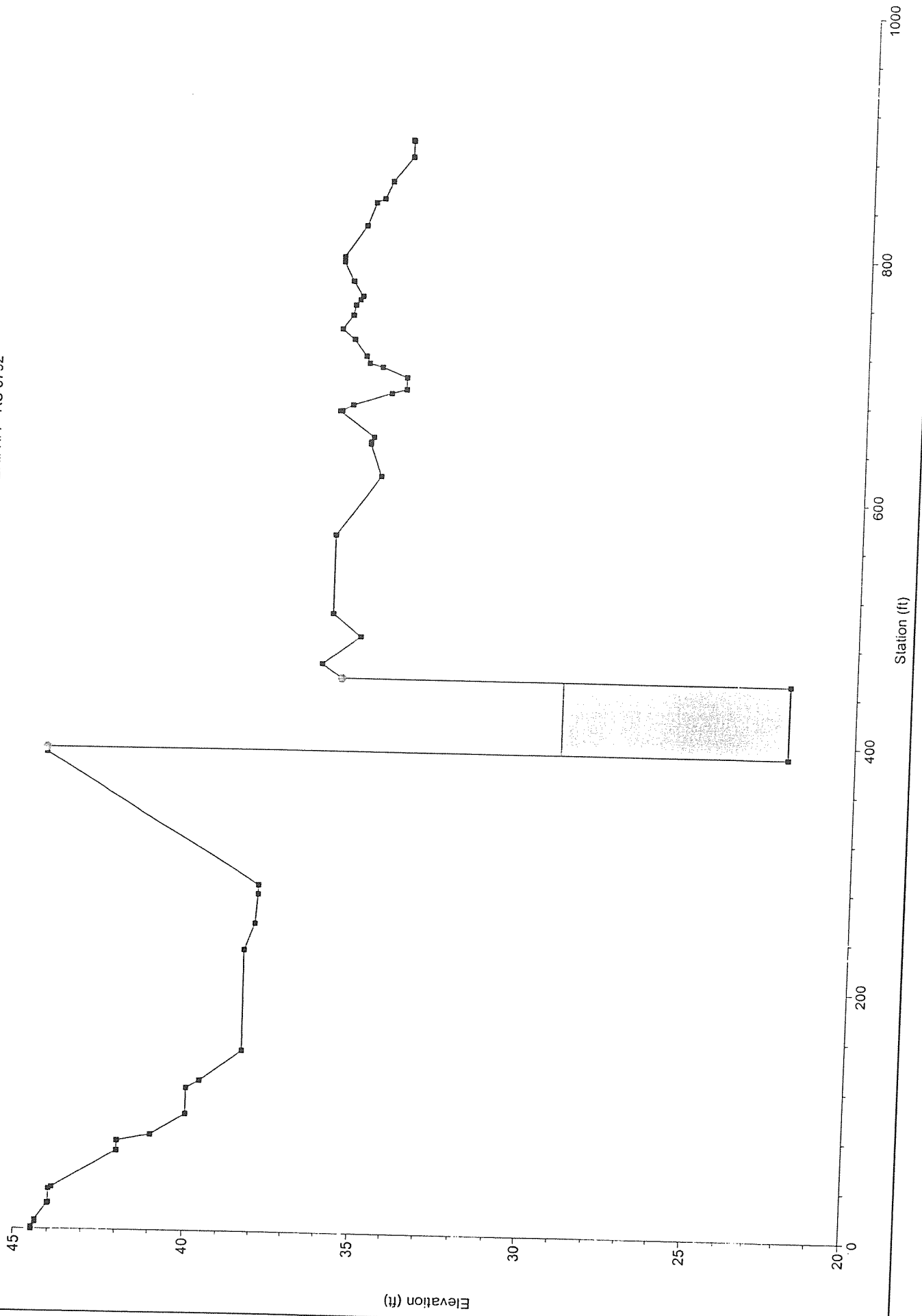

Sycamore Creek Plan: MASTER PLAN CAPACITY RUN 10/29/2003  
RS = 3837.489 BETWEEN CACIQUE AND CARPINTERIA #2 - RS 3837

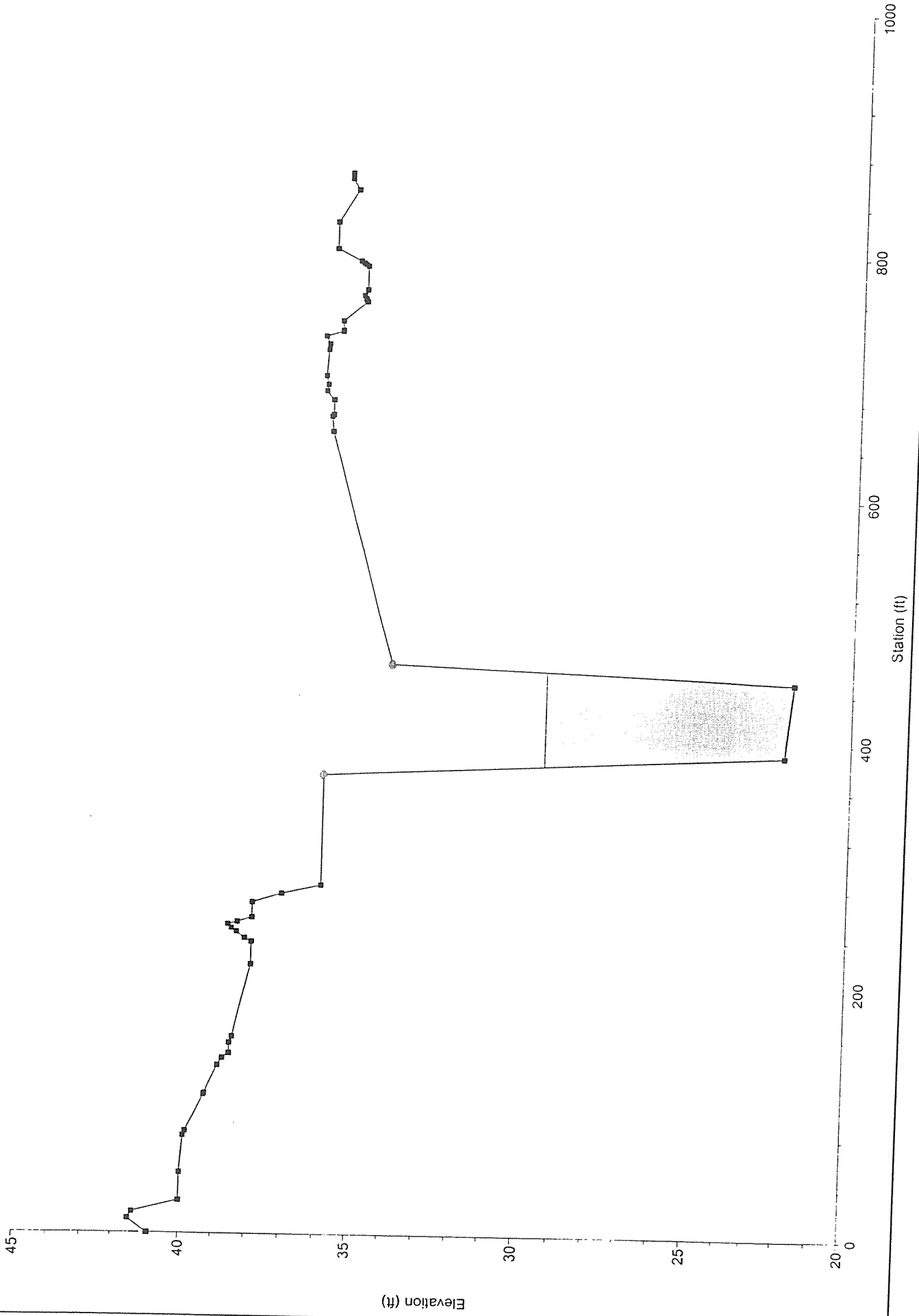

Legend	
WS 3000	Ground
Levee	Levee
Bank Sta	Bank Sta

Sycamore Creek Plan: MASTER PLAN CAPACITY RUN 10/29/2003  
 RS = 3914.370 CARPINTERIA BRIDGE - DOWNSTREAM SIDE - RS 3914

Legend	
WS 3000	—■—
Ground	—●—
Levee	—○—
Bank Sta	—□—

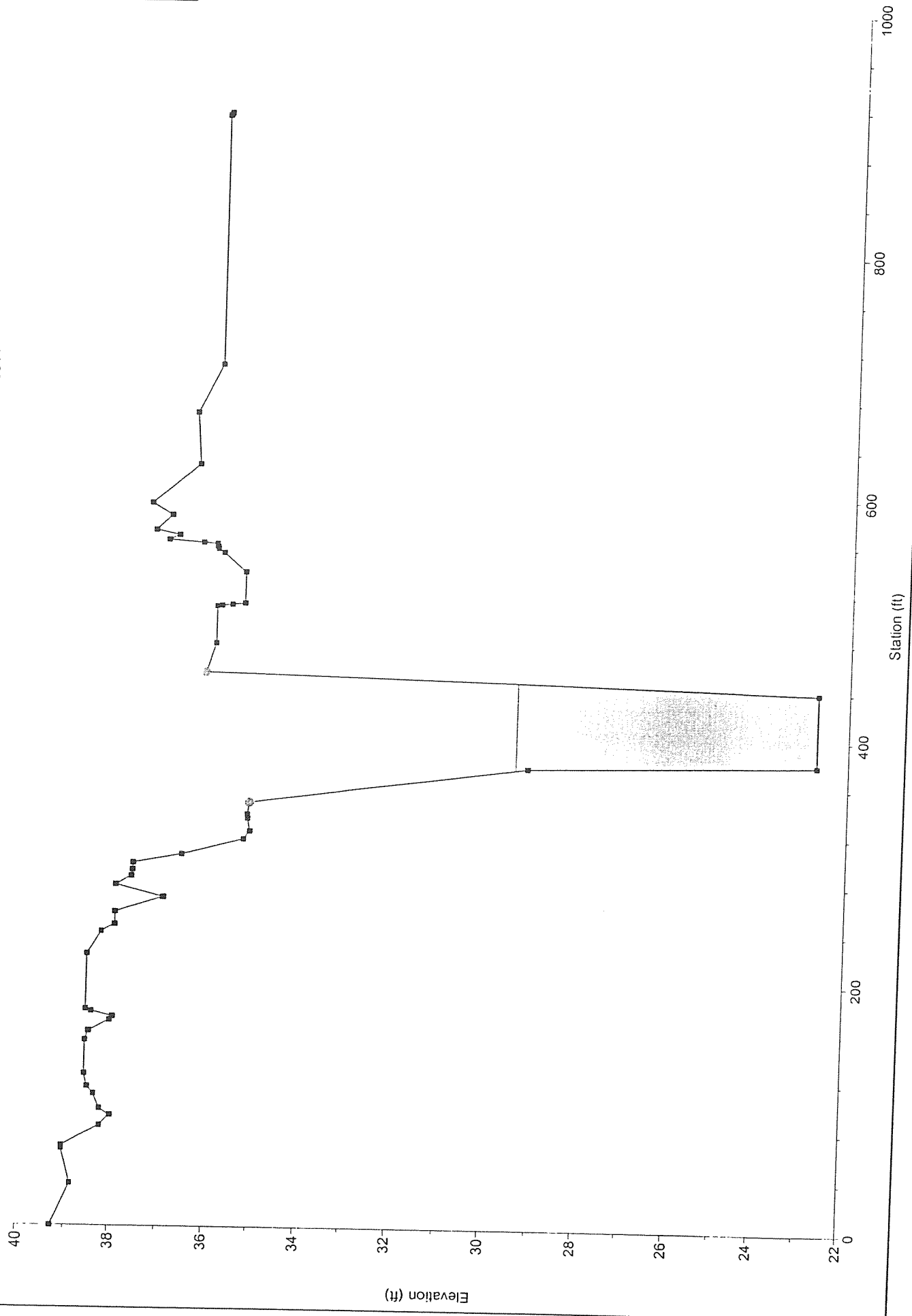

Sycamore Creek Plan: MASTER PLAN CAPACITY RUN 10/29/2003  
RS = 3920 BR CARPINTERIA BRIDGE (N)

Legend	
WS 3000	—
Ground	—■—
Levee	—●—
Bank Sta	○

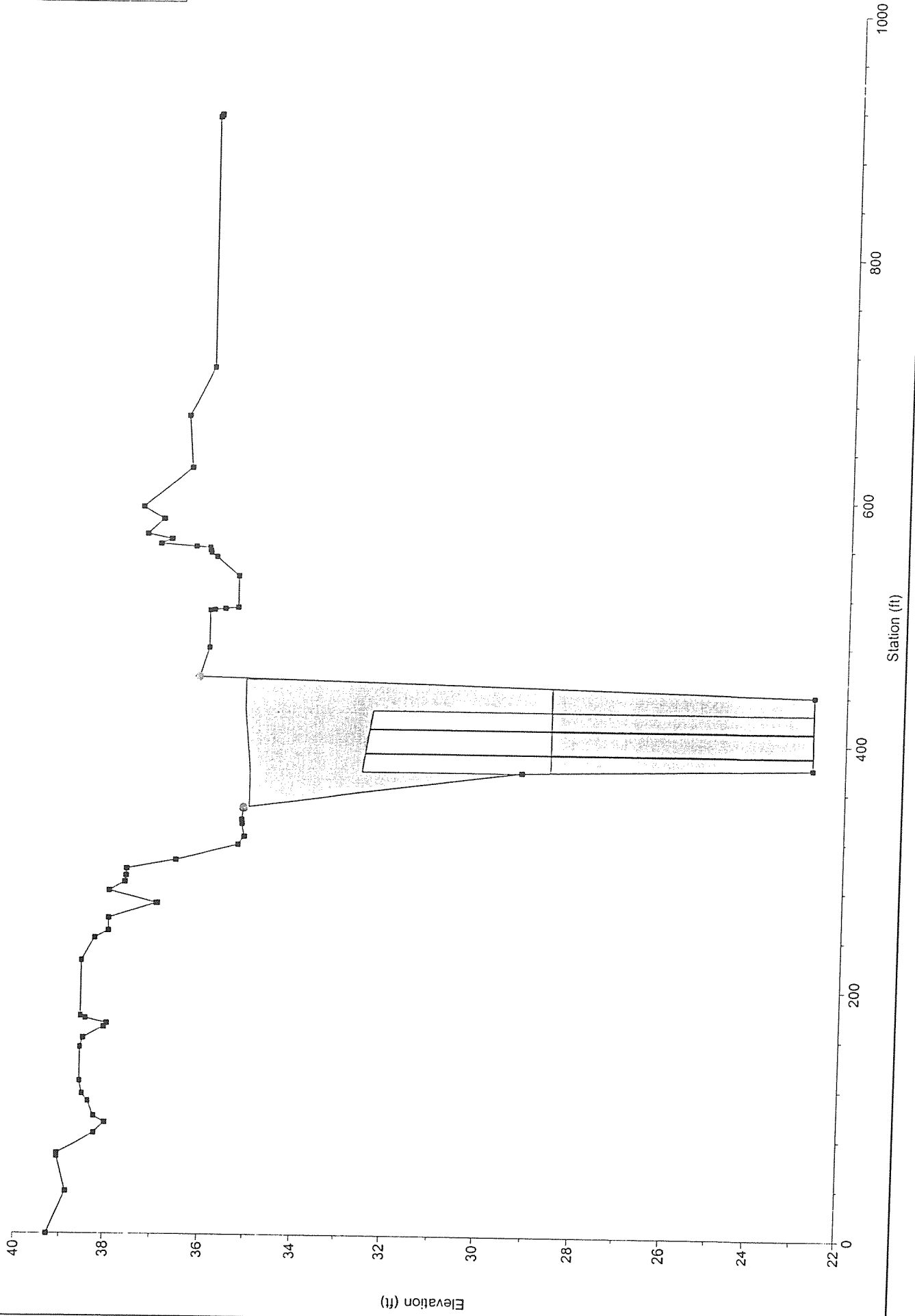

Sycamore Creek Plan: MASTER PLAN CAPACITY RUN 10/29/2003  
 RS = 3920 BR CARPINTERIA BRIDGE (N)

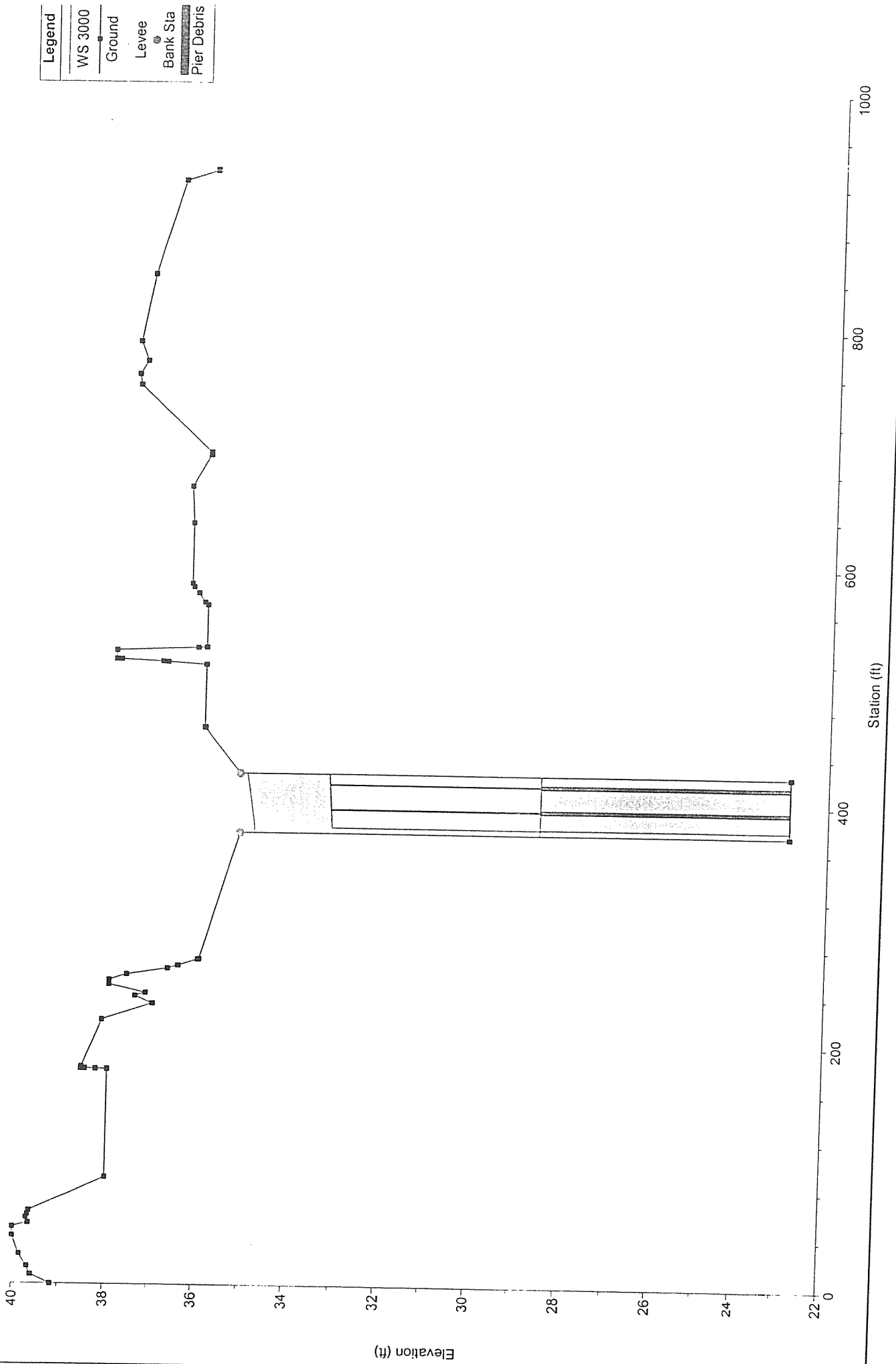

Legend  
 WS 3000  
 Ground  
 Levee  
 Bank Sta  
 Pier Debris



Sycamore Creek Plan: MASTER PLAN CAPACITY RUN 10/29/2003  
 RS = 3953.405 CARPINTERIA BRIDGE - UPSTREAM SIDE - RS 3953

Legend	
WS 3000	Ground
Levee	Bank Sta

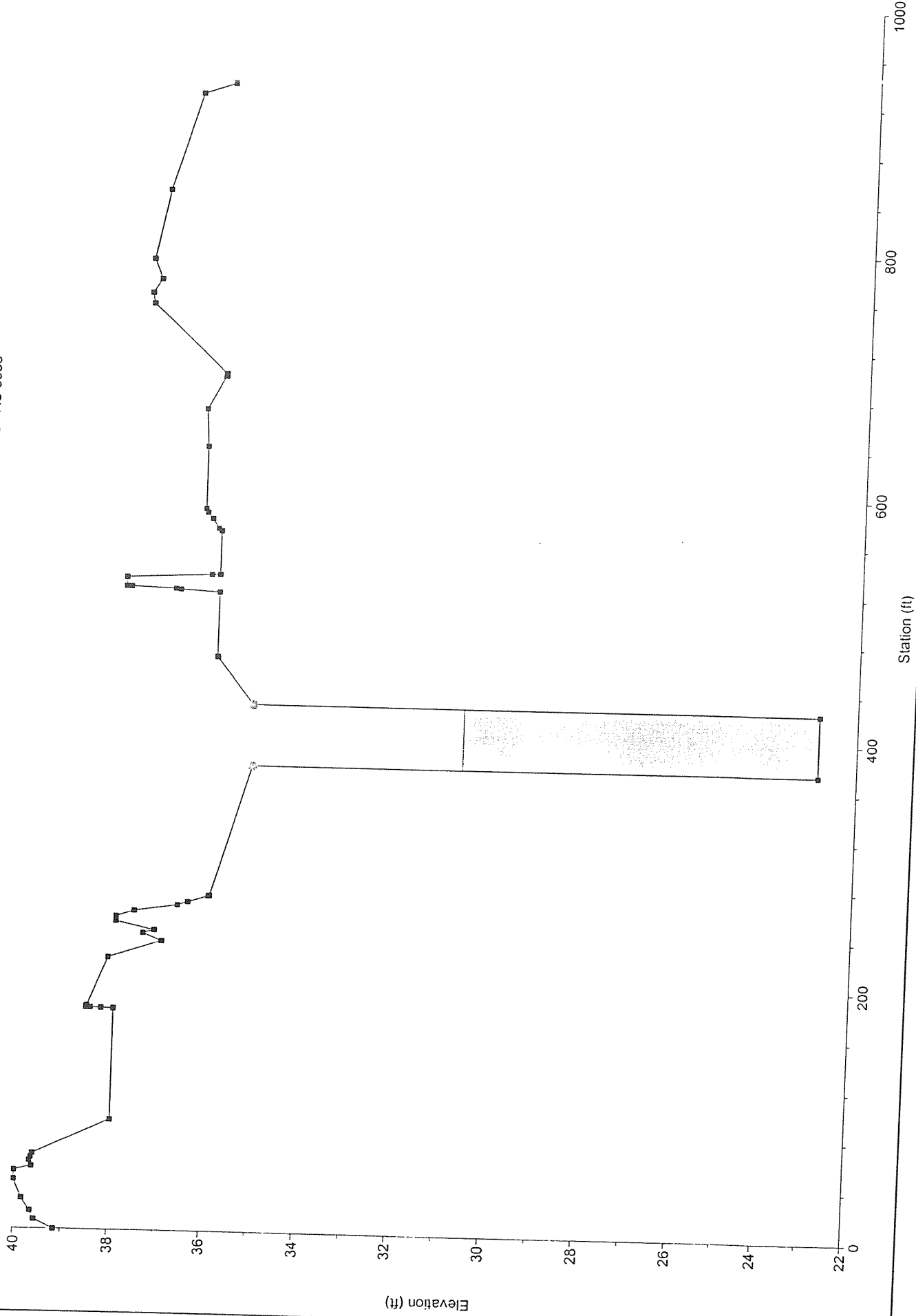

Sycamore Creek Plan: MASTER PLAN CAPACITY RUN 10/29/2003  
RS = 4018.188 BETWEEN CARPINTERIA AND QUINIENTOS #1 - RS 4018

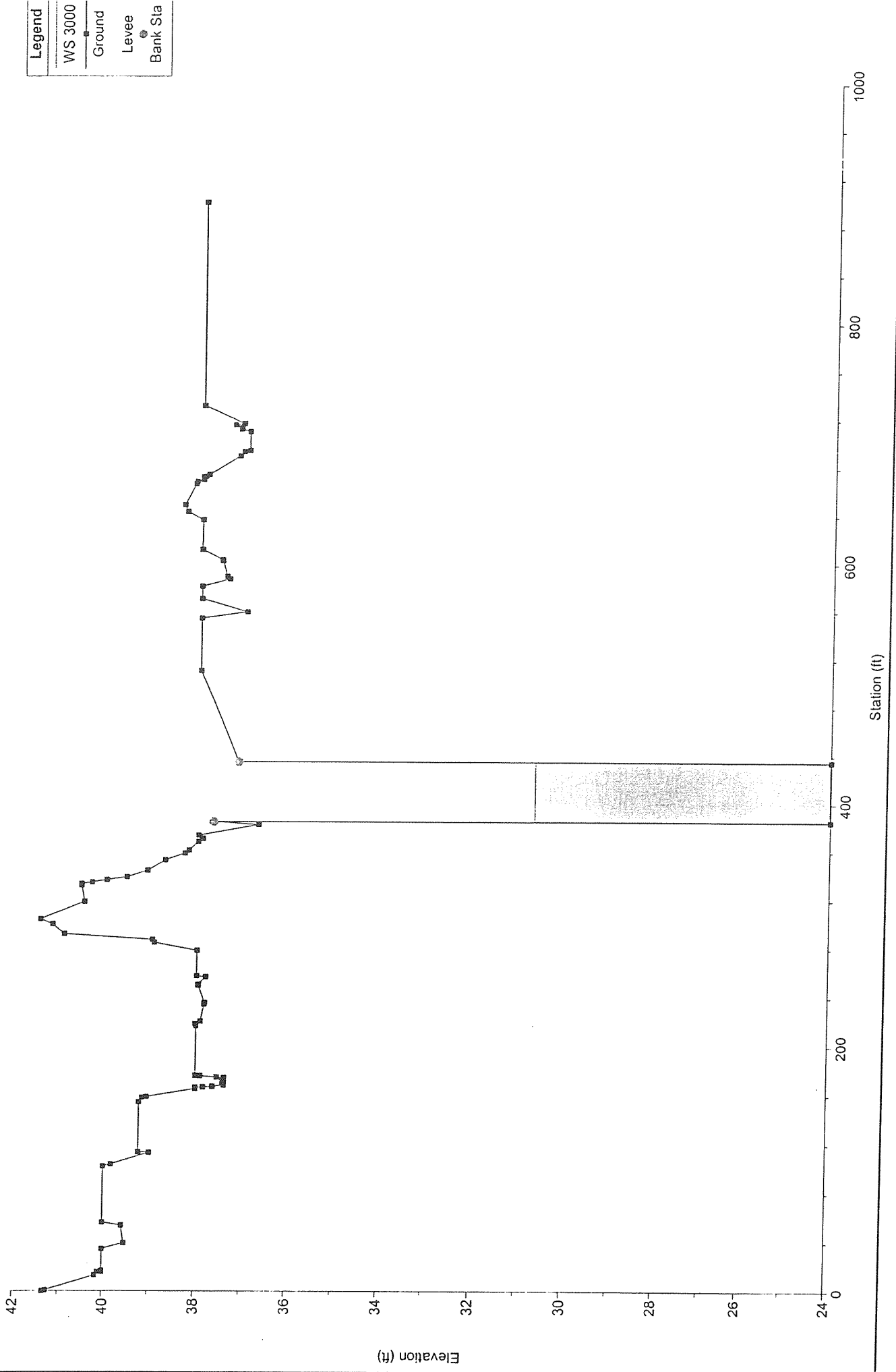

Legend	
WS 3000	—
Ground	—■—
Levee	- - -■- - -
Bank Sta	○

Sycamore Creek Plan: MASTER PLAN CAPACITY RUN 10/29/2003  
 RS = 4322.648 BETWEEN CARPINTERIA AND QUINIENTOS #2 - RS 4322

Legend	
WS 3000	—
Ground	—●—
Levee	—
Bank Sta	●

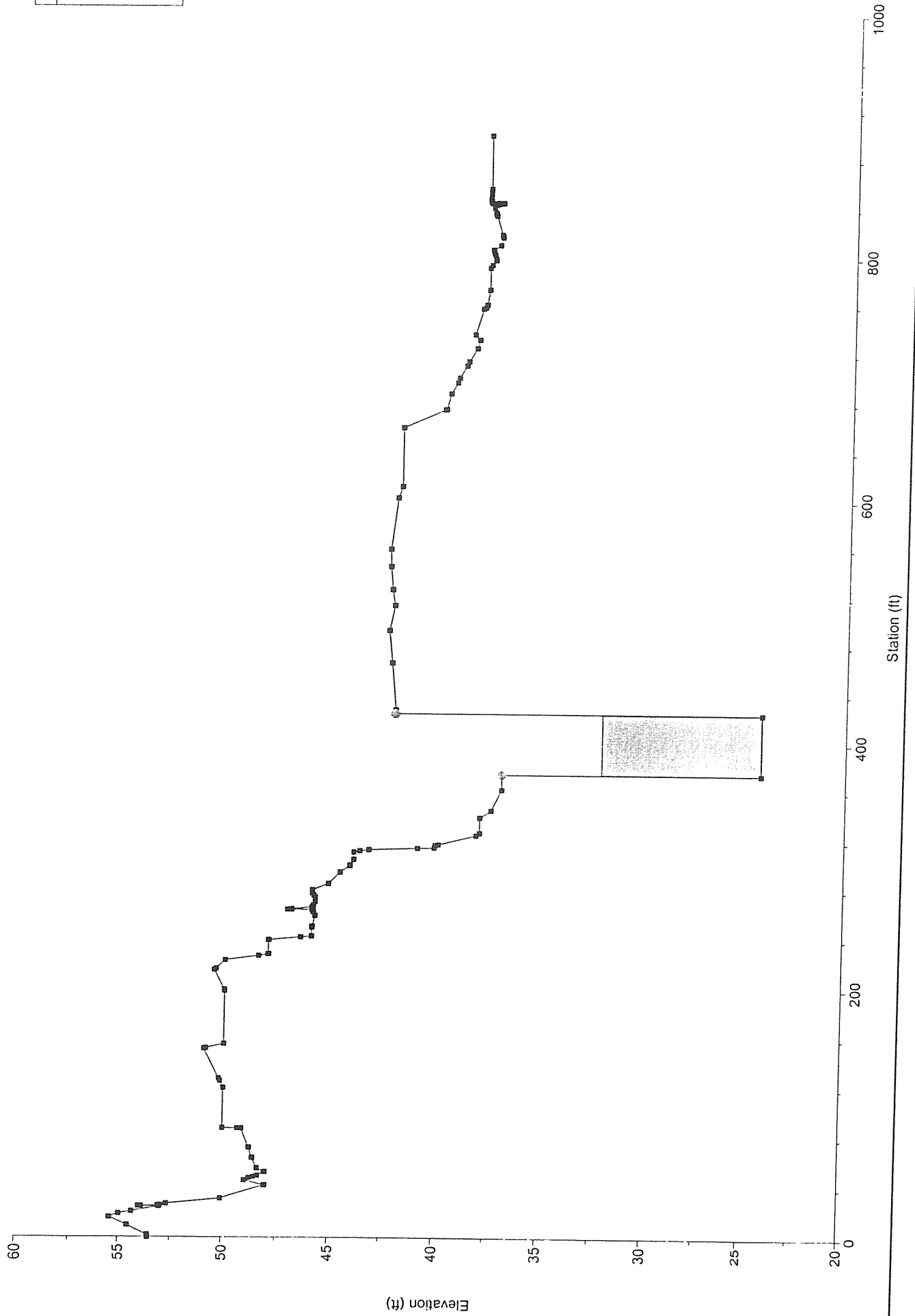

Sycamore Creek Plan: MASTER PLAN CAPACITY RUN 10/29/2003  
RS = 4440.698 QUINIENTOS BRIDGE- DOWNSTREAM SIDE - RS 4440

Legend	
WS 3000	—
Ground	—■—
Levee	—○—
Bank Sta	—●—

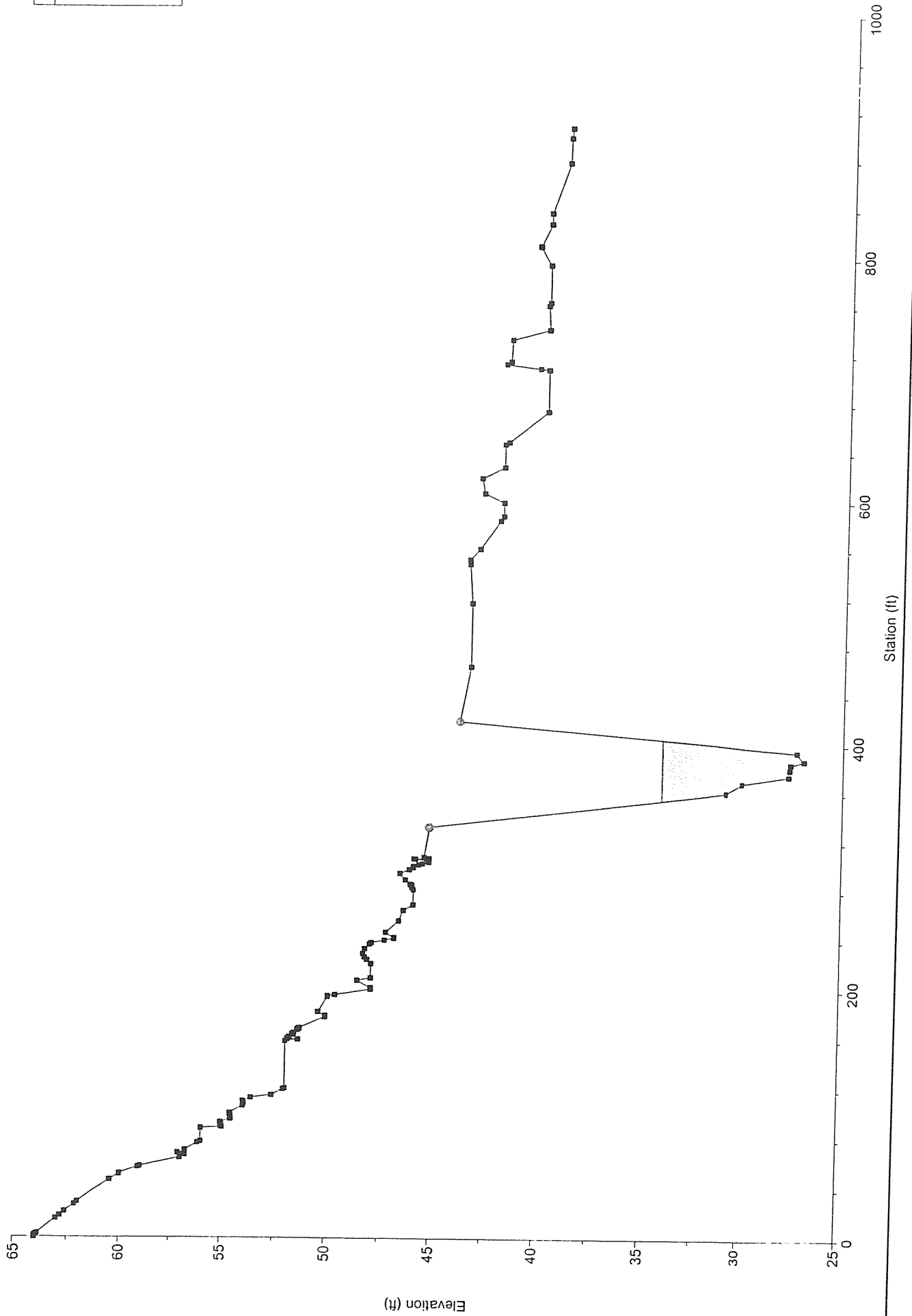

Sycamore Creek Plan: MASTER PLAN CAPACITY RUN 10/29/2003  
RS = 4451 BR QUINIENTOS BRIDGE (Q)

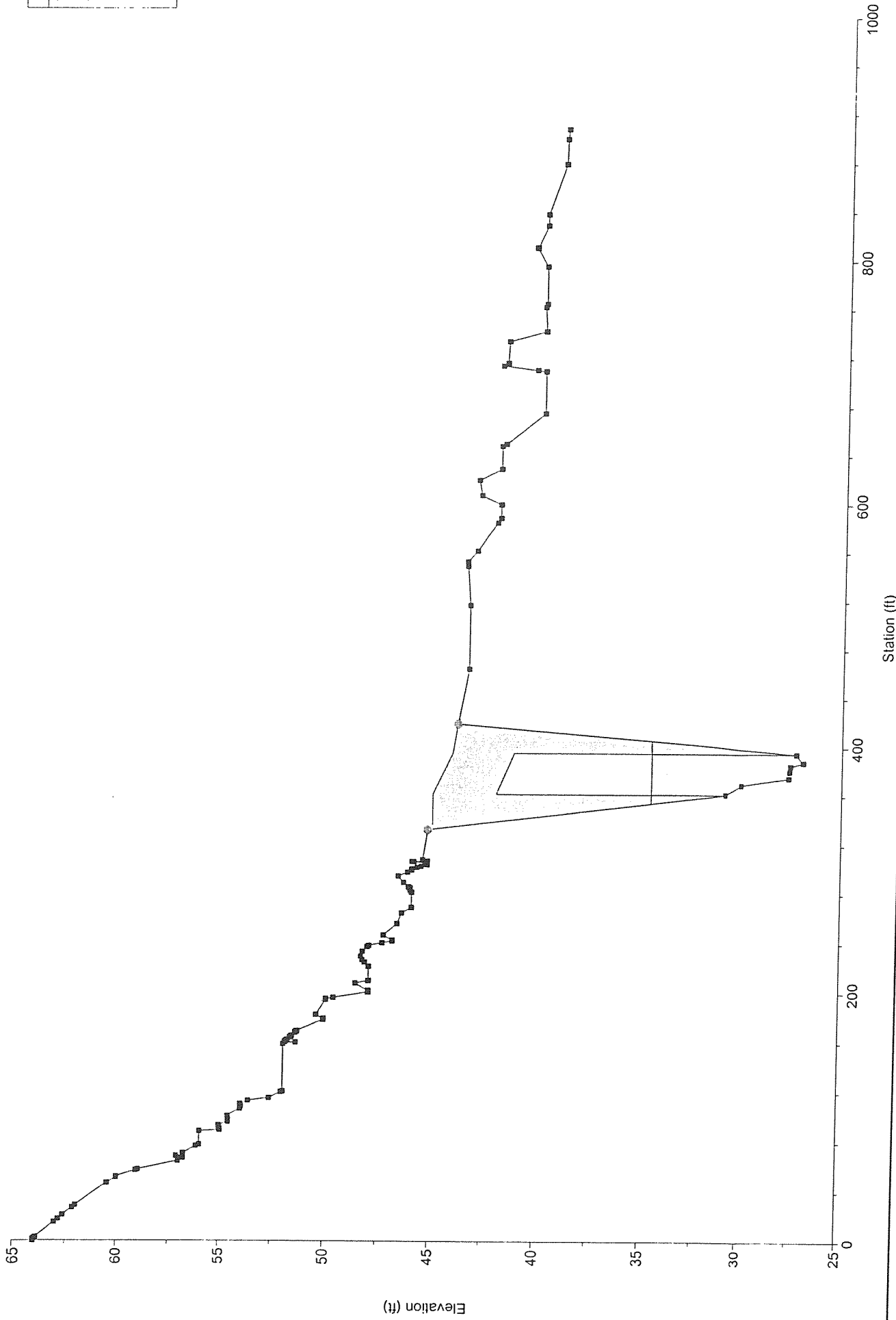

Legend	
WS 3000	(dashed line)
Ground	(solid line with square markers)
Levee	(dotted line)
Bank Sta	(line with circle markers)

Sycamore Creek Plan: MASTER PLAN CAPACITY RUN 10/29/2003  
RS = 4451 BR QUINIENTOS BRIDGE (Q)

Legend	
WS 300C	Ground
Levee	Bank Sta

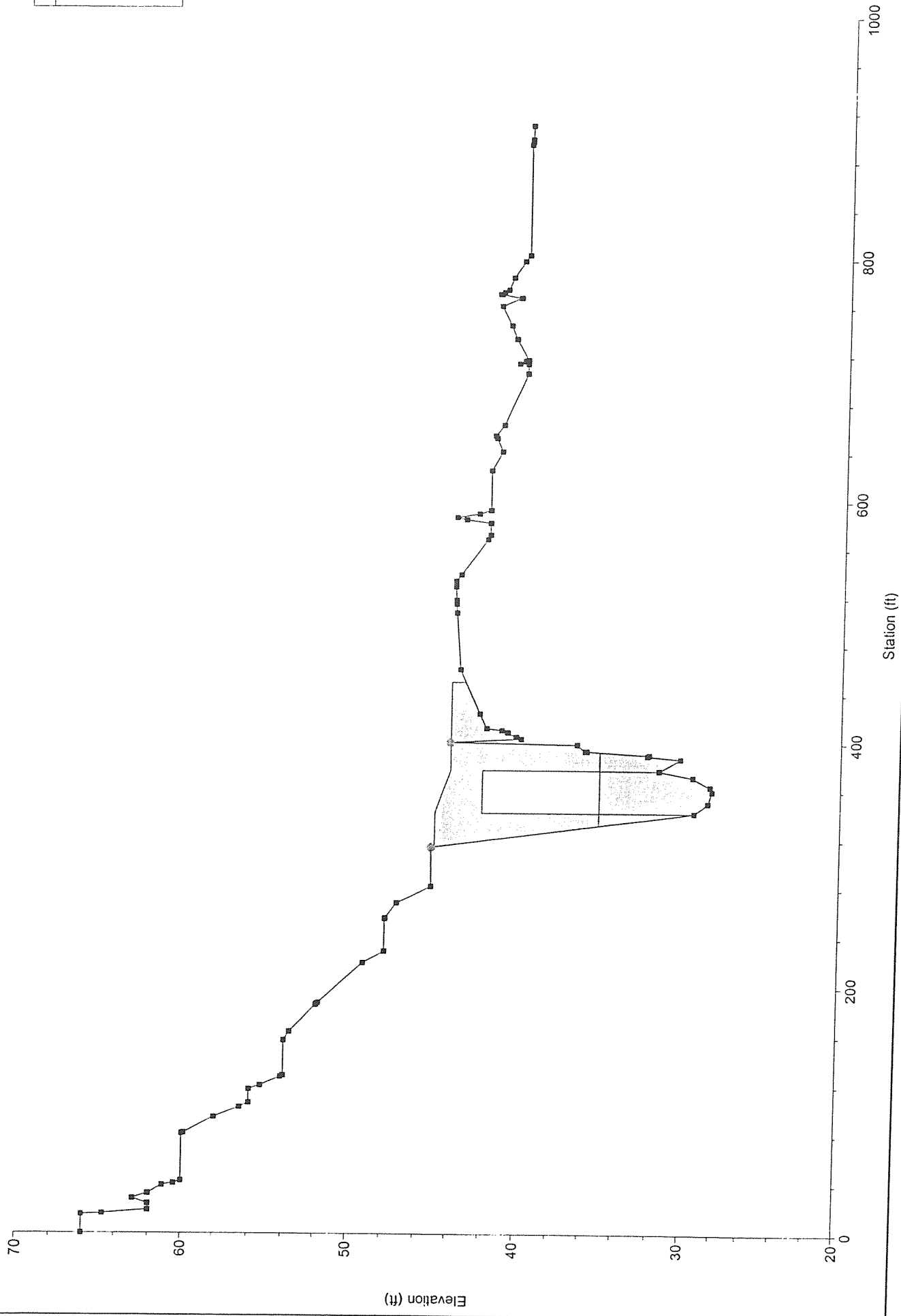

Sycamore Creek Plan: MASTER PLAN CAPACITY RUN 10/29/2003  
RS = 4484.828 QUINIENTOS BRIDGE - UPSTREAM SIDE - RS 4484

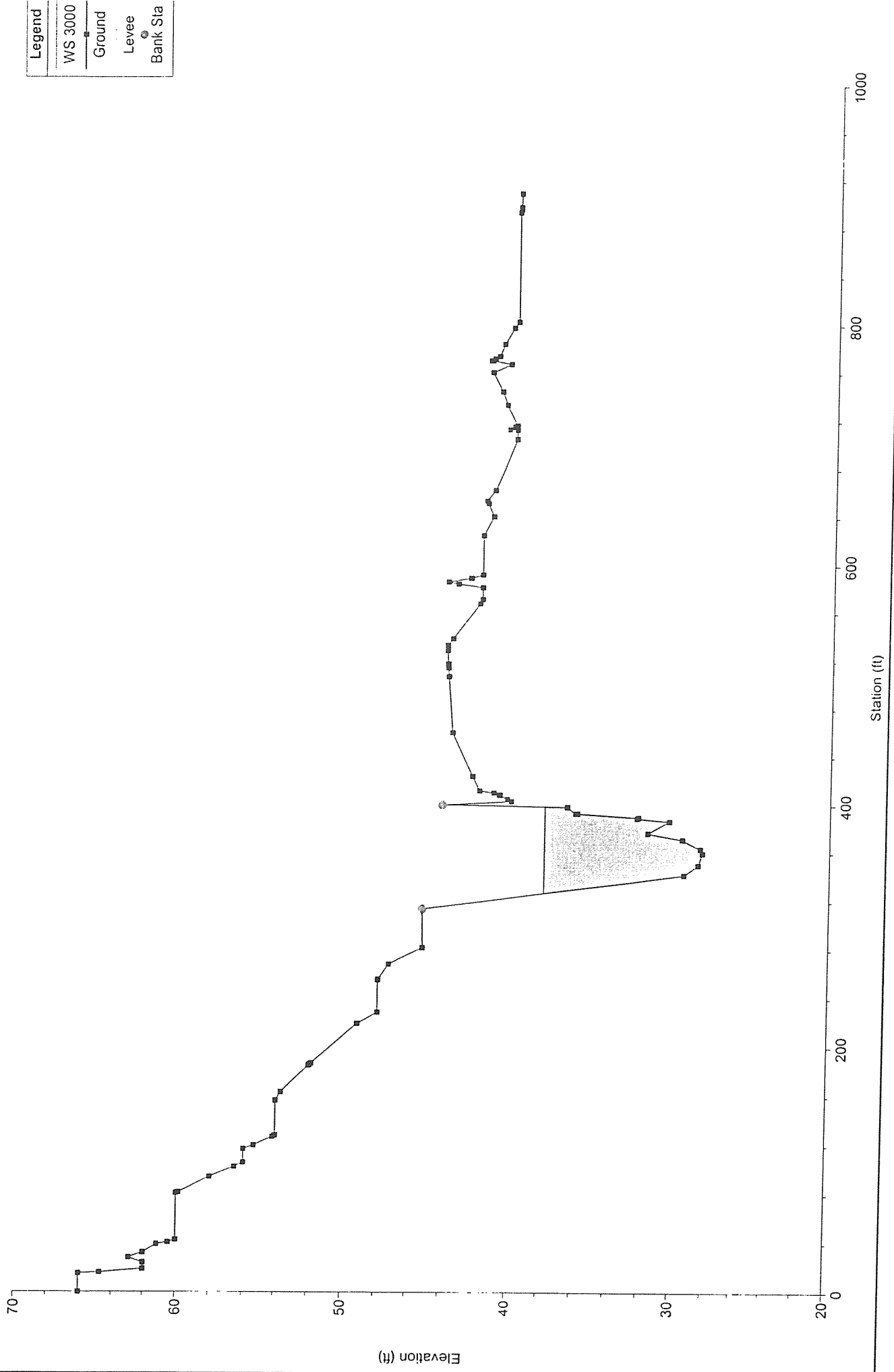

Legend	
WS 3000	---
Ground	—■—
Levee	·····
Bank Sta	○

Sycamore Creek Plan: MASTER PLAN CAPACITY RUN 10/29/2003  
 RS = 4574.630 BETWEEN QUINIENTOS AND MASON ST #1 - RS 4574

Legend	
WS 3000	■
Ground	○
Levee	▨
Bank Sta	●

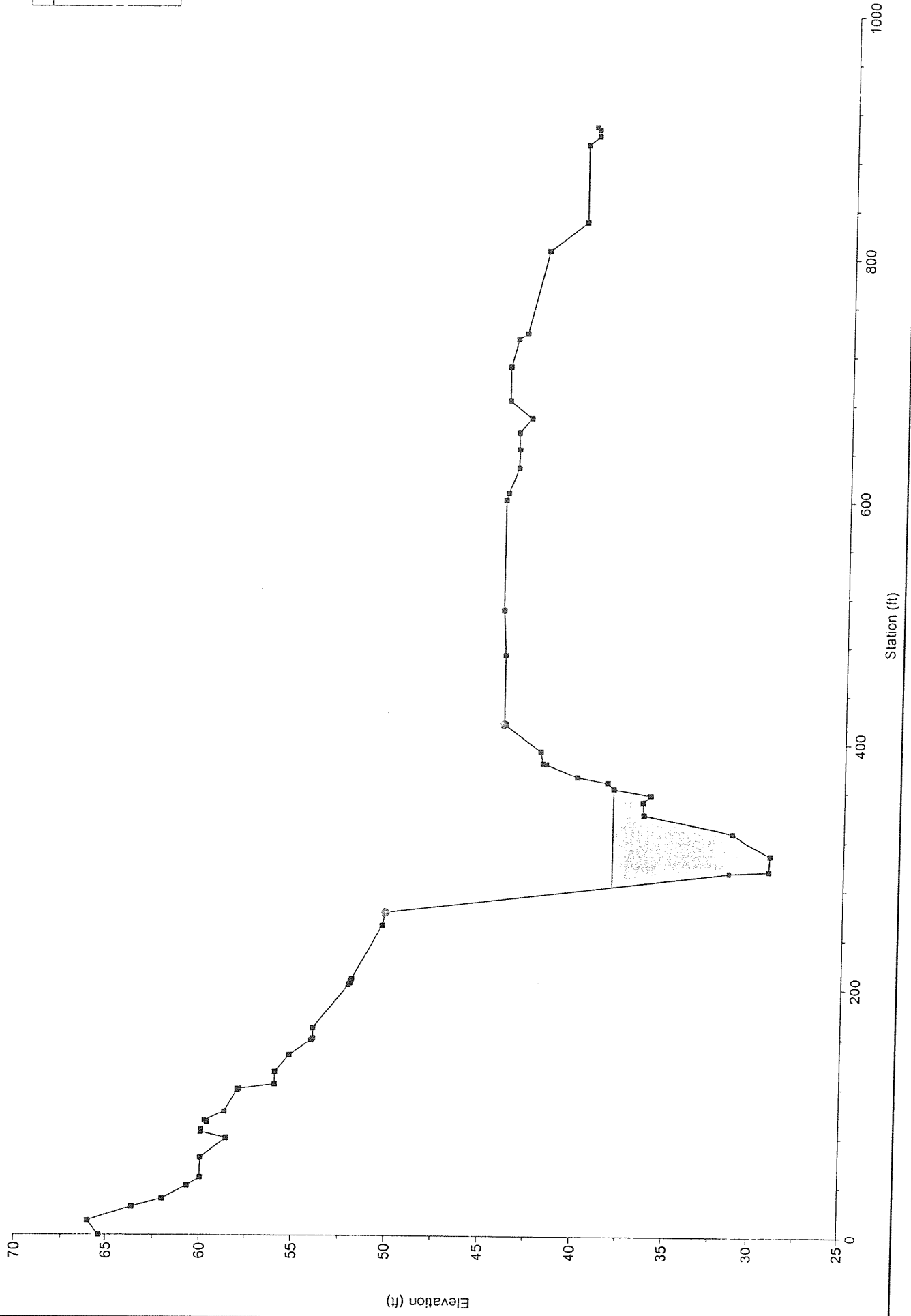



Sycamore Creek Plan: MASTER PLAN CAPACITY RUN 10/29/2003  
 RS = 5021.315 BETWEEN QUINIENTOS AND MASON ST #2 - RS 5021

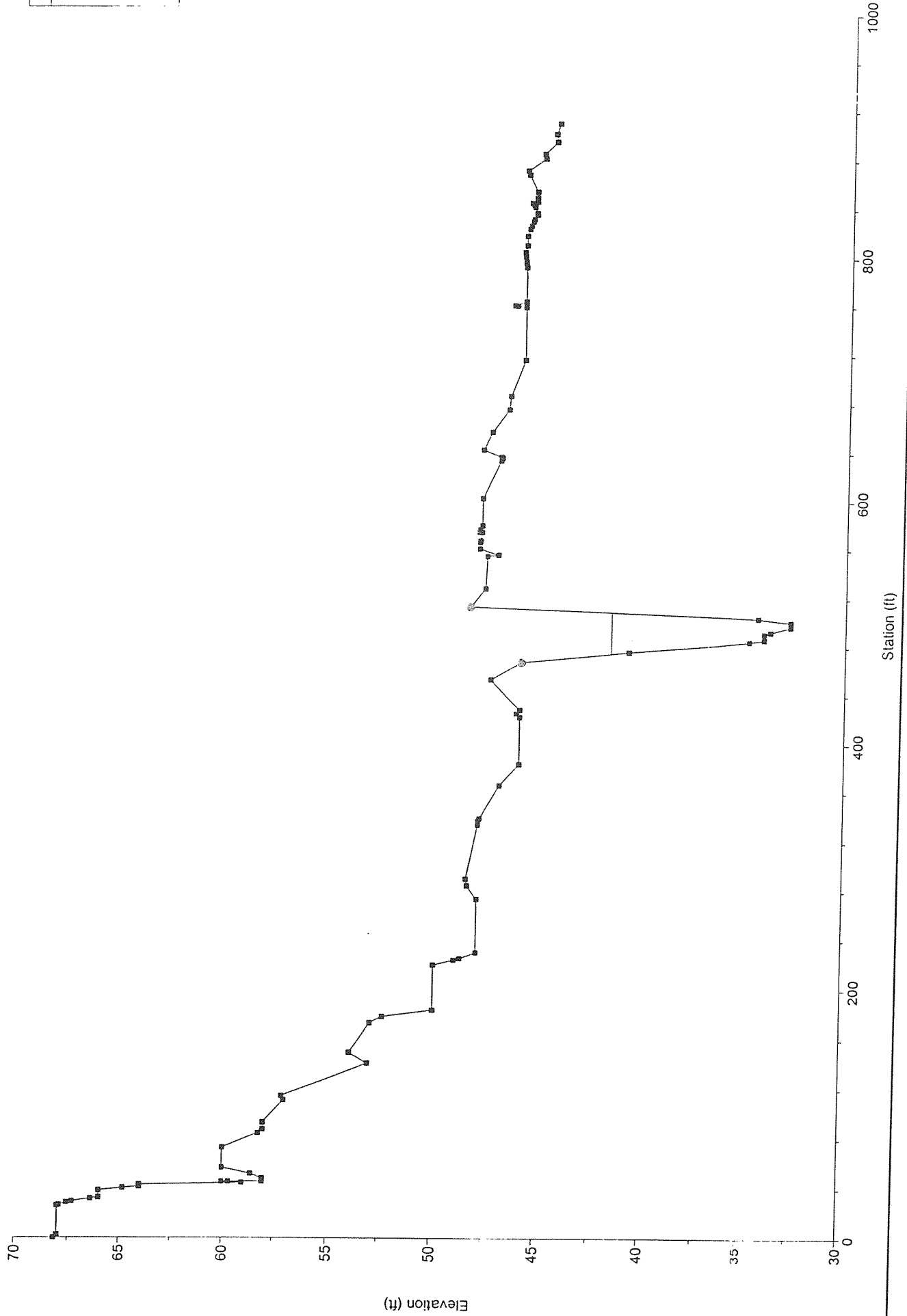

Sycamore Creek Plan: MASTER PLAN CAPACITY RUN 10/29/2003  
RS = 5112.741 MASON ST BRIDGE - DOWNSTREAM SIDE - RS 5112

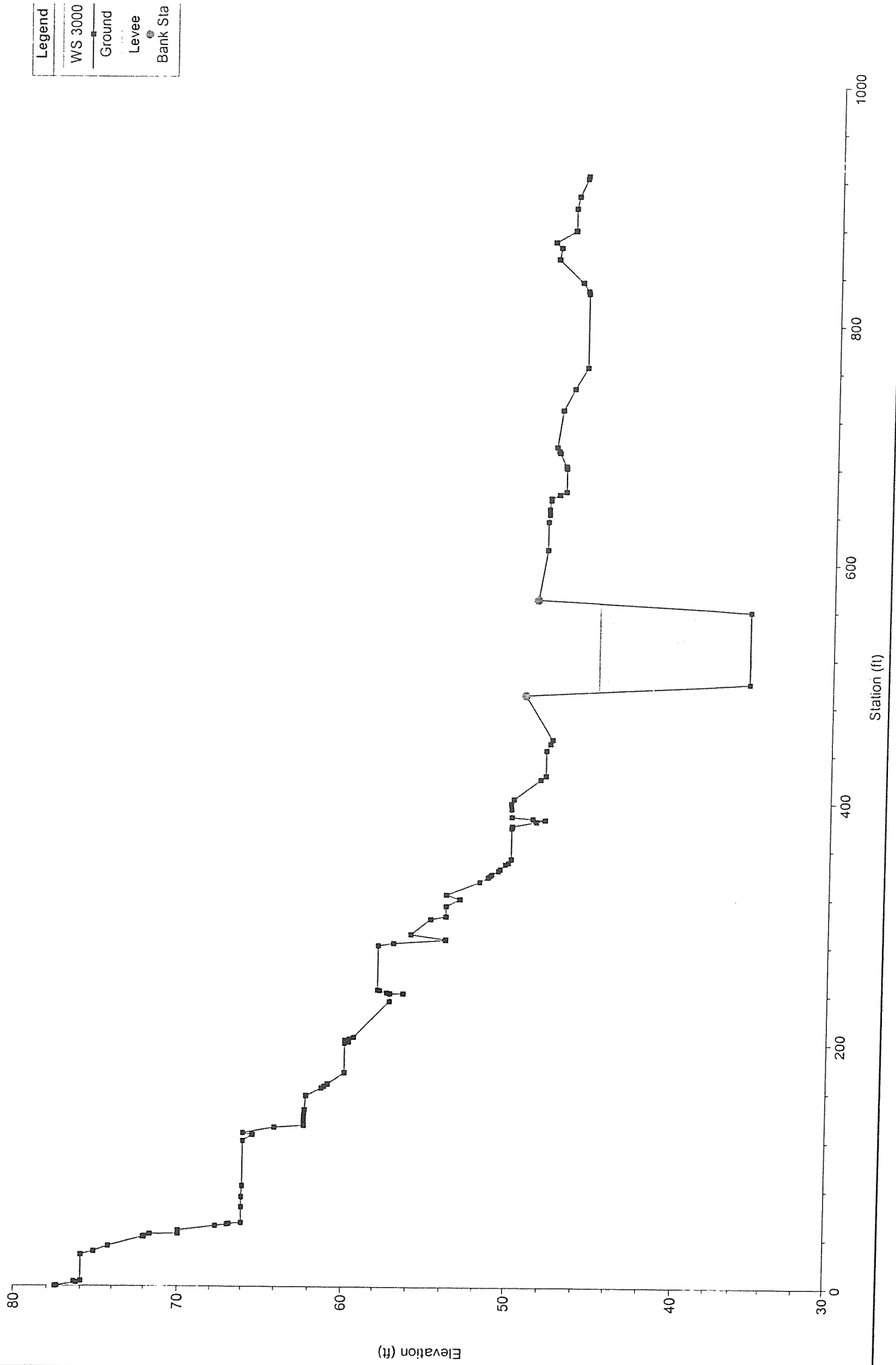

Legend  
WS 3000  
Ground  
Levee  
Bank Sta

Sycamore Creek Plan: MASTER PLAN CAPACITY RUN 10/29/2003  
RS = 5123 BR MASON ST BRIDGE (L)

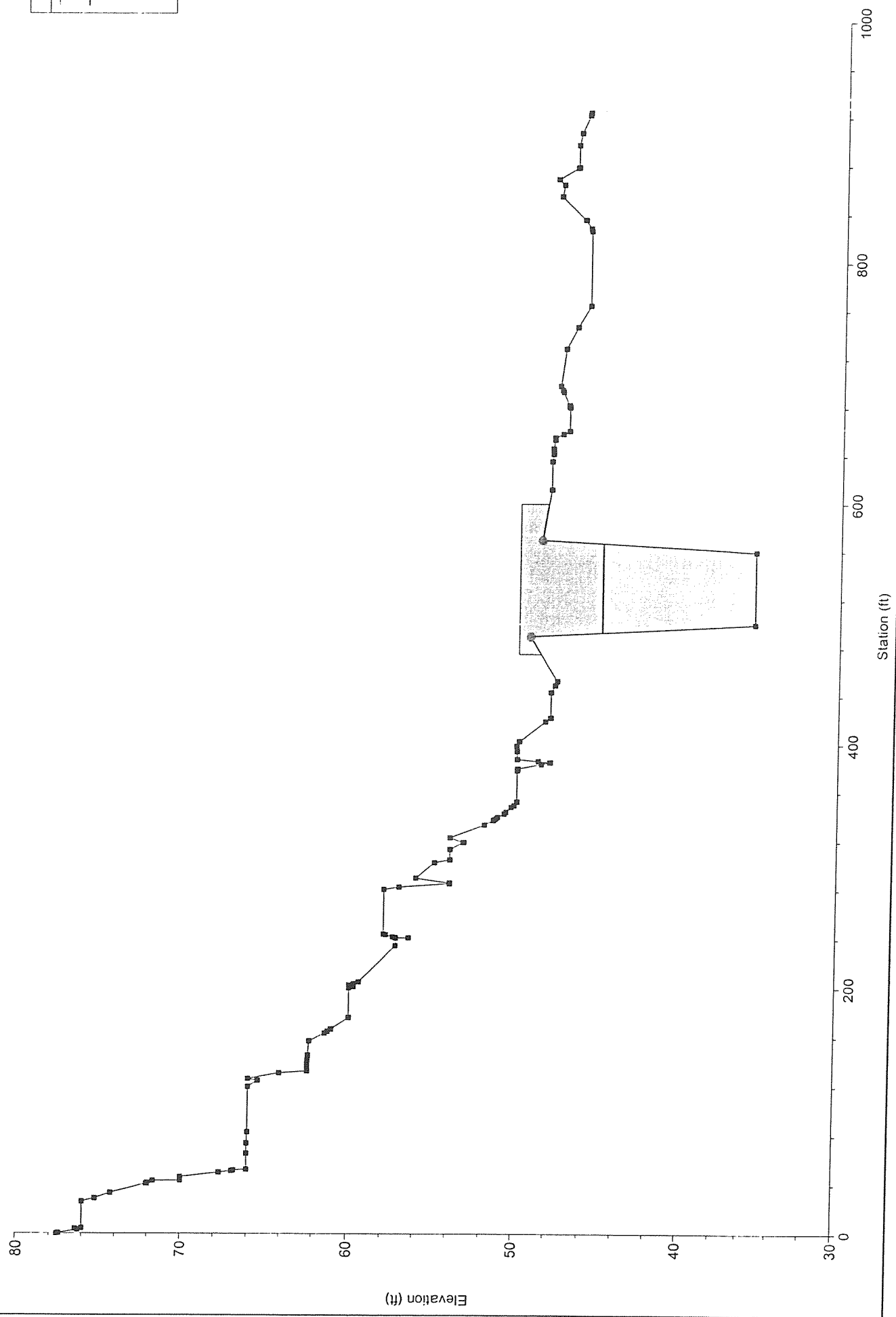

Legend	
WS 3000	—■—
Ground	- - -
Levee	—●—
Bank Sta	—▲—

Sycamore Creek Plan: MASTER PLAN CAPACITY RUN 10/29/2003  
RS = 5123 BR MASON ST BRIDGE (L)

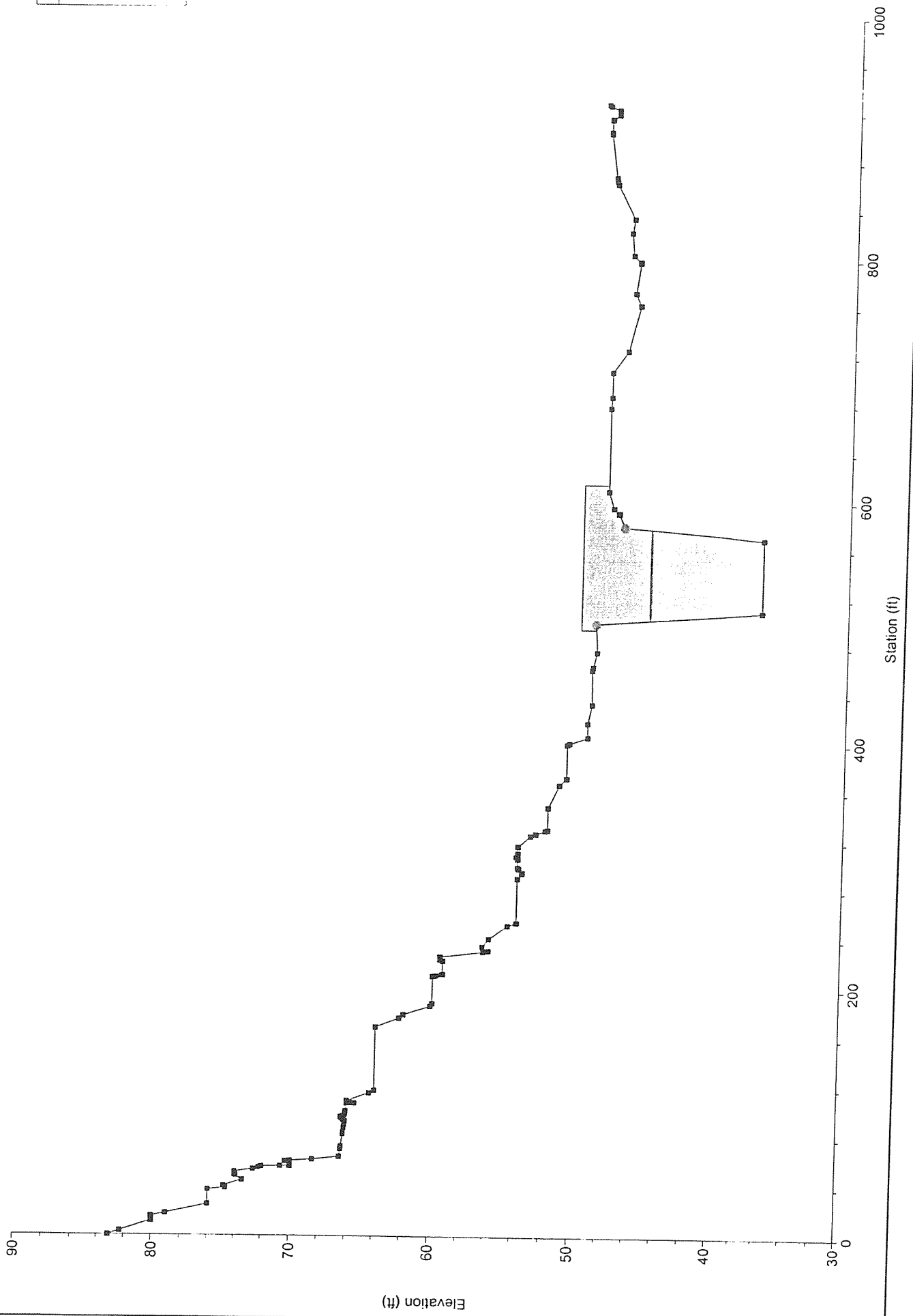

Legend	
WS 3000	—
Ground	—
Levee	—
Bank Sta	—

Sycamore Creek Plan: MASTER PLAN CAPACITY RUN 10/29/2003  
RS = 5150.584 MASON ST BRIDGE - UPSTREAM SIDE - RS 5150

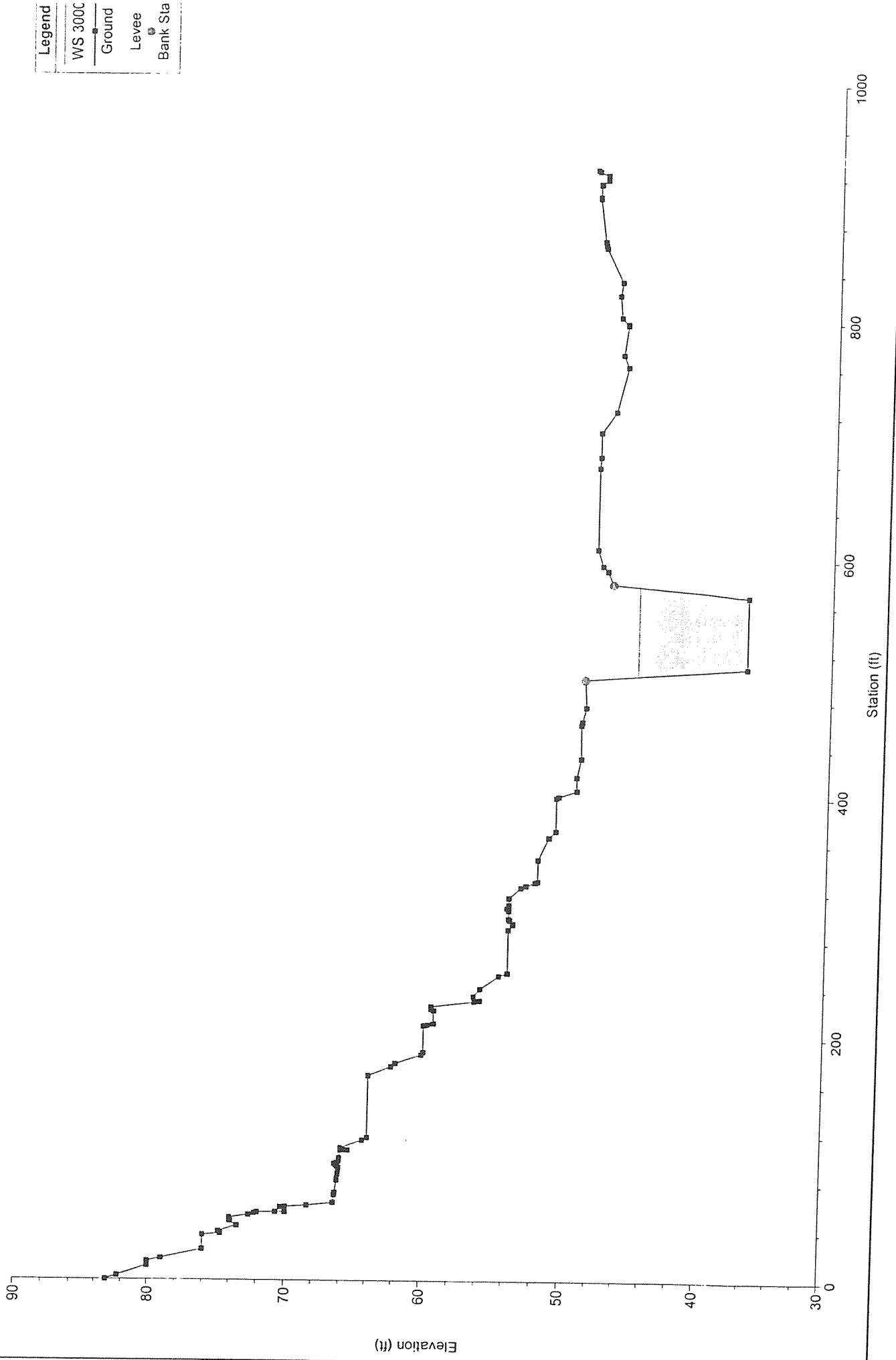

Sycamore Creek Plan: MASTER PLAN CAPACITY RUN 10/29/2003  
 RS = 5300.376 BETWEEN MASON AND YANONALI #1 - RS 5300

Legend	
WS 3000	Ground
	Levee
	Bank Site

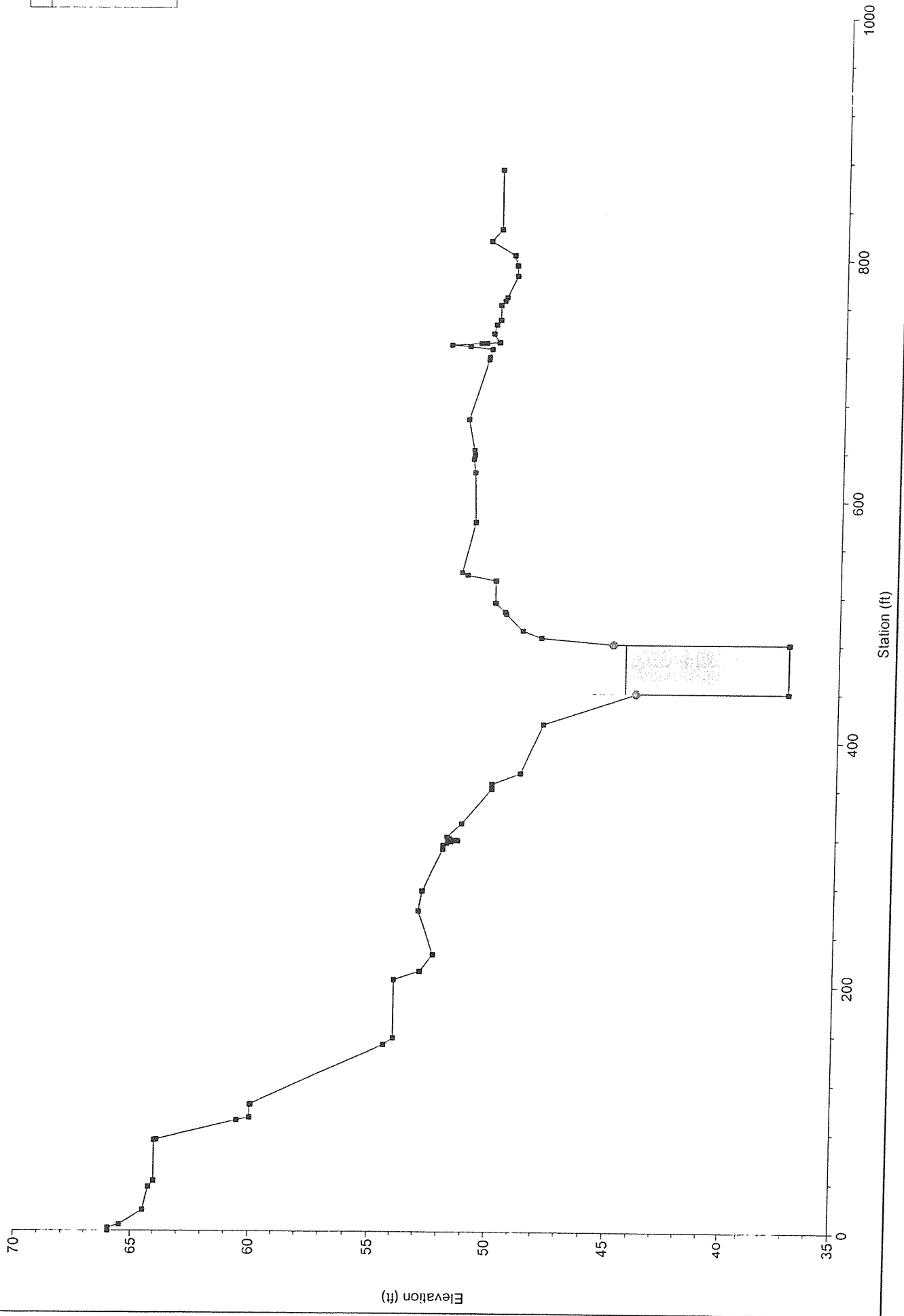

Sycamore Creek Plan: MASTER PLAN CAPACITY RUN 10/29/2003  
RS = 5535.950 BETWEEN MASON AND YANONALI #2 - RS 5535

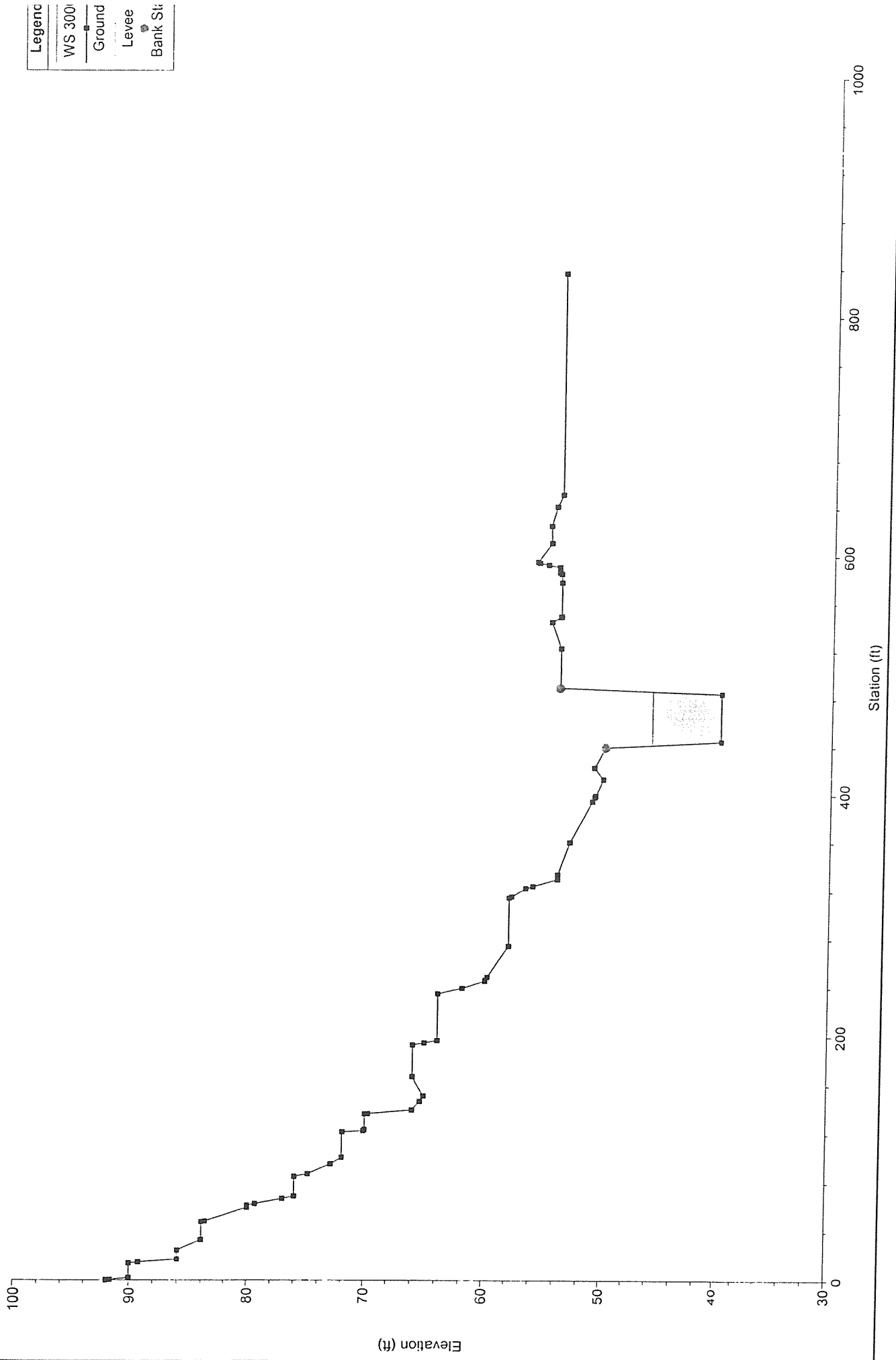

Sycamore Creek Plan: MASTER PLAN CAPACITY RUN 10/29/2003  
RS = 6139.279 YANONALI BRIDGE - DOWNSTREAM SIDE - RS 6139

Legend	
WS 300f	Ground
Levee	Bank St

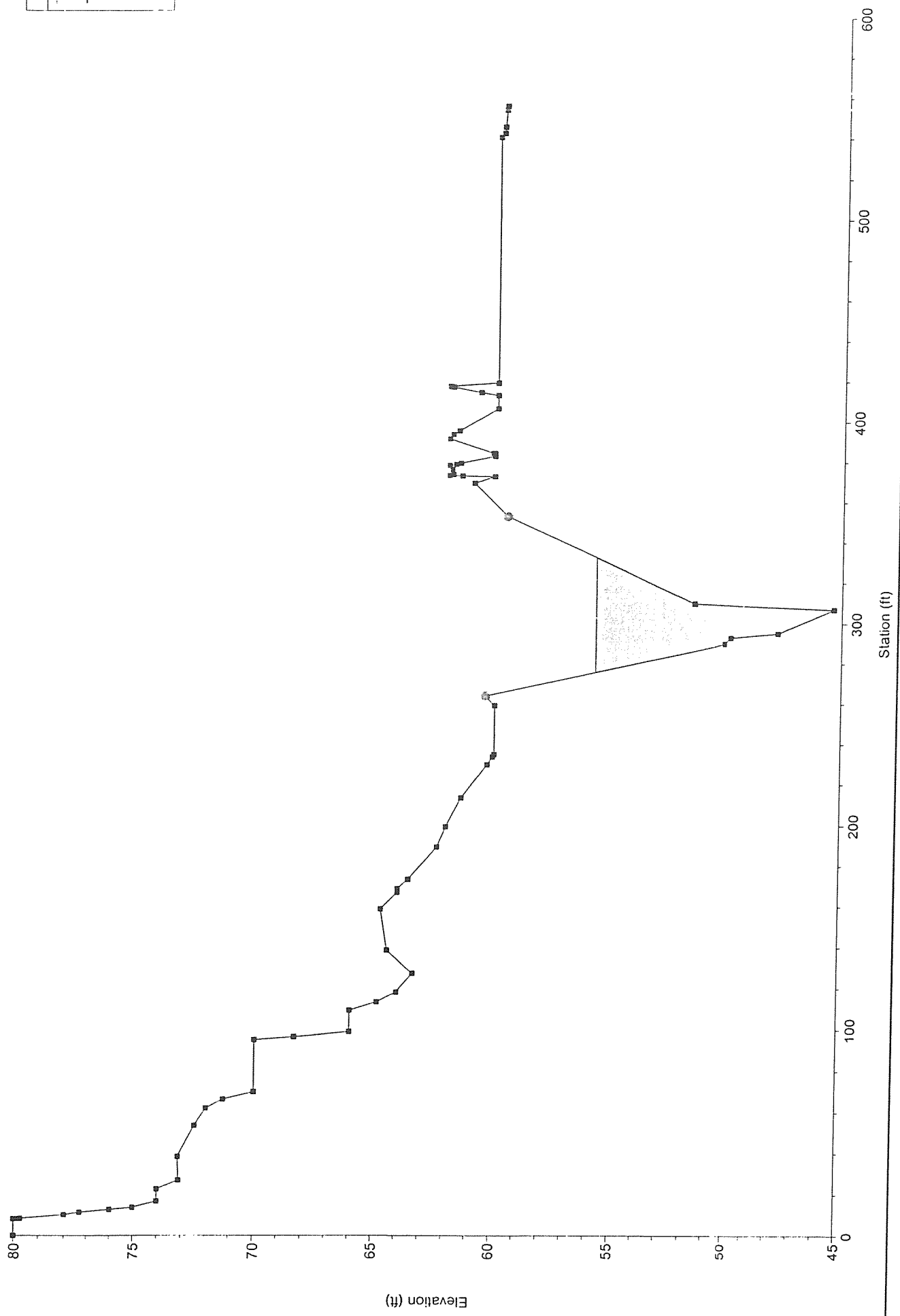



Sycamore Creek Plan: MASTER PLAN CAPACITY RUN 10/29/2003  
 RS = 6141 BR YANONALI BRIDGE

Legend	
WS 300'	—■—
Ground	—
Levee	—
Bank Sta	—

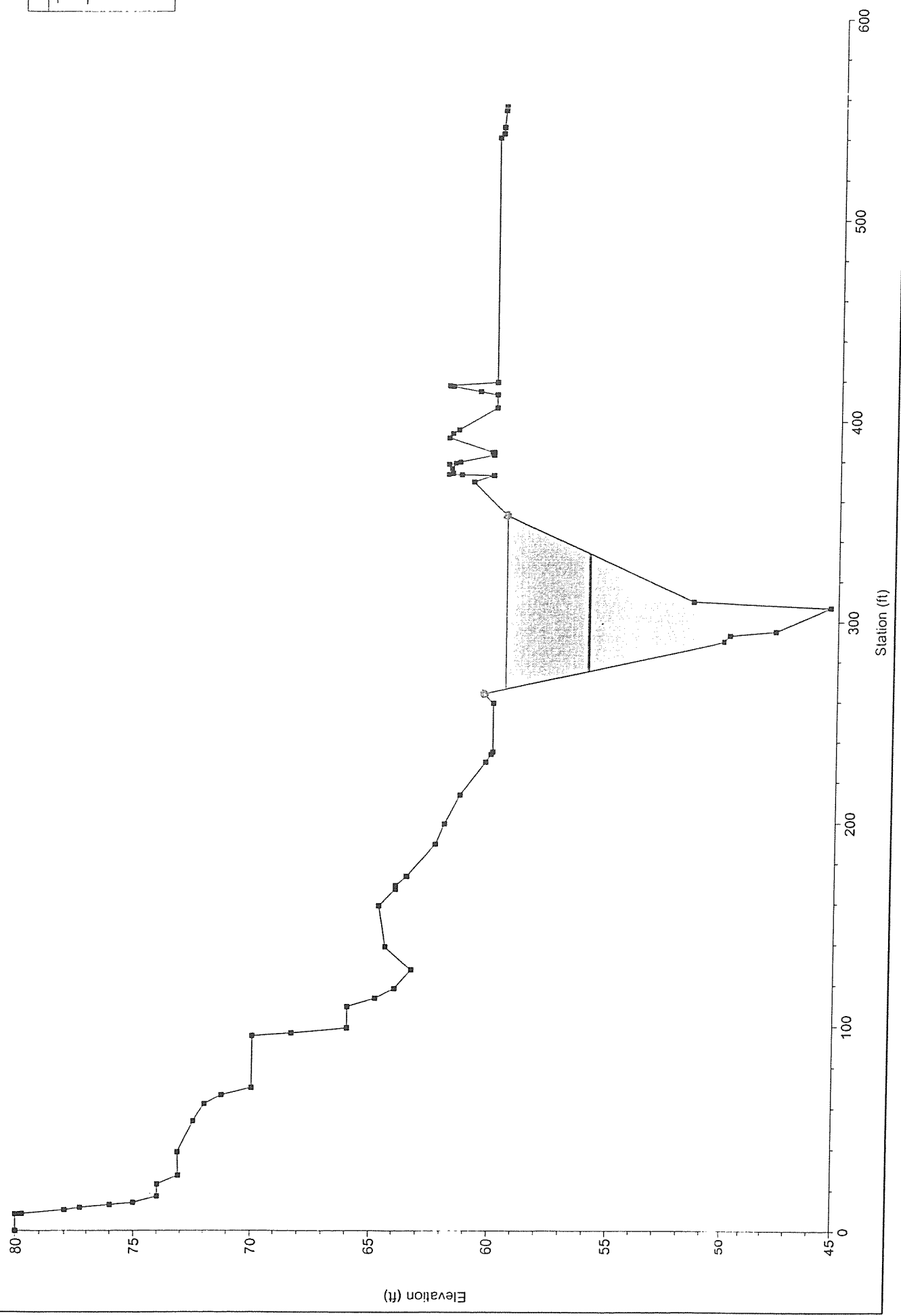

Sycamore Creek Plan: MASTER PLAN CAPACITY RUN 10/29/2003  
 RS = 6141 BR YANONALI BRIDGE

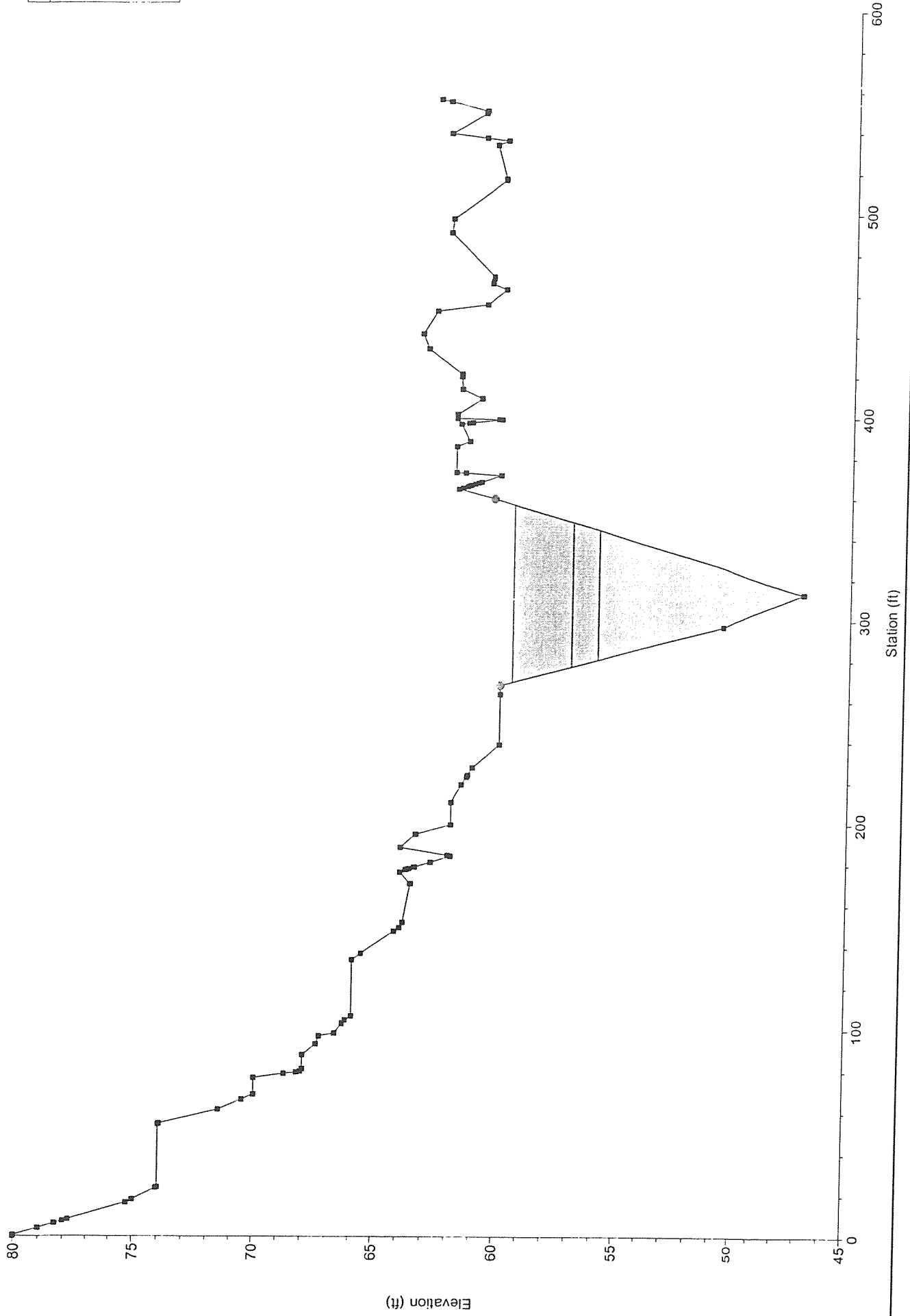

Legend	
WS 30C	(Symbol: Dashed line with square markers)
Ground	(Symbol: Solid line with square markers)
Levee	(Symbol: Solid line with triangle markers)
Bank St	(Symbol: Solid line with circle markers)