

## ACCESSIBILITY REQUIREMENTS

**It is the responsibility of each business operator to provide outdoor dining in full compliance with accessibility requirements of the Americans with Disabilities Act (ADA) and the California Building Code (CBC).** The requirements listed below were developed as part of the overall State Street requirements to assist restaurant operators with meeting these requirements. Nothing contained herein shall replace or diminish any of the requirements under the ADA or CBC. Businesses are encouraged to retain the services of a Certified Access Specialist (CASP) to assist in the design and configuration of their facilities.



**REQUIREMENTS FOR OPERATING A BUSINESS ON THE TEMPORARY STATE STREET PROMENADE**

**Where access to an outdoor business facility is not level, an access ramp must be provided.** Ramps must comply with California Building Code Chapter 11B, summarized as follows:

- ▶ Ramps must be at least 4 feet wide.
- ▶ 8.3% (1:12) maximum running slope (parallel to the direction of travel). If slope is greater than 5%, handrails must be provided on both sides of the ramp.
- ▶ 2% maximum cross slope (perpendicular to the direction of travel).
- ▶ Level landings at the top and bottom of the ramp measuring at least 4 feet by 4 feet.
- ▶ Accessible, unobstructed path of travel from the sidewalk pedestrian path to the ramp.
- ▶ Edge protection is required on each side of the ramp. A curb or barrier that prevents the passage of a 4-inch diameter sphere must be provided along both edges of the ramp. To prevent wheel entrapment, the edge protection must provide a continuous, uninterrupted barrier along the edge of the ramp.
- ▶ Ramp must be firm, stable, and slip-resistant.
- ▶ Ramp must be securely attached so that it does not move or shift during use.
- ▶ Ramp must not have abrupt vertical edges (“lips”) or variations over  $\frac{1}{2}$  inch in height. Edges or changes in height between  $\frac{1}{4}$  and  $\frac{1}{2}$  inch must be beveled to provide a smooth transition.

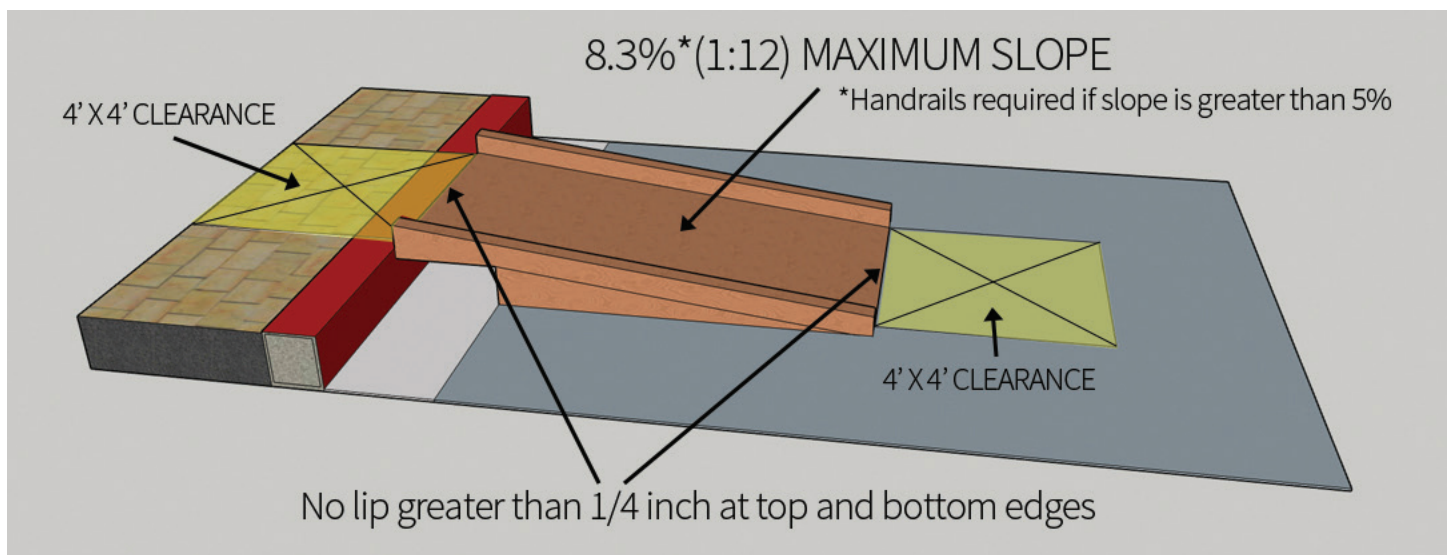

**REQUIREMENTS FOR OPERATING A BUSINESS ON THE TEMPORARY STATE STREET PROMENADE**

**Vertical clearance (distance to any overhead element, including lighting and umbrellas) must be a minimum of 80 inches.** If clearance is less than 80 inches, guards or handrails are required.

For beverage and dining establishments, **at least 5% of the seating spaces and 5% of the standing spaces shall be accessible.** Accessible spaces must meet the following requirements:

- ▶ The table or counter surface must be between 28 and 34 inches high.
- ▶ The space between the floor and the bottom of the table or counter must be at least 27 inches high.
- ▶ Knee clearance must extend at least 19 inches under the table or counter. Knee clearance is measured from the edge of the table or counter to the outside edge of any obstruction under the table or counter, including table legs and bases. Pedestal-style tables are not accessible.
- ▶ Table or counter legs, bases, or supports must be at least 30 inches apart, as measured from the narrowest point.
- ▶ Each seat must have at least 30 inches by 48 inches of clear floor area and must be at least 4 feet from the nearest obstruction.
- ▶ The International Symbol of Accessibility must be displayed at the table(s).
- ▶ An accessible path of travel at least 44 inches wide must be maintained to the accessible table(s).
- ▶ Accessible dining tables and surfaces must be dispersed throughout the space.

